

# High-Side Current-Sense and Dual 1°C Temperature Monitor

## PRODUCT FEATURES

Data Brief

### General Description

The EMC1702 is a combination high-side current sensing device with precision temperature measurement. It measures the voltage developed across an external sense resistor to represent the high-side current of a battery or voltage regulator. It also measures the bus voltage and uses these measured values to present a proportional power calculation. The EMC1702 contains additional bi-directional peak detection circuitry to flag instantaneous current spikes with programmable time duration and magnitude threshold. Finally, the EMC1702 includes an external diode channel for temperature measurement as well as an internal diode for ambient temperature measurements.

The temperature measurement includes advanced features such as Resistance Error Correction (REC), Beta Compensation (to support CPU diodes requiring the BJT/transistor model including 45nm and 65nm processors), and automatic diode type detection.

Both current sensing and temperature monitoring include two tiers of protection: one that can be masked and causes the ALERT pin to be asserted, and the other that cannot be masked and causes the THERM pin to be asserted.

### Applications

- Notebook and Desktop Computers
- Industrial
- Power Management Systems
- Embedded Applications

### Features

- High-side current sensor
  - Bi-directional current measurement
  - Measures bus voltage and indicates power ratio
  - 1% current measurement accuracy
  - Integrated over 82ms to 2.6sec with 11-bit resolution
  - 3V to 24V voltage bus voltage range
- Independent hardware set instantaneous current peak detector
  - Software controls to program time duration and magnitude threshold
- Power supply options
  - Bus or separately powered for low voltage operation
- Wide temperature operating range: -40°C to +85°C
- One external temperature monitor
  - 1°C accuracy ( $20^{\circ}\text{C} < T_{\text{DIODE}} < 110^{\circ}\text{C}$ ) with 0.125°C resolution
  - Ideality factor setting
  - Support for 45nm and 65nm CPU diodes requiring the BJT/transistor model w/ beta compensation
  - Determines external diode type and optimal settings
  - Resistance Error Correction
- Internal temperature monitor
  - $\pm 1^{\circ}\text{C}$  accuracy ( $-5^{\circ}\text{C} < T_{\text{A}} < 85^{\circ}\text{C}$ )
- ALERT and THERM outputs for temperature, voltage, and out-of-current limit reporting
- SMBus 2.0 interface
  - Pin-selectable SMBus Address
  - Block Read and Write
- Available in a 12-pin 4mm x 4mm QFN RoHS Compliant Package

### Block Diagram

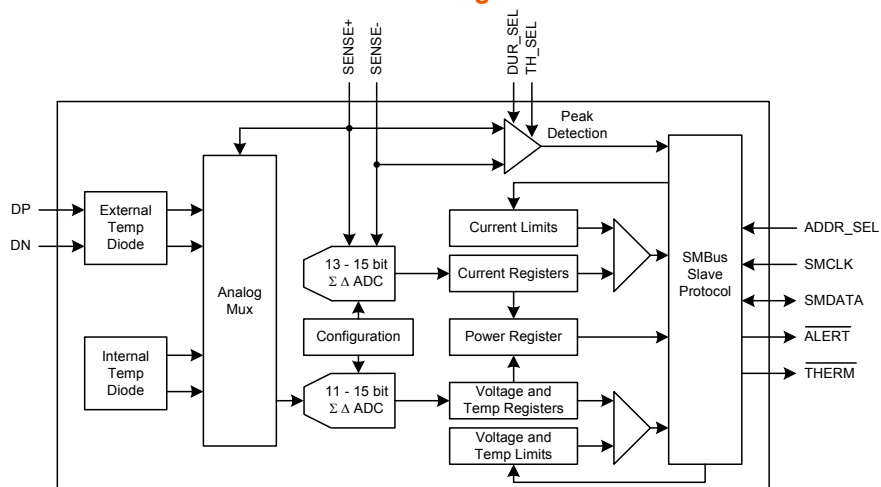

**Order Number(s):**

<b>ORDERING NUMBER</b>	<b>PACKAGE</b>	<b>FEATURES</b>
EMC1702-1-KP-TR	12-pin 4mm x 4mm QFN (Lead-free ROHS compliant)	External Diode, current sensor, hardware set peak detector

**REEL SIZE IS 4,000 PIECES**

**This product meets the halogen maximum concentration values per IEC61249-2-21**

**For RoHS compliance and environmental information, please visit [www.smsc.com/rohs](http://www.smsc.com/rohs)**



80 ARKAY DRIVE, HAUPPAUGE, NY 11788 (631) 435-6000, FAX (631) 273-3123

Copyright © 2010 SMSC or its subsidiaries. All rights reserved.

Circuit diagrams and other information relating to SMSC products are included as a means of illustrating typical applications. Consequently, complete information sufficient for construction purposes is not necessarily given. Although the information has been checked and is believed to be accurate, no responsibility is assumed for inaccuracies. SMSC reserves the right to make changes to specifications and product descriptions at any time without notice. Contact your local SMSC sales office to obtain the latest specifications before placing your product order. The provision of this information does not convey to the purchaser of the described semiconductor devices any licenses under any patent rights or other intellectual property rights of SMSC or others. All sales are expressly conditional on your agreement to the terms and conditions of the most recently dated version of SMSC's standard Terms of Sale Agreement dated before the date of your order (the "Terms of Sale Agreement"). The product may contain design defects or errors known as anomalies which may cause the product's functions to deviate from published specifications. Anomaly sheets are available upon request. SMSC products are not designed, intended, authorized or warranted for use in any life support or other application where product failure could cause or contribute to personal injury or severe property damage. Any and all such uses without prior written approval of an Officer of SMSC and further testing and/or modification will be fully at the risk of the customer. Copies of this document or other SMSC literature, as well as the Terms of Sale Agreement, may be obtained by visiting SMSC's website at <http://www.smsc.com>. SMSC is a registered trademark of Standard Microsystems Corporation ("SMSC"). Product names and company names are the trademarks of their respective holders.

**SMSC DISCLAIMS AND EXCLUDES ANY AND ALL WARRANTIES, INCLUDING WITHOUT LIMITATION ANY AND ALL IMPLIED WARRANTIES OF MERCHANTABILITY, FITNESS FOR A PARTICULAR PURPOSE, TITLE, AND AGAINST INFRINGEMENT AND THE LIKE, AND ANY AND ALL WARRANTIES ARISING FROM ANY COURSE OF DEALING OR USAGE OF TRADE. IN NO EVENT SHALL SMSC BE LIABLE FOR ANY DIRECT, INCIDENTAL, INDIRECT, SPECIAL, PUNITIVE, OR CONSEQUENTIAL DAMAGES; OR FOR LOST DATA, PROFITS, SAVINGS OR REVENUES OF ANY KIND; REGARDLESS OF THE FORM OF ACTION, WHETHER BASED ON CONTRACT; TORT; NEGLIGENCE OF SMSC OR OTHERS; STRICT LIABILITY; BREACH OF WARRANTY; OR OTHERWISE; WHETHER OR NOT ANY REMEDY OF BUYER IS HELD TO HAVE FAILED OF ITS ESSENTIAL PURPOSE, AND WHETHER OR NOT SMSC HAS BEEN ADVISED OF THE POSSIBILITY OF SUCH DAMAGES.**

## Package Outline

### EMC1702 Package Drawing (12-Pin QFN 4mm x 4mm)

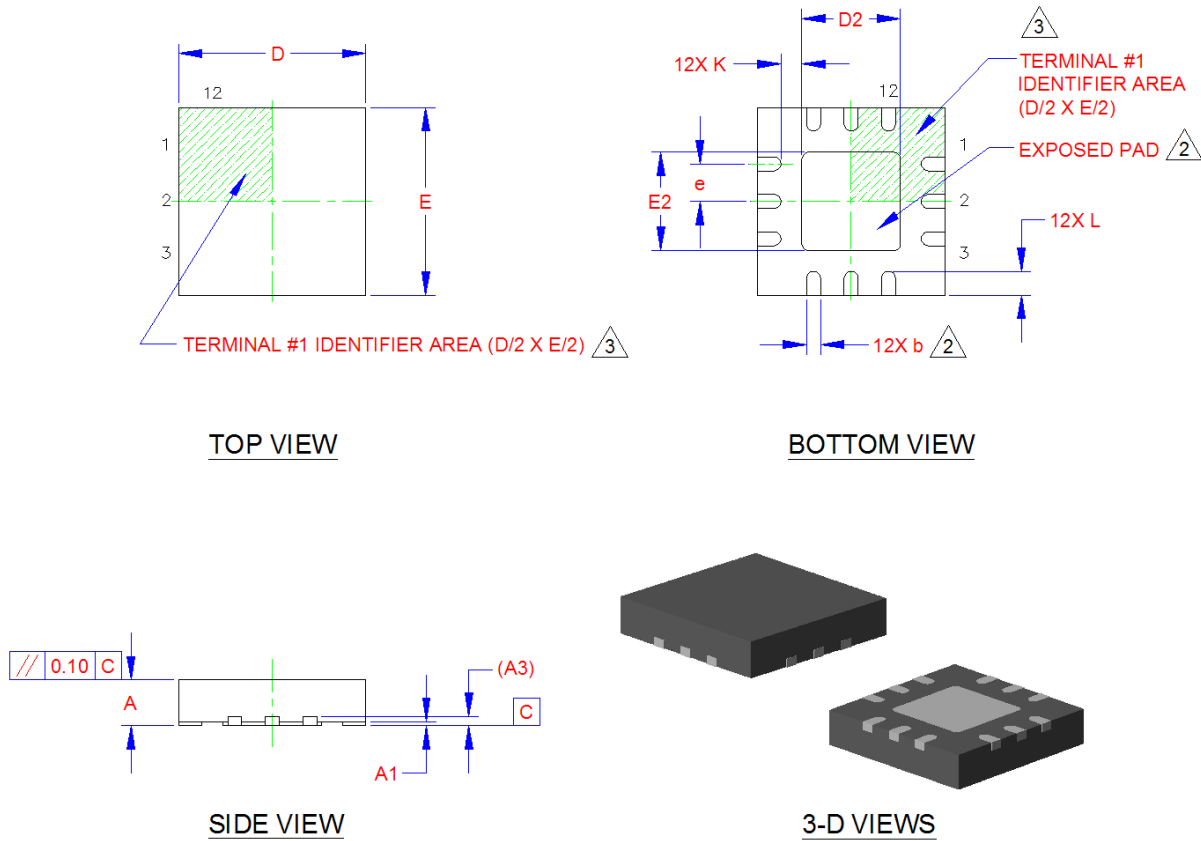
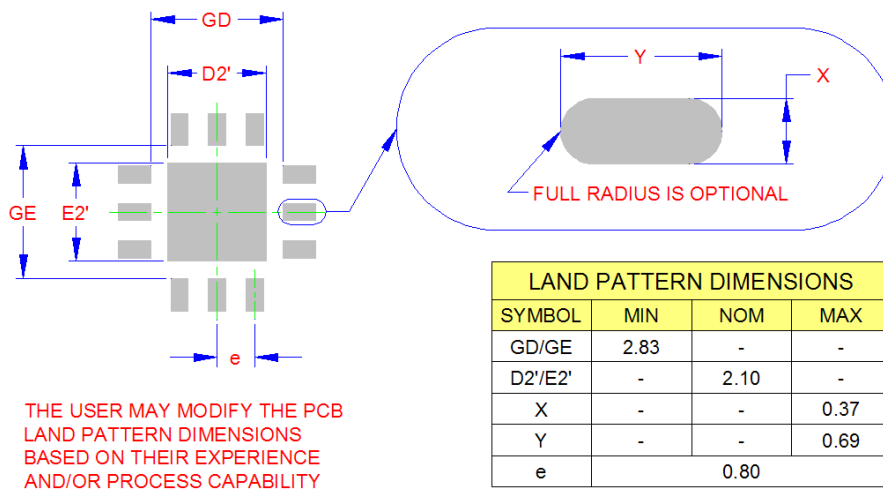

Figure 1 12-Pin QFN 4mm x 4mm Package Drawings

COMMON DIMENSIONS					
SYMBOL	MIN	NOM	MAX	NOTE	REMARK
A	0.80	0.85	0.90	-	OVERALL PACKAGE HEIGHT
A1	0	0.02	0.05	-	STANDOFF
A3	0.20 REF			-	LEAD-FRAME THICKNESS
D/E	3.90	4.00	4.10	-	X/Y BODY SIZE
D2/E2	2.00	2.10	2.20	2	X/Y EXPOSED PAD SIZE
L	0.45	0.50	0.55	-	TERMINAL LENGTH
b	0.25	0.30	0.35	2	TERMINAL WIDTH
K	0.20	-	-	-	TERMINAL TO PAD DISTANCE
e	0.80 BSC			-	TERMINAL PITCH

**NOTES:**

1. ALL DIMENSIONS ARE IN MILLIMETERS.
2. POSITION TOLERANCE OF EACH TERMINAL AND EXPOSED PAD IS  $\pm 0.05\text{mm}$  AT MAXIMUM MATERIAL CONDITION. DIMENSIONS "b" APPLIES TO PLATED TERMINALS AND IT IS MEASURED BETWEEN 0.15 AND 0.30 mm FROM THE TERMINAL TIP.
3. DETAILS OF TERMINAL #1 IDENTIFIER ARE OPTIONAL BUT MUST BE LOCATED WITHIN THE AREA INDICATED.

**Figure 2 12-Pin QFN 4mm x 4mm Package Dimensions and Notes**

RECOMMENDED PCB LAND PATTERN
**Figure 3 12-Pin QFN 4mm x 4mm PCB Footprint**