



MC9S08FL16 Series

Covers: MC9S08FL16 and
MC9S08FL8

MC9S08FL16



32-Pin LQFP
873A-03

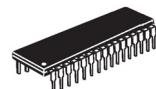

32-Pin SDIP
1376-02

Features:

8-Bit S08 Central Processor Unit (CPU)

- Up to 20 MHz CPU at 4.5 V to 5.5 V across temperature range of -40°C to 85°C
- HC08 instruction set with added BGND instruction
- Support for up to 32 interrupt/reset sources

On-Chip Memory

- Up to 16 KB flash read/program/erase over full operating voltage and temperature
- Up to 1024-byte random-access memory (RAM)
- Security circuitry to prevent unauthorized access to RAM and flash contents

Power-Saving Modes

- Two low power stop modes; reduced power wait mode
- Allows clocks to remain enabled to specific peripherals in stop3 mode

Clock Source Options

- Oscillator (XOSC) — Loop-control Pierce oscillator; crystal or ceramic resonator range of 31.25 kHz to 39.0625 kHz or 1 MHz to 16 MHz
- Internal Clock Source (ICS) — Internal clock source module containing a frequency-locked-loop (FLL) controlled by internal or external reference; precision trimming of internal reference allows 0.2% resolution and 2% deviation over temperature and voltage; supports bus frequencies up to 10 MHz

System Protection

- Watchdog computer operating properly (COP) reset with option to run from dedicated 1 kHz internal clock source or bus clock
- Low-voltage detection with reset or interrupt; selectable trip points
- Illegal opcode detection with reset

- Illegal address detection with reset
- Flash block protection

Development Support

- Single-wire background debug interface
- Breakpoint capability to allow single breakpoint setting during in-circuit debugging (plus two more breakpoints).
- On-chip in-circuit emulator (ICE) debug module containing two comparators and nine trigger modes.

Peripherals

- **IPC** — Interrupt priority controller to provide hardware based nested interrupt mechanism
- **ADC** — 12-channel, 8-bit resolution; 2.5 μs conversion time; automatic compare function; 1.7 mV/ $^{\circ}\text{C}$ temperature sensor; internal bandgap reference channel; operation in stop; optional hardware trigger; fully functional from 4.5 V to 5.5 V
- **TPM** — One 4-channel and one 2-channel timer/pulse-width modulators (TPM) modules; selectable input capture, output compare, or buffered edge- or center-aligned PWM on each channel
- **MTIM16** — One 16-bit modulo timer with optional prescaler
- **SCI** — One serial communications interface module with optional 13-bit break; LIN extensions

Input/Output

- 30 GPIOs including 1 output-only pin and 1 input-only pin

Package Options

- 32-pin SDIP
- 32-pin LQFP

This document contains information on a product under development. Freescale reserves the right to change or discontinue this product without notice.

© Freescale Semiconductor, Inc., 2009. All rights reserved.

Table of Contents

| | | | | |
|-----|--|----|-------------------------------------|----|
| 1 | MCU Block Diagram | 3 | Characteristics | 19 |
| 2 | System Clock Distribution | 4 | 5.9 AC Characteristics | 21 |
| 3 | Pin Assignments | 5 | 5.9.1 Control Timing | 22 |
| 4 | Memory Map | 8 | 5.9.2 TPM Module Timing | 23 |
| 5 | Electrical Characteristics | 9 | 5.10 ADC Characteristics | 24 |
| 5.1 | Introduction | 9 | 5.11 Flash Specifications | 26 |
| 5.2 | Parameter Classification | 9 | 5.12 EMC Performance | 27 |
| 5.3 | Absolute Maximum Ratings | 9 | 5.12.1 Radiated Emissions | 27 |
| 5.4 | Thermal Characteristics | 10 | 6 Ordering Information | 27 |
| 5.5 | ESD Protection and Latch-Up Immunity | 11 | 7 Package Information | 28 |
| 5.6 | DC Characteristics | 12 | 7.1 Mechanical Drawings | 28 |
| 5.7 | Supply Current Characteristics | 17 | | |
| 5.8 | External Oscillator (XOSC) and ICS | | | |

Revision History

To provide the most up-to-date information, the revision of our documents on the World Wide Web will be the most current. Your printed copy may be an earlier revision. To verify you have the latest information available, refer to:

<http://freescale.com/>

The following revision history table summarizes changes contained in this document.

| Rev | Date | Description of Changes |
|-----|----------------|---|
| 1 | March 18, 2009 | Initial public release. |
| 2 | July 20, 2009 | Updated Section 5.12, "EMC Performance." and corrected Figure 1 and Table 1 . Corrected default trim value to 31.25 kHz. |

Related Documentation

Find the most current versions of all documents at: <http://www.freescale.com>

Reference Manual (MC9S08FL16RM)

Contains extensive product information including modes of operation, memory, resets and interrupts, register definition, port pins, CPU, and all module information.

1 MCU Block Diagram

The block diagram, [Figure 1](#), shows the structure of MC9S08FL16 series MCU.

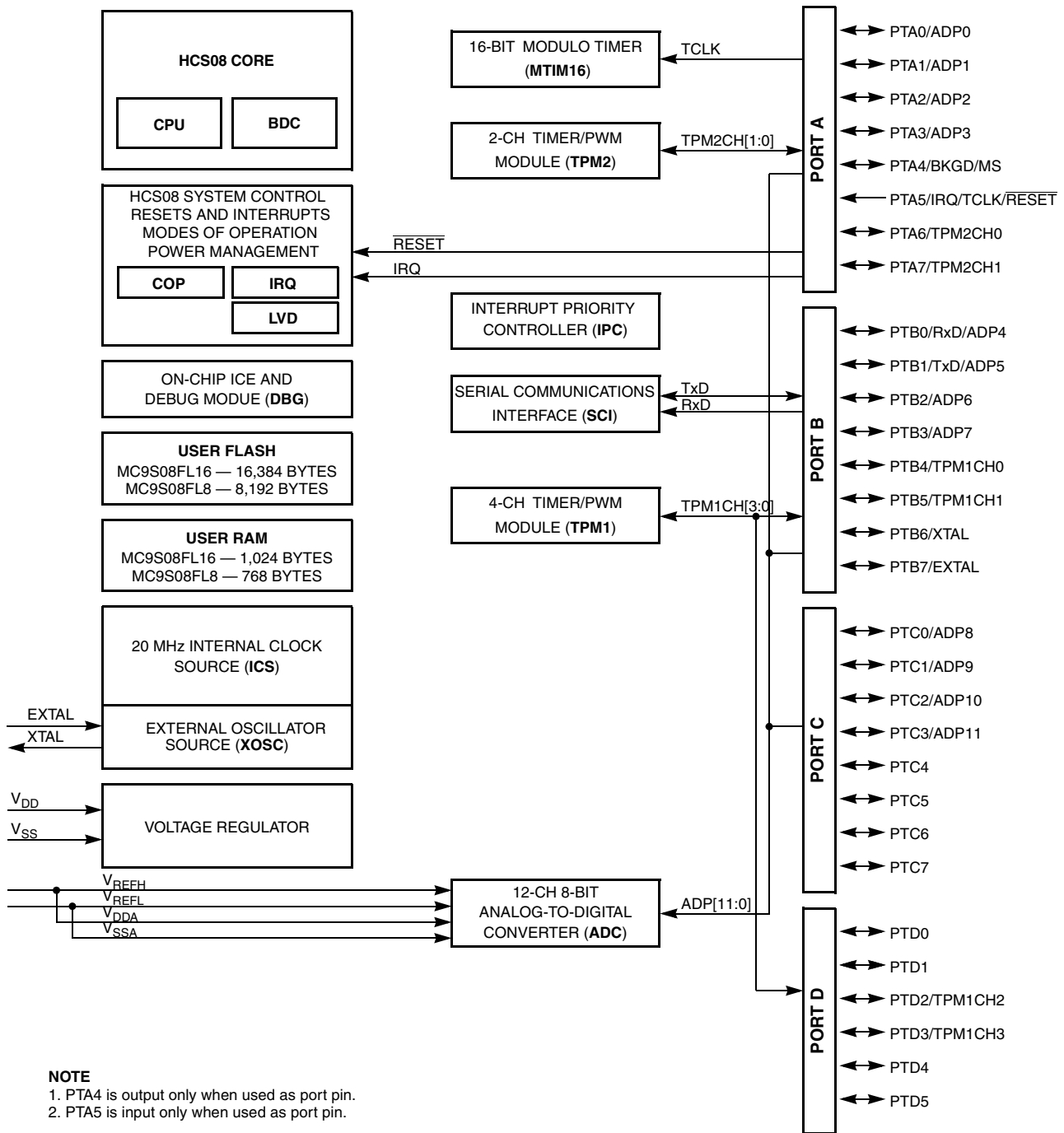

Figure 1. MC9S08FL16 Series Block Diagram

2 System Clock Distribution

MC9S08FL16 series use ICS module as clock sources. The ICS module can use internal or external clock source as reference to provide up to 20 MHz CPU clock. The output of ICS module includes,

- OSCOUT — XOSC output provides external reference clock to ADC.
- ICSFFCLK — ICS fixed frequency clock reference (around 32.768 kHz) provides double of the fixed lock signal to TPMs and MTIM16.
- ICSOUT — ICS CPU clock provides double of the bus clock which is basic clock reference of peripherals.
- ICSLCLK — Alternate BDC clock provides debug signal to BDC module.

The TCLK pin is an extra external clock source. When TCLK is enabled, it can provide alternate clock source to TPMs and MTIM16. The on-chip 1 kHz clock provides clock source of COP module.

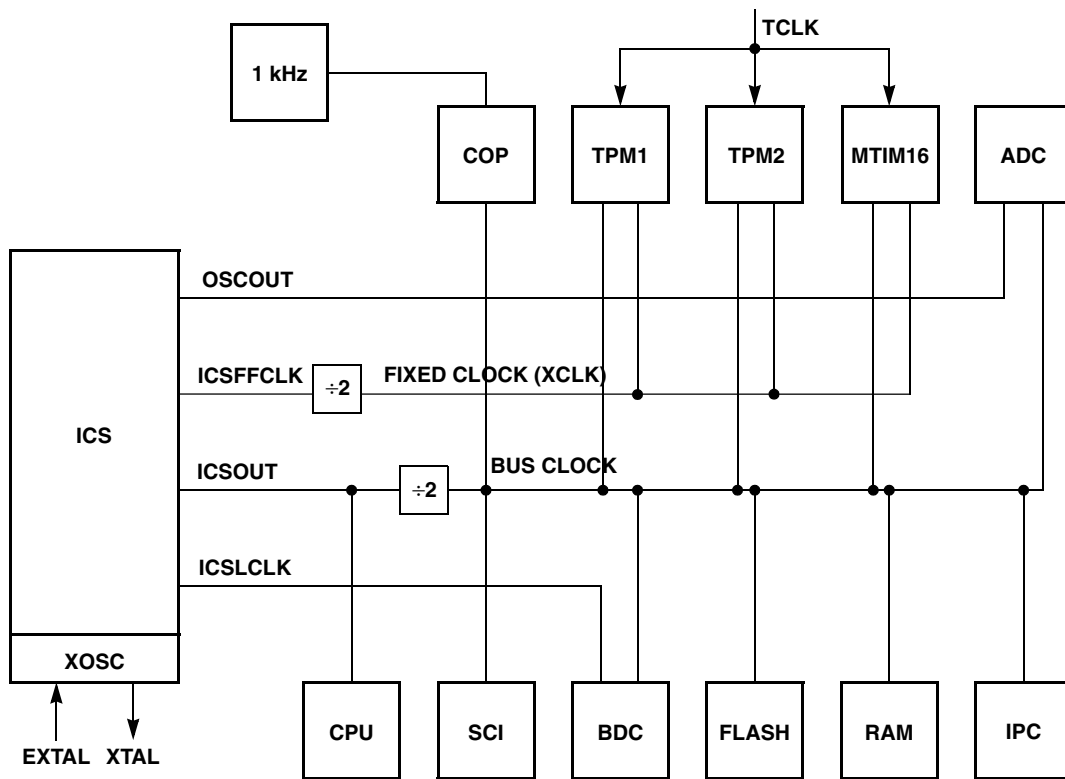

Figure 2. System Clock Distribution Diagram

3 Pin Assignments

This section shows the pin assignments for the MC9S08FL16 series devices.

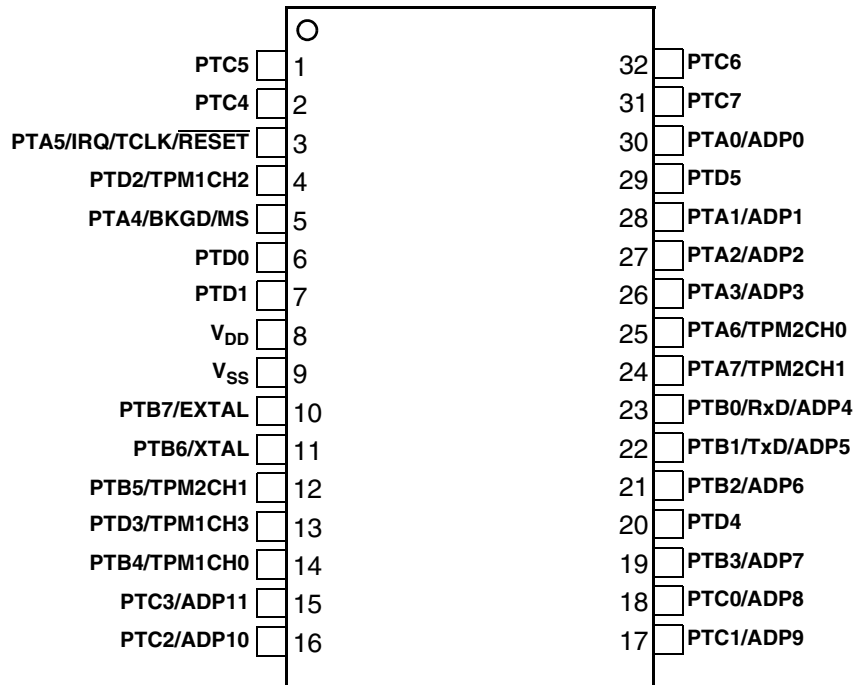

Figure 3. MC9S08FL16 Series 32-Pin SDIP Package

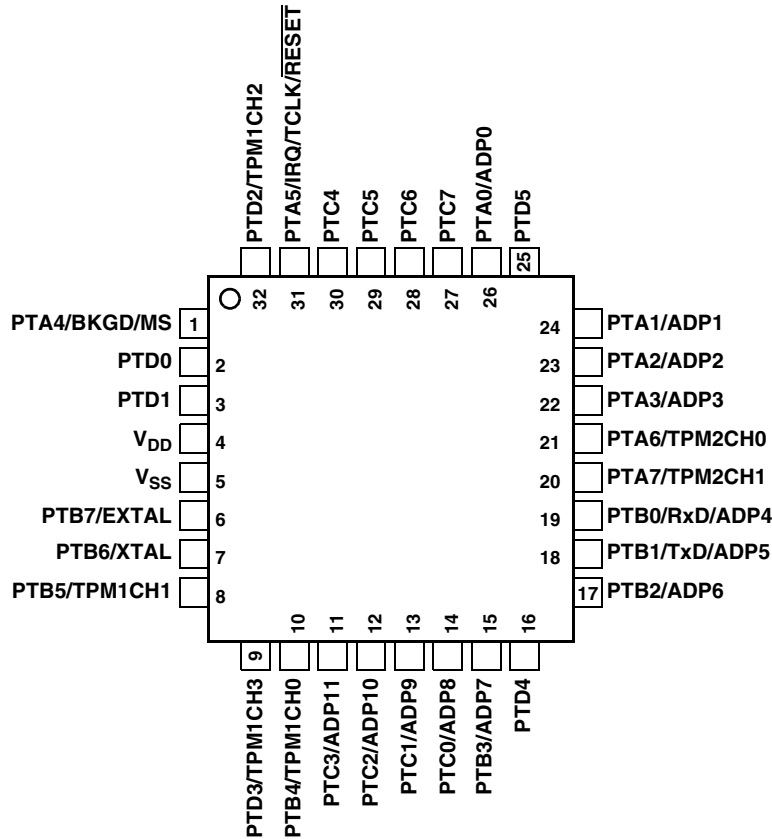

Figure 4. MC9S08FL16 Series 32-Pin LQFP Package

Table 1. Pin Availability by Package Pin-Count

| Pin Number | | <-- Lowest Priority --> Highest | | | | | | | |
|------------|---------|---------------------------------|-----|-------|-----|---------|-----|-----------------|-----|
| 32-SDIP | 32-LQFP | Port Pin | I/O | Alt 1 | I/O | Alt 2 | I/O | Alt 3 | I/O |
| 1 | 29 | PTC5 | I/O | | | | | | |
| 2 | 30 | PTC4 | I/O | | | | | | |
| 3 | 31 | PTA5 | I | IRQ | I | TCLK | I | RESET | I |
| 4 | 32 | PTD2 | I/O | | | TPM1CH2 | I/O | | |
| 5 | 1 | PTA4 | O | | | BKGD | I | MS | I |
| 6 | 2 | PTD0 | I/O | | | | | | |
| 7 | 3 | PTD1 | I/O | | | | | | |
| 8 | 4 | | | | | | | V _{DD} | I |
| 9 | 5 | | | | | | | V _{SS} | I |
| 10 | 6 | PTB7 | I/O | EXTAL | I | | | | |
| 11 | 7 | PTB6 | I/O | XTAL | O | | | | |
| 12 | 8 | PTB5 | I/O | | | TPM1CH1 | I/O | | |
| 13 | 9 | PTD3 | I/O | | | TPM1CH3 | I/O | | |
| 14 | 10 | PTB4 | I/O | | | TPM1CH0 | I/O | | |
| 15 | 11 | PTC3 | I/O | | | ADP11 | I | | |

Table 1. Pin Availability by Package Pin-Count (continued)

| Pin Number | | <-- Lowest Priority --> Highest | | | | | | | |
|------------|---------|---------------------------------|-----|-------|-----|---------|-----|-------|-----|
| 32-SDIP | 32-LQFP | Port Pin | I/O | Alt 1 | I/O | Alt 2 | I/O | Alt 3 | I/O |
| 16 | 12 | PTC2 | I/O | | | ADP10 | I | | |
| 17 | 13 | PTC1 | I/O | | | ADP9 | I | | |
| 18 | 14 | PTC0 | I/O | | | ADP8 | I | | |
| 19 | 15 | PTB3 | I/O | | | ADP7 | I | | |
| 20 | 16 | PTD4 | I/O | | | | | | |
| 21 | 17 | PTB2 | I/O | | | ADP6 | I | | |
| 22 | 18 | PTB1 | I/O | | | TxD | I/O | ADP5 | I |
| 23 | 19 | PTB0 | I/O | | | RxD | I | ADP4 | I |
| 24 | 20 | PTA7 | I/O | | | TPM2CH1 | I/O | | |
| 25 | 21 | PTA6 | I/O | | | TPM2CH0 | I/O | | |
| 26 | 22 | PTA3 | I/O | | | ADP3 | I | | |
| 27 | 23 | PTA2 | I/O | | | ADP2 | I | | |
| 28 | 24 | PTA1 | I/O | | | ADP1 | I | | |
| 29 | 25 | PTD5 | I/O | | | | | | |
| 30 | 26 | PTA0 | I/O | | | ADP0 | I | | |
| 31 | 27 | PTC7 | I/O | | | | | | |
| 32 | 28 | PTC6 | I/O | | | | | | |

NOTE

When an alternative function is first enabled, it is possible to get a spurious edge to the module. User software must clear out any associated flags before interrupts are enabled. [Table 1](#) illustrates the priority if multiple modules are enabled. The highest priority module will have control over the pin. Selecting a higher priority pin function with a lower priority function already enabled can cause spurious edges to the lower priority module. Disable all modules that share a pin before enabling another module.

4 Memory Map

Figure 5 shows the memory map for the MC9S08FL16 series. On-chip memory in the MC9S08FL16 series of MCUs consists of RAM, flash program memory for nonvolatile data storage, plus I/O and control/status registers. The registers are divided into two groups:

- Direct-page registers (0x0000 through 0x003F)
- High-page registers (0x1800 through 0x187F)

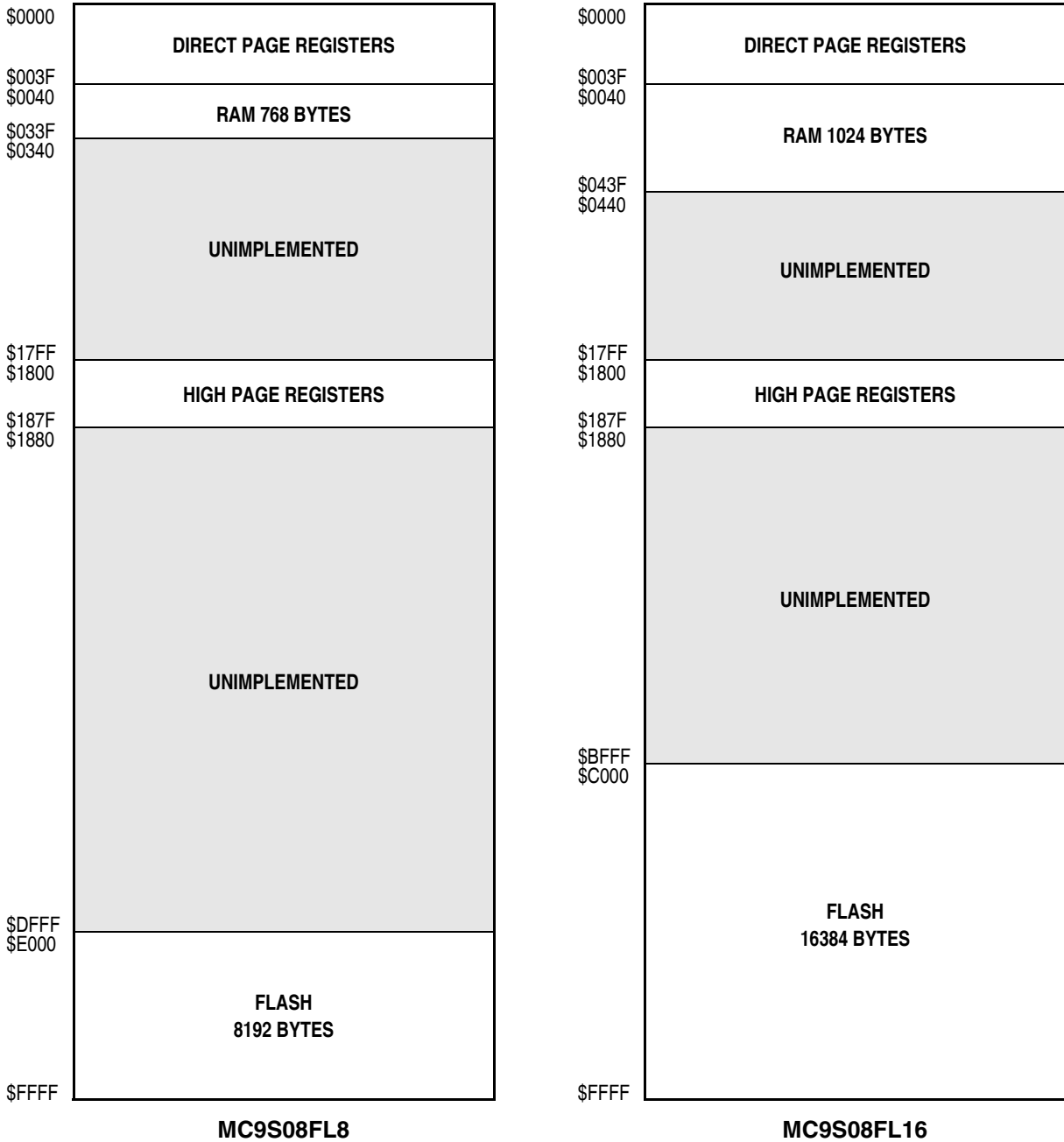

Figure 5. MC9S08FL16 Series Memory Map

5 Electrical Characteristics

5.1 Introduction

This section contains electrical and timing specifications for the MC9S08FL16 series of microcontrollers available at the time of publication.

5.2 Parameter Classification

The electrical parameters shown in this supplement are guaranteed by various methods. To give the customer a better understanding, the following classification is used and the parameters are tagged accordingly in the tables where appropriate:

Table 2. Parameter Classifications

| | |
|----------|--|
| P | Those parameters are guaranteed during production testing on each individual device. |
| C | Those parameters are achieved by the design characterization by measuring a statistically relevant sample size across process variations. |
| T | Those parameters are achieved by design characterization on a small sample size from typical devices under typical conditions unless otherwise noted. All values shown in the typical column are within this category. |
| D | Those parameters are derived mainly from simulations. |

NOTE

The classification is shown in the column labeled “C” in the parameter tables where appropriate.

5.3 Absolute Maximum Ratings

Absolute maximum ratings are stress ratings only, and functional operation at the maxima is not guaranteed. Stress beyond the limits specified in [Table 3](#) may affect device reliability or cause permanent damage to the device. For functional operating conditions, refer to the remaining tables in this section.

This device contains circuitry protecting against damage due to high static voltage or electrical fields; however, it is advised that normal precautions be taken to avoid application of any voltages higher than maximum-rated voltages to this high-impedance circuit. Reliability of operation is enhanced if unused inputs are tied to an appropriate logic voltage level (for instance, either V_{SS} or V_{DD}) or the programmable pullup resistor associated with the pin is enabled.

Table 3. Absolute Maximum Ratings

| Rating | Symbol | Value | Unit |
|---|-----------|------------------------|------|
| Supply voltage | V_{DD} | -0.3 to 5.8 | V |
| Maximum current into V_{DD} | I_{DD} | 120 | mA |
| Digital input voltage | V_{In} | -0.3 to $V_{DD} + 0.3$ | V |
| Instantaneous maximum current Single pin limit (applies to all port pins) ^{1, 2, 3} | I_D | ±25 | mA |
| Storage temperature range | T_{stg} | -55 to 150 | °C |

- ¹ Input must be current limited to the value specified. To determine the value of the required current-limiting resistor, calculate resistance values for positive (V_{DD}) and negative (V_{SS}) clamp voltages, then use the larger of the two resistance values.
- ² All functional non-supply pins, except for PTA5 are internally clamped to V_{SS} and V_{DD} .
- ³ Power supply must maintain regulation within operating V_{DD} range during instantaneous and operating maximum current conditions. If positive injection current ($V_{In} > V_{DD}$) is greater than I_{DD} , the injection current may flow out of V_{DD} and could result in external power supply going out of regulation. Ensure external V_{DD} load will shunt current greater than maximum injection current. This will be the greatest risk when the MCU is not consuming power. Examples are: if no system clock is present, or if the clock rate is very low (which would reduce overall power consumption).

5.4 Thermal Characteristics

This section provides information about operating temperature range, power dissipation, and package thermal resistance. Power dissipation on I/O pins is usually small compared to the power dissipation in on-chip logic and voltage regulator circuits, and it is user-determined rather than being controlled by the MCU design. To take $P_{I/O}$ into account in power calculations, determine the difference between actual pin voltage and V_{SS} or V_{DD} and multiply by the pin current for each I/O pin. Except in cases of unusually high pin current (heavy loads), the difference between pin voltage and V_{SS} or V_{DD} will be very small.

Table 4. Thermal Characteristics

| Rating | Symbol | Value | Unit |
|--|---------------|-----------------------------|------|
| Operating temperature range (packaged) | T_A | T_L to T_H -40 to 85 | °C |
| Thermal resistance Single-layer board | | | |
| 32-pin SDIP | θ_{JA} | 60 | °C/W |
| 32-pin LQFP | | 85 | |
| Thermal resistance Four-layer board | | | |
| 32-pin SDIP | θ_{JA} | 35 | °C/W |
| 32-pin LQFP | | 56 | |

The average chip-junction temperature (T_J) in °C can be obtained from:

$$T_J = T_A + (P_D \times \theta_{JA}) \quad \text{Eqn. 1}$$

where:

T_A = Ambient temperature, °C

θ_{JA} = Package thermal resistance, junction-to-ambient, °C/W

$P_D = P_{int} + P_{I/O}$

$P_{int} = I_{DD} \times V_{DD}$, Watts — chip internal power

$P_{I/O}$ = Power dissipation on input and output pins — user determined

For most applications, $P_{I/O}$ far much smaller than P_{int} and can be neglected. An approximate relationship between P_D and T_J (if $P_{I/O}$ is neglected) is:

$$P_D = K \div (T_J + 273 \text{ °C}) \quad \text{Eqn. 2}$$

Solving [Equation 1](#) and [Equation 2](#) for K gives:

$$K = P_D \times (T_A + 273 \text{ °C}) + \theta_{JA} \times (P_D)^2 \quad \text{Eqn. 3}$$

where K is a constant pertaining to the particular part. K can be determined from [Equation 3](#) by measuring P_D (at equilibrium) for an known T_A . Using this value of K, the values of P_D and T_J can be obtained by solving [Equation 1](#) and [Equation 2](#) iteratively for any value of T_A .

5.5 ESD Protection and Latch-Up Immunity

Although damage from electrostatic discharge (ESD) is much less common on these devices than on early CMOS circuits, normal handling precautions must be taken to avoid exposure to static discharge. Qualification tests are performed to ensure that these devices can withstand exposure to reasonable levels of static without suffering any permanent damage.

During the device qualification, ESD stresses were performed for the human body model (HBM) and the charge device model (CDM).

A device is defined as a failure if after exposure to ESD pulses the device no longer meets the device specification. Complete DC parametric and functional testing is performed per the applicable device specification at room temperature followed by hot temperature, unless instructed otherwise in the device specification.

Table 5. ESD and Latch-Up Test Conditions

| Model | Description | Symbol | Value | Unit |
|------------|-----------------------------|--------|-------|------|
| Human body | Series resistance | R1 | 1500 | Ω |
| | Storage capacitance | C | 100 | pF |
| | Number of pulses per pin | — | 3 | — |
| Latch-up | Minimum input voltage limit | — | -2.5 | V |
| | Maximum input voltage limit | — | 7.5 | V |

Table 6. ESD and Latch-Up Protection Characteristics

| No. | Rating ¹ | Symbol | Min | Max | Unit |
|-----|--|-----------|------------|-----|------|
| 1 | Human body model (HBM) | V_{HBM} | ± 2000 | — | V |
| 2 | Charge device model (CDM) | V_{CDM} | ± 500 | — | V |
| 3 | Latch-up current at $T_A = 85\text{ }^\circ\text{C}$ | I_{LAT} | ± 100 | — | mA |

¹ Parameter is achieved by design characterization on a small sample size from typical devices under typical conditions unless otherwise noted.

5.6 DC Characteristics

This section includes information about power supply requirements and I/O pin characteristics.

Table 7. DC Characteristics

| Num | C | Characteristic | Symbol | Condition | Min. | Typical ¹ | Max. | Unit |
|-----|---|--|---|---|----------------------|----------------------|----------------------|---------------|
| 1 | P | Operating voltage | — | — | 4.5 | — | 5.5 | V |
| 2 | C | Output high voltage | V_{OH} | All I/O pins, low-drive strength $I_{Load} = -2\text{ mA}$ | $V_{DD} - 1.5$ | — | — | V |
| | P | | | All I/O pins, high-drive strength $I_{Load} = -10\text{ mA}$ | $V_{DD} - 1.5$ | — | — | |
| 3 | D | Output high current Max total I_{OH} for all ports | I_{OHT} | — | — | — | 100 | mA |
| 4 | C | Output low voltage | V_{OL} | All I/O pins, low-drive strength $I_{Load} = 2\text{ mA}$ | — | — | 1.5 | V |
| | P | | | All I/O pins, high-drive strength $I_{Load} = 10\text{ mA}$ | — | — | 1.5 | |
| 5 | D | Output low current Max total I_{OL} for all ports | I_{OLT} | — | — | — | 100 | mA |
| 6 | P | Input high voltage All digital inputs | V_{IH} | — | $0.65 \times V_{DD}$ | — | — | V |
| 7 | P | Input low voltage All digital inputs | V_{IL} | — | — | — | $0.35 \times V_{DD}$ | V |
| 8 | C | Input hysteresis All digital inputs | V_{hys} | — | $0.06 \times V_{DD}$ | — | — | mV |
| 9 | P | Input leakage current All input only pins (per pin) | $ I_{In} $ | $V_{In} = V_{DD}$ or V_{SS} | — | 0.1 | 1 | μA |
| 10 | P | Hi-Z (off-state) leakage current All input/output (per pin) | $ I_{OZ} $ | $V_{In} = V_{DD}$ or V_{SS} | — | 0.1 | 1 | μA |
| 11a | C | Pullup, pulldown resistors All digital inputs, when enabled (all I/O pins other than PTA5/IRQ/TCLK/RESET) | R_{PU} , R_{PD} | — | 17.5 | 36.5 | 52.5 | $k\Omega$ |
| 11b | C | Pullup, pulldown resistors (PTA5/IRQ/TCLK/RESET) | R_{PU} , R_{PD} (Note ²) | — | 17.5 | 36.5 | 52.5 | $k\Omega$ |

Table 7. DC Characteristics (continued)

| Num | C | Characteristic | Symbol | Condition | Min. | Typical ¹ | Max. | Unit | |
|-----|---|--|------------|------------------------------------|------------------|----------------------|------|------|---|
| 12 | C | DC injection current ^{3, 4, 5} | I_{IC} | $V_{IN} < V_{SS}, V_{IN} > V_{DD}$ | -0.2 | — | 0.2 | mA | |
| | | Single pin limit Total MCU limit, includes sum of all stressed pins | | | -5 | — | 5 | mA | |
| 13 | C | Input capacitance, all pins | C_{In} | — | — | — | 8 | pF | |
| 14 | C | RAM retention voltage | V_{RAM} | — | — | 0.6 | 1.0 | V | |
| 15 | C | POR re-arm voltage ⁶ | V_{POR} | — | 0.9 | 1.4 | 2.0 | V | |
| 16 | D | POR re-arm time | t_{POR} | — | 10 | — | — | μs | |
| 17 | P | Low-voltage detection threshold — high range | V_{LVD1} | — | V_{DD} falling | 3.9 | 4.0 | 4.1 | V |
| | | V_{DD} rising | | | 4.0 | 4.1 | 4.2 | | |
| 17 | P | Low-voltage detection threshold — low range | V_{LVD0} | — | V_{DD} falling | 2.48 | 2.56 | 2.64 | V |
| | | V_{DD} rising | | | 2.54 | 2.62 | 2.70 | | |
| 18 | C | Low-voltage warning threshold — high range 1 | V_{LVW3} | — | V_{DD} falling | 4.5 | 4.6 | 4.7 | V |
| | | V_{DD} rising | | | 4.6 | 4.7 | 4.8 | | |
| 18 | P | Low-voltage warning threshold — high range 0 | V_{LVW2} | — | V_{DD} falling | 4.2 | 4.3 | 4.4 | V |
| | | V_{DD} rising | | | 4.3 | 4.4 | 4.5 | | |
| 19 | P | Low-voltage warning threshold low range 1 | V_{LVW1} | — | V_{DD} falling | 2.84 | 2.92 | 3.00 | V |
| | | V_{DD} rising | | | 2.90 | 2.98 | 3.06 | | |
| 19 | C | Low-voltage warning threshold — low range 0 | V_{LVW0} | — | V_{DD} falling | 2.66 | 2.74 | 2.82 | V |
| | | V_{DD} rising | | | 2.72 | 2.80 | 2.88 | | |
| 20 | C | Low-voltage inhibit reset/recover hysteresis | V_{hys} | — | — | 100 | — | mV | |
| 21 | C | Bandgap voltage reference ⁷ | V_{BG} | — | — | 1.21 | — | V | |

¹ Typical values are measured at 25 °C. Characterized, not tested.

² The specified resistor value is the actual value internal to the device. The pullup or pulldown value may appear higher when measured externally on the pin.

³ All functional non-supply pins, except for PTA5 are internally clamped to V_{SS} and V_{DD} .

⁴ Input must be current limited to the value specified. To determine the value of the required current-limiting resistor, calculate resistance values for positive and negative clamp voltages, then use the larger of the two values.

⁵ Power supply must maintain regulation within operating V_{DD} range during instantaneous and operating maximum current conditions. If the positive injection current ($V_{In} > V_{DD}$) is greater than I_{DD} , the injection current may flow out of V_{DD} and could result in external power supply going out of regulation. Ensure that external V_{DD} load will shunt current greater than maximum injection current. This will be the greatest risk when the MCU is not consuming power. Examples are: if no system clock is present, or if clock rate is very low (which would reduce overall power consumption).

⁶ Maximum is highest voltage that POR is guaranteed.

⁷ Factory trimmed at $V_{DD} = 5.0$ V, Temp = 25 °C

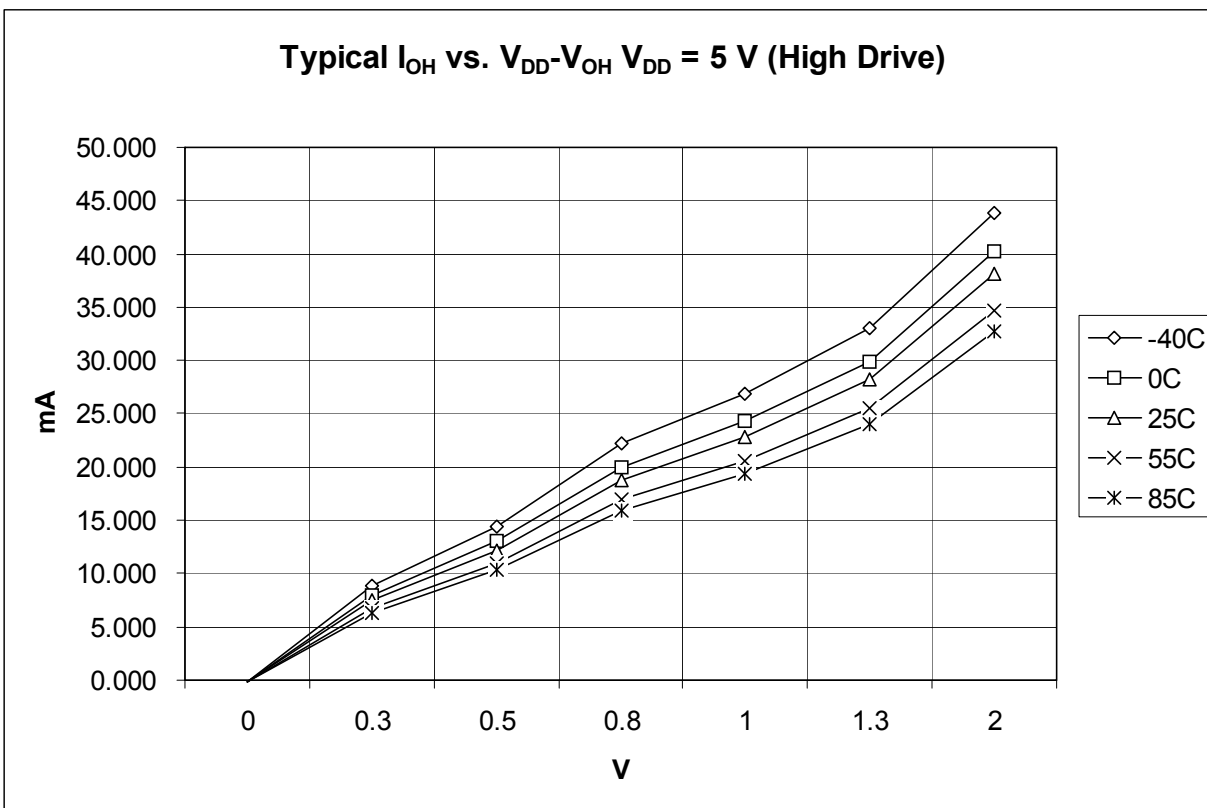

Figure 6. Typical I_{OH} Vs $V_{DD}-V_{OH}$ ($V_{DD} = 5.0\text{ V}$) (High Drive)

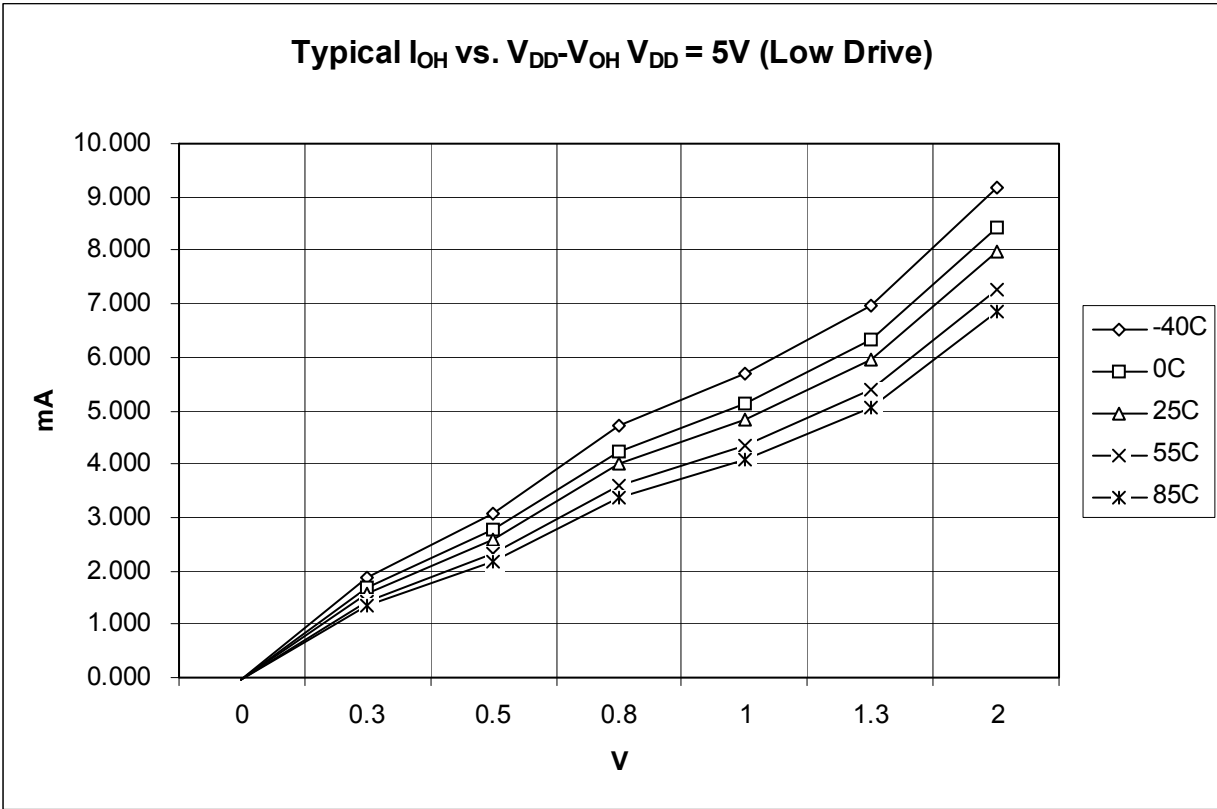

Figure 7. Typical I_{OH} Vs $V_{DD}-V_{OH}$ ($V_{DD} = 5.0 V$) (Low Drive)

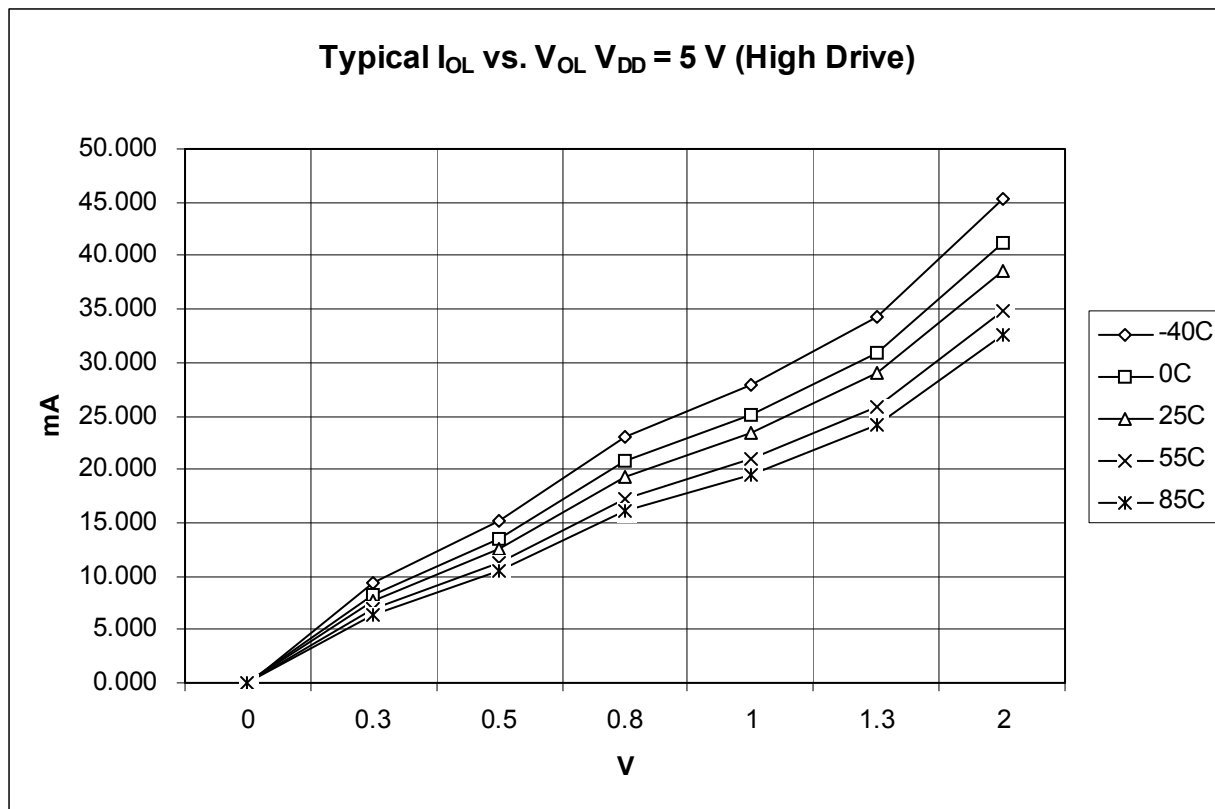

Figure 8. Typical I_{OH} Vs V_{OL} ($V_{DD} = 5.0\text{ V}$) (High Drive)

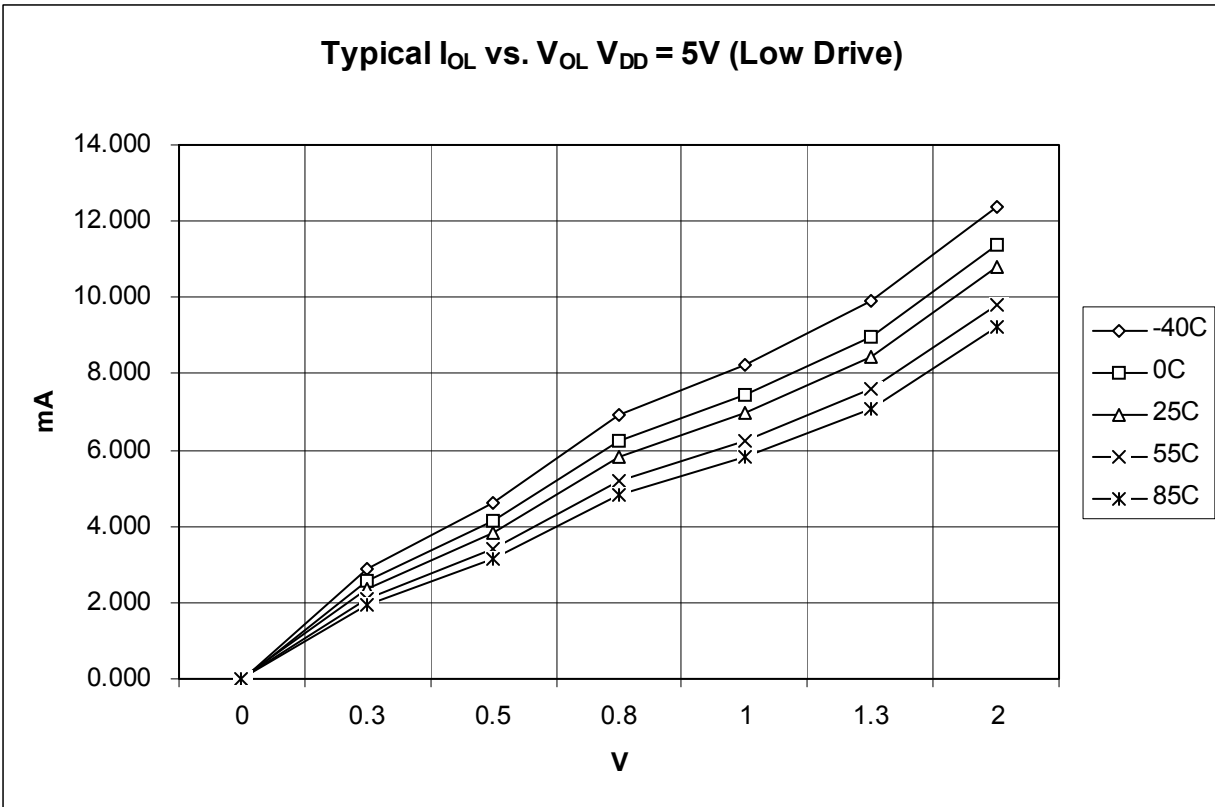

Figure 9. Typical I_{OH} Vs V_{OL} ($V_{DD} = 5.0 V$) (Low Drive)

5.7 Supply Current Characteristics

This section includes information about power supply current in various operating modes.

Table 8. Supply Current Characteristics

| Num | C | Parameter | Symbol | Bus Freq | V _{DD} (V) | Typical ¹ | Max | Unit | Temp |
|-----|---|---|--------------------|----------|---------------------|----------------------|-----|------|--------------------------|
| 1 | P | Run supply current FEI mode, all modules off | R _I DD | 10 MHz | 5 | 5.66 5.75 5.80 | — | mA | −40 °C 25 °C 85 °C |
| | P | | | 1 MHz | | 1.61 1.65 1.78 | — | | −40 °C 25 °C 85 °C |
| 2 | C | Wait mode supply current FEI mode, all modules off | W _I DD | 10 MHz | 5 | 2.79 2.86 2.88 | — | μA | −40 °C 25 °C 85 °C |
| | C | | | 1 MHz | | 1.05 1.06 1.06 | — | | −40 °C 25 °C 85 °C |
| 3 | C | Stop2 mode supply current | S2 _I DD | — | 5 | 1.06 | — | μA | −40 to 85 °C |
| | C | Stop3 mode supply current no clocks active | S3 _I DD | — | 5 | 1.17 | — | μA | −40 to 85 °C |
| 4 | C | ADC adder to stop3 | — | — | 5 | 163.88 | — | μA | 25 °C |
| 5 | C | ICS adder to stop3 EREFSTEN = 1 | — | — | 5 | 1.25 | — | μA | 25 °C |
| 6 | C | LVD adder to stop3 | — | — | 5 | 161.3 | — | μA | 25 °C |

¹ Data in Typical column was characterized at 5.0 V, 25 °C or is typical recommended value.

5.8 External Oscillator (XOSC) and ICS Characteristics

Refer to [Figure 11](#) for crystal or resonator circuits.

Table 9. XOSC and ICS Specifications (Temperature Range = -40 to 85 °C Ambient)

| Num | C | Characteristic | Symbol | Min | Typical ¹ | Max | Unit |
|-----|---|---|--------------------------|-----------------------|--------------------------|--------------------|--------------------------|
| 1 | C | Oscillator crystal or resonator (EREFS = 1, ERCLKEN = 1) Low range (RANGE = 0) | f_{lo} | 32 | — | 38.4 | kHz MHz MHz MHz |
| | | High range (RANGE = 1) FEE or FBE mode ² | f_{hi} | 1 | — | 5 | |
| | | High range (RANGE = 1), high gain (HGO = 1), FBELP mode | f_{hi} | 1 | — | 16 | |
| | | High range (RANGE = 1), low power (HGO = 0), FBELP mode | f_{hi} | 1 | — | 8 | |
| 2 | D | Load capacitors | C_1 C_2 | See Note ³ | | | |
| 3 | D | Feedback resistor | R_F | | 10 | | M Ω M Ω |
| | | Low range (32 kHz to 38.4 kHz) High range (1 MHz to 16 MHz) | | | 1 | | |
| 4 | D | Series resistor — Low range | R_S | | 0 | | k Ω |
| | | Low gain (HGO = 0) High gain (HGO = 1) | | | 100 | | |
| 5 | D | Series resistor — High range | R_S | | 0 | 0 | k Ω |
| | | Low Gain (HGO = 0) | | | 0 | 10 | |
| | | High Gain (HGO = 1) | | | 0 | 20 | |
| | | ≥ 8 MHz 4 MHz 1 MHz | | | 0 | 20 | |
| 6 | C | Crystal startup time ^{4, 5} | t_{CSTL} t_{CSTH} | | 200 | | ms |
| | | Low range, low power | | | 400 | | |
| | | Low range, high power | | | 5 | | |
| | | High range, low power | | | 15 | | |
| 7 | T | Internal reference start-up time | t_{IRST} | | 60 | 100 | μ s |
| | | High range, high power | | | 15 | | |
| 8 | D | Square wave input clock frequency (EREFS = 0, ERCLKEN = 1) | f_{extal} | 0.03125 | — | 5 | MHz MHz |
| | | FEE or FBE mode ² FBELP mode | | 0 | — | 20 | |
| 9 | P | Average internal reference frequency — trimmed | f_{int_t} | — | 31.25 | — | kHz |
| 10 | P | DCO output frequency range — trimmed ⁶ Low range (DRS = 00) | f_{dco_t} | 16 | — | 20 | MHz |
| 11 | C | Total deviation of DCO output from trimmed frequency ⁴ Over full voltage and temperature range Over fixed voltage and temperature range of 0 to 70°C | Δf_{dco_t} | — | -1.0 to 0.5 ± 0.5 | ± 2 ± 1 | % f_{dco} |
| 12 | C | FLL acquisition time ^{4,7} | $t_{Acquire}$ | | | 1 | ms |

Table 9. XOSC and ICS Specifications (Temperature Range = -40 to 85 °C Ambient) (continued)

| Num | C | Characteristic | Symbol | Min | Typical ¹ | Max | Unit |
|-----|---|---|---------------------|-----|----------------------|-----|-------------------|
| 13 | C | Long term jitter of DCO output clock (averaged over 2 ms interval) ⁸ | C _{Jitter} | — | 0.02 | 0.2 | %f _{dco} |

- ¹ Data in Typical column was characterized at 3.0 V, 25 °C or is typical recommended value.
- ² When ICS is configured for FEE or FBE mode, input clock source must be divisible using RDIV to within the range of 31.25 kHz to 39.0625 kHz.
- ³ See crystal or resonator manufacturer’s recommendation.
- ⁴ This parameter is characterized and not tested on each device.
- ⁵ Proper PC board layout procedures must be followed to achieve specifications.
- ⁶ The resulting bus clock frequency should not exceed the maximum specified bus clock frequency of the device.
- ⁷ This specification applies to any time the FLL reference source or reference divider is changed, trim value changed, DMX32 bit is changed, DRS bit is changed, or changing from FLL disabled (FBELP, FBILP) to FLL enabled (FEI, FEE, FBE, FBI). If a crystal/resonator is being used as the reference, this specification assumes it is already running.
- ⁸ Jitter is the average deviation from the programmed frequency measured over the specified interval at maximum f_{Bus}. Measurements are made with the device powered by filtered supplies and clocked by a stable external clock signal. Noise injected into the FLL circuitry via V_{DD} and V_{SS} and variation in crystal oscillator frequency increase the C_{Jitter} percentage for a given interval.

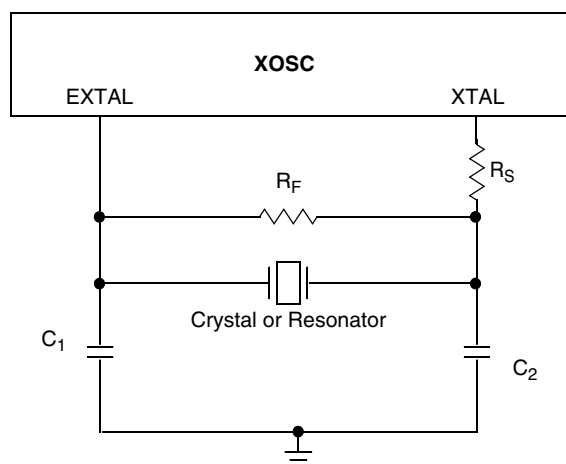

Figure 10. Typical Crystal or Resonator Circuit

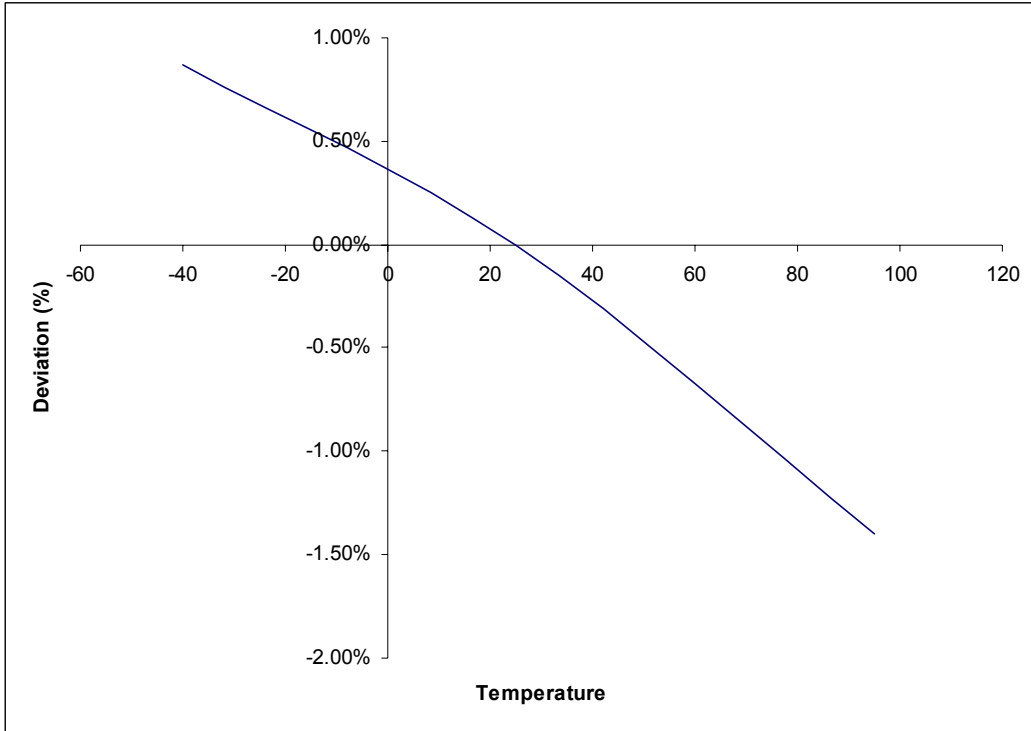

Figure 11. Deviation of DCO Output from Trimmed Frequency (20 MHz, 5.0 V)

5.9 AC Characteristics

This section describes timing characteristics for each peripheral system.

5.9.1 Control Timing

Table 10. Control Timing

| Num | C | Rating | Symbol | Min | Typical ¹ | Max | Unit |
|-----|---|---|----------------------|-----------------------------|----------------------|--------|---------|
| 1 | D | Bus frequency ($t_{cyc} = 1/f_{Bus}$) | f_{Bus} | dc | — | 10 | MHz |
| 2 | D | Internal low power oscillator period | t_{LPO} | 700 | — | 1300 | μs |
| 3 | D | External reset pulse width ² | t_{extrst} | 100 | — | — | ns |
| 4 | D | Reset low drive | t_{rstdrv} | $34 \times t_{cyc}$ | — | — | ns |
| 5 | D | BKGD/MS setup time after issuing background debug force reset to enter user or BDM modes | t_{MSSU} | 500 | — | — | ns |
| 6 | D | BKGD/MS hold time after issuing background debug force reset to enter user or BDM modes ³ | t_{MSH} | 100 | — | — | μs |
| 7 | D | IRQ pulse width Asynchronous path ² Synchronous path ⁴ | t_{LIH}, t_{HIL} | 100 $1.5 \times t_{cyc}$ | — — | — — | ns |
| 8 | D | Keyboard interrupt pulse width Asynchronous path ² Synchronous path ⁴ | t_{LIH}, t_{HIL} | 100 $1.5 \times t_{cyc}$ | — — | — — | ns |
| 9 | C | Port rise and fall time — Low output drive (PTxDS = 0) (load = 50 pF) ⁵ Slew rate control disabled (PTxSE = 0) Slew rate control enabled (PTxSE = 1) | t_{Rise}, t_{Fall} | — — | 16 23 | — — | ns |
| | | Port rise and fall time — High output drive (PTxDS = 1) (load = 50 pF) ⁵ Slew rate control disabled (PTxSE = 0) Slew rate control enabled (PTxSE = 1) | t_{Rise}, t_{Fall} | — — | 5 9 | — — | ns |

- ¹ Typical values are based on characterization data at $V_{DD} = 5.0 V$, 25 °C unless otherwise stated.
- ² This is the shortest pulse that is guaranteed to be recognized as a reset pin request.
- ³ To enter BDM mode following a POR, BKGD/MS must be held low during the power-up and for a hold time of t_{MSH} after V_{DD} rises above V_{LVD} .
- ⁴ This is the minimum pulse width that is guaranteed to pass through the pin synchronization circuitry. Shorter pulses may or may not be recognized. In stop mode, the synchronizer is bypassed so shorter pulses can be recognized.
- ⁵ Timing is shown with respect to 20% V_{DD} and 80% V_{DD} levels. Temperature range -40 °C to 85 °C.

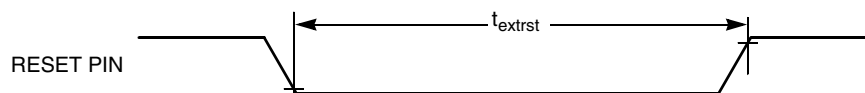
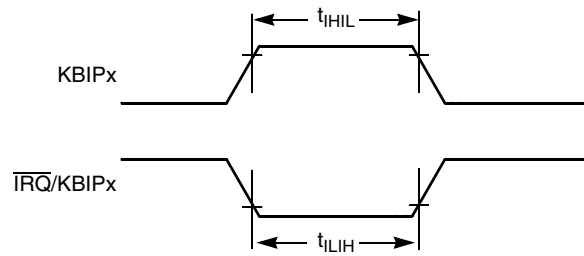

Figure 12. Reset Timing

 Figure 13. $\overline{\text{IRQ}}/\text{KBIPx}$ Timing

5.9.2 TPM Module Timing

Synchronizer circuits determine the shortest input pulses that can be recognized or the fastest clock that can be used as the optional external source to the timer counter. These synchronizers operate from the current bus rate clock.

Table 11. TPM Input Timing

| No. | C | Function | Symbol | Min | Max | Unit |
|-----|---|---------------------------|-------------------|-----|--------------------|------------------|
| 1 | D | External clock frequency | f_{TCLK} | 0 | $f_{\text{Bus}}/4$ | Hz |
| 2 | D | External clock period | t_{TCLK} | 4 | — | t_{cyc} |
| 3 | D | External clock high time | t_{clkh} | 1.5 | — | t_{cyc} |
| 4 | D | External clock low time | t_{clkl} | 1.5 | — | t_{cyc} |
| 5 | D | Input capture pulse width | t_{ICPW} | 1.5 | — | t_{cyc} |

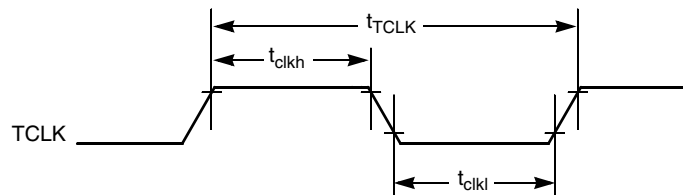

Figure 14. Timer External Clock

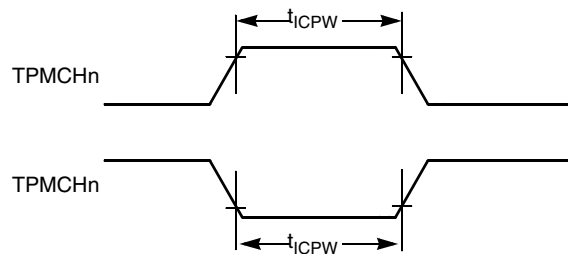

Figure 15. Timer Input Capture Pulse

5.10 ADC Characteristics

Table 12. 8-Bit ADC Operating Conditions

| Characteristic | Conditions | Symb | Min | Typical ¹ | Max | Unit | Comment |
|--------------------------------|---|------------------|------------|----------------------|------------|------------|-----------------|
| Supply voltage | Absolute | V_{DDA} | 4.5 | — | 5.5 | V | |
| | Delta to V_{DD} ($V_{DD} - V_{DDA}$) ² | ΔV_{DDA} | -100 | 0 | 100 | mV | |
| Ground voltage | Delta to V_{SS} ($V_{SS} - V_{SSA}$) ² | ΔV_{SSA} | -100 | 0 | 100 | mV | |
| Input voltage | — | V_{ADIN} | V_{REFL} | — | V_{REFH} | V | |
| Input capacitance | — | C_{ADIN} | — | 4.5 | 5.5 | pF | |
| Input resistance | — | R_{ADIN} | — | 3 | 5 | k Ω | |
| Analog source resistance | 8-bit mode (all valid f_{ADCK}) | R_{AS} | — | — | 10 | k Ω | External to MCU |
| ADC conversion clock frequency | High speed (ADLPC = 0) | f_{ADCK} | 0.4 | — | 8.0 | MHz | |
| | Low power (ADLPC = 1) | | 0.4 | — | 4.0 | | |

¹ Typical values assume $V_{DDA} = 5.0$ V, Temp = 25 °C, $f_{ADCK} = 1.0$ MHz unless otherwise stated. Typical values are for reference only and are not tested in production.

² DC potential difference.

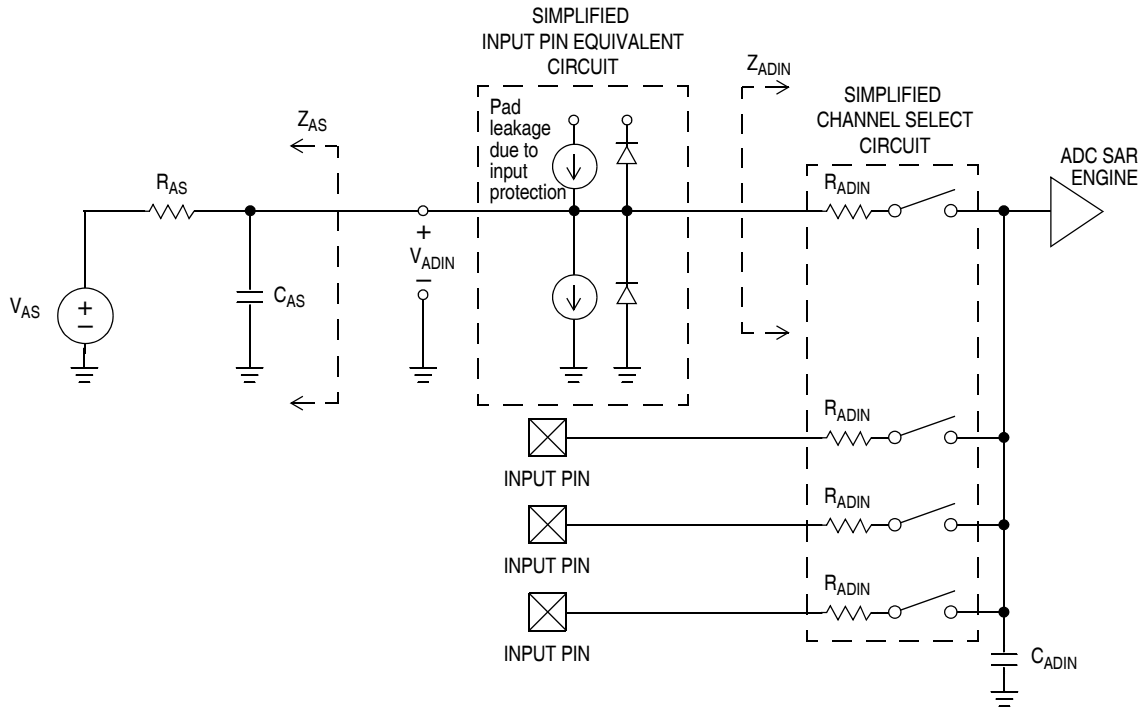

Figure 16. ADC Input Impedance Equivalency Diagram

Table 13. 8-Bit ADC Characteristics ($V_{REFH} = V_{DDA}$, $V_{REFL} = V_{SSA}$)

| C | Characteristic | Conditions | Symb | Min | Typ ¹ | Max | Unit | Comment |
|---|---|---------------------------|--------------|------|------------------|------|------------------|---|
| T | Supply Current ADLPC=1 ADLSMP=1 ADCO=1 | | I_{DDA} | — | 133 | — | μA | |
| T | Supply Current ADLPC=1 ADLSMP=0 ADCO=1 | | I_{DDA} | — | 218 | — | μA | |
| T | Supply Current ADLPC=0 ADLSMP=1 ADCO=1 | | I_{DDA} | — | 327 | — | μA | |
| P | Supply Current ADLPC=0 ADLSMP=0 ADCO=1 | | I_{DDA} | — | 0.582 | 1 | mA | |
| C | Supply Current | Stop, Reset, Module Off | I_{DDA} | — | 0.011 | 1 | μA | |
| P | ADC Asynchronous Clock Source | High Speed (ADLPC = 0) | f_{ADACK} | 2 | 3.3 | 5 | MHz | $t_{ADACK} = 1/f_{ADACK}$ |
| | | Low Power (ADLPC = 1) | | 1.25 | 2 | 3.3 | | |
| P | Conversion Time (Including sample time) | Short Sample (ADLSMP = 0) | t_{ADC} | — | 20 | — | ADCK cycles | See reference manual for conversion time variances |
| | | Long Sample (ADLSMP = 1) | | — | 40 | — | | |
| P | Sample Time | Short Sample (ADLSMP = 0) | t_{ADS} | — | 3.5 | — | ADCK cycles | |
| | | Long Sample (ADLSMP = 1) | | — | 23.5 | — | | |
| D | Temp Sensor Slope | −40°C– 25°C | m | — | 3.266 | — | mV/°C | |
| | | 25°C– 125°C | | — | 3.638 | — | | |
| D | Temp Sensor Voltage | 25 °C | V_{TEMP25} | — | 1.396 | — | mV | |
| P | Total Unadjusted Error | 8-bit mode | E_{TUE} | — | ±0.5 | ±1.0 | LSB ² | Includes quantization |
| P | Differential Non-Linearity | 8-bit mode ³ | DNL | — | ±0.3 | ±0.5 | LSB ² | |
| T | Integral Non-Linearity | 8-bit mode | INL | — | ±0.3 | ±0.5 | LSB ² | |
| P | Zero-Scale Error | 8-bit mode | E_{ZS} | — | ±0.5 | ±0.5 | LSB ² | $V_{ADIN} = V_{SSA}$ |
| T | Full-Scale Error | 8-bit mode | E_{FS} | — | ±0.5 | ±0.5 | LSB ² | $V_{ADIN} = V_{DDA}$ |

Table 13. 8-Bit ADC Characteristics ($V_{REFH} = V_{DDA}$, $V_{REFL} = V_{SSA}$) (continued)

| C | Characteristic | Conditions | Symb | Min | Typ ¹ | Max | Unit | Comment |
|---|---------------------|------------|----------|-----|------------------|-----------|------------------|--|
| D | Quantization Error | 8-bit mode | E_Q | — | — | ± 0.5 | LSB ² | |
| D | Input Leakage Error | 8-bit mode | E_{IL} | — | ± 0.1 | ± 1 | LSB ² | Pad leakage ² * R_{AS} |

¹ Typical values assume $V_{DDA} = 5.0$ V, Temp = 25 °C, $f_{ADCK} = 1.0$ MHz unless otherwise stated. Typical values are for reference only and are not tested in production.

² Based on input pad leakage current. Refer to pad electricals.

5.11 Flash Specifications

This section provides details about program/erase times and program-erase endurance for the flash memory.

Program and erase operations do not require any special power sources other than the normal V_{DD} supply. For more detailed information about program/erase operations, see the Memory section.

Table 14. Flash Characteristics

| C | Characteristic | Symbol | Min | Typical | Max | Unit |
|---|---|------------------|--------|---------|------|------------|
| D | Supply voltage for program/erase -40 °C to 85 °C | $V_{prog/erase}$ | 4.5 | — | 5.5 | V |
| D | Supply voltage for read operation | V_{Read} | 4.5 | — | 5.5 | V |
| D | Internal FCLK frequency ¹ | f_{FCLK} | 150 | — | 200 | kHz |
| D | Internal FCLK period (1/FCLK) | t_{FcyC} | 5 | — | 6.67 | μs |
| P | Byte program time (random location) ² | t_{prog} | 9 | | | t_{FcyC} |
| P | Byte program time (burst mode) ² | t_{Burst} | 4 | | | t_{FcyC} |
| P | Page erase time ² | t_{Page} | 4000 | | | t_{FcyC} |
| P | Mass erase time ² | t_{Mass} | 20,000 | | | t_{FcyC} |
| | Byte program current ³ | R_{IDDBP} | — | 4 | — | mA |
| | Page erase current ³ | R_{IDDPE} | — | 6 | — | mA |
| C | Program/erase endurance ⁴ T_L to $T_H = -40$ °C to 85 °C $T = 25$ °C | | — | 10,000 | — | cycles |
| C | Data retention ⁵ | t_{D_ret} | 5 | 100 | — | years |

¹ The frequency of this clock is controlled by a software setting.

² These values are hardware state machine controlled. User code does not need to count cycles. This information supplied for calculating approximate time to program and erase.

³ The program and erase currents are additional to the standard run I_{DD} . These values are measured at room temperatures with $V_{DD} = 5.0$ V, bus frequency = 4.0 MHz.

⁴ **Typical endurance for flash** was evaluated for this product family on the 9S12Dx64. For additional information on how Freescale defines typical endurance, please refer to Engineering Bulletin EB619, *Typical Endurance for Nonvolatile Memory*.

⁵ **Typical data retention** values are based on intrinsic capability of the technology measured at high temperature and de-rated to 25°C using the Arrhenius equation. For additional information on how Freescale defines typical data retention, please refer to Engineering Bulletin EB618, *Typical Data Retention for Nonvolatile Memory*.

5.12 EMC Performance

Electromagnetic compatibility (EMC) performance is highly dependant on the environment in which the MCU resides. Board design and layout, circuit topology choices, location and characteristics of external components as well as MCU software operation all play a significant role in EMC performance. The system designer should consult Freescale applications notes such as AN2321, AN1050, AN1263, AN2764, and AN1259 for advice and guidance specifically targeted at optimizing EMC performance.

5.12.1 Radiated Emissions

Microcontroller radiated RF emissions are measured from 150 kHz to 1 GHz using the TEM/GTEM Cell method in accordance with the IEC 61967-2 and SAE J1752/3 standards. The measurement is performed with the microcontroller installed on a custom EMC evaluation board while running specialized EMC test software. The radiated emissions from the microcontroller are measured in a TEM cell in two package orientations (the North and East).

The maximum radiated RF emissions of the tested configuration in all orientations are less than or equal to the reported emissions levels.

Table 15. Radiated Emissions, Electric Field

| Parameter | Symbol | Conditions | Frequency | f _{osc} /f _{bus} | Level ¹ (Max) | Unit | |
|------------------------------------|---------------------|--|----------------|------------------------------------|--------------------------|------|---|
| Radiated emissions, electric field | V _{RE_TEM} | V _{DD} = 5.0 V T _A = 25 °C package type 32-pin LQFP | 0.15 – 50 MHz | 4 MHz crystal 19 MHz bus | 9 | dBμV | |
| | | | 50 – 150 MHz | | 5 | | |
| | | | 150 – 500 MHz | | 2 | | |
| | | | 500 – 1000 MHz | | 1 | | |
| | | | IEC Level | | N | | — |
| | | | SAE Level | | 1 | | — |

¹ Data based on qualification test results.

6 Ordering Information

This section contains ordering information for MC9S08FL16 series devices. See below for an example of the device numbering system.

Table 16. Device Numbering System

| Device Number ¹ | Memory | | Available Packages ² |
|----------------------------|--------|------|---------------------------------|
| | FLASH | RAM | |
| MC9S08FL16 | 16 KB | 1024 | 32 SDIP |
| MC9S08FL8 | 8 KB | 768 | 32 LQFP |

Package Information

- ¹ See the reference manual, *MC9S08FL16 Series Reference Manual*, for a complete description of modules included on each device.
- ² See [Table 17](#) for package information.

Example of the device numbering system:

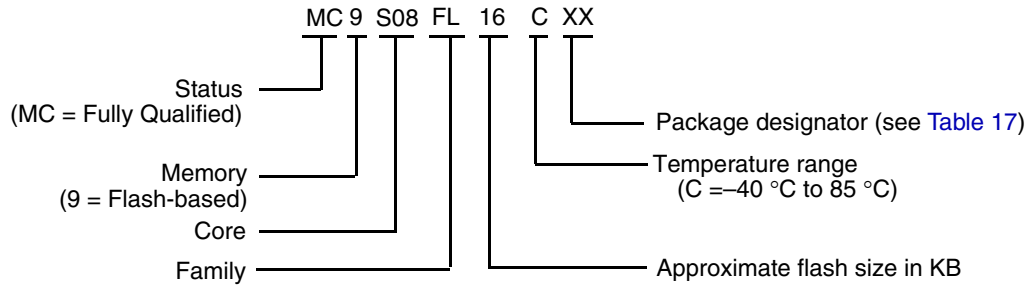

7 Package Information

Table 17. Package Descriptions

| Pin Count | Package Type | Abbreviation | Designator | Case No. | Document No. |
|-----------|-----------------------------|--------------|------------|----------|--------------|
| 32 | Low Quad Flat Package | LQFP | LC | 873A-03 | 98ASH70029A |
| 32 | Shrink Dual In-line Package | SDIP | BM | 1376-02 | 98ASA99330D |

7.1 Mechanical Drawings

The following pages are mechanical drawings for the packages described in [Table 17](#).

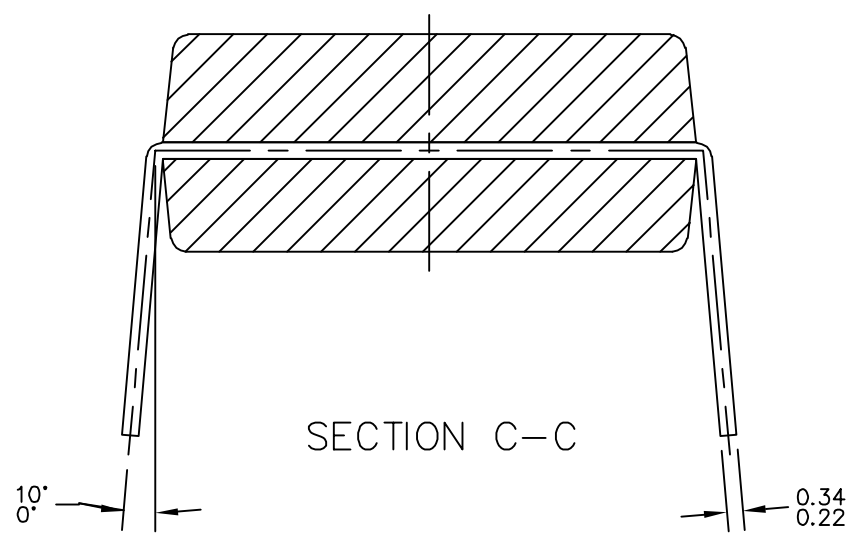
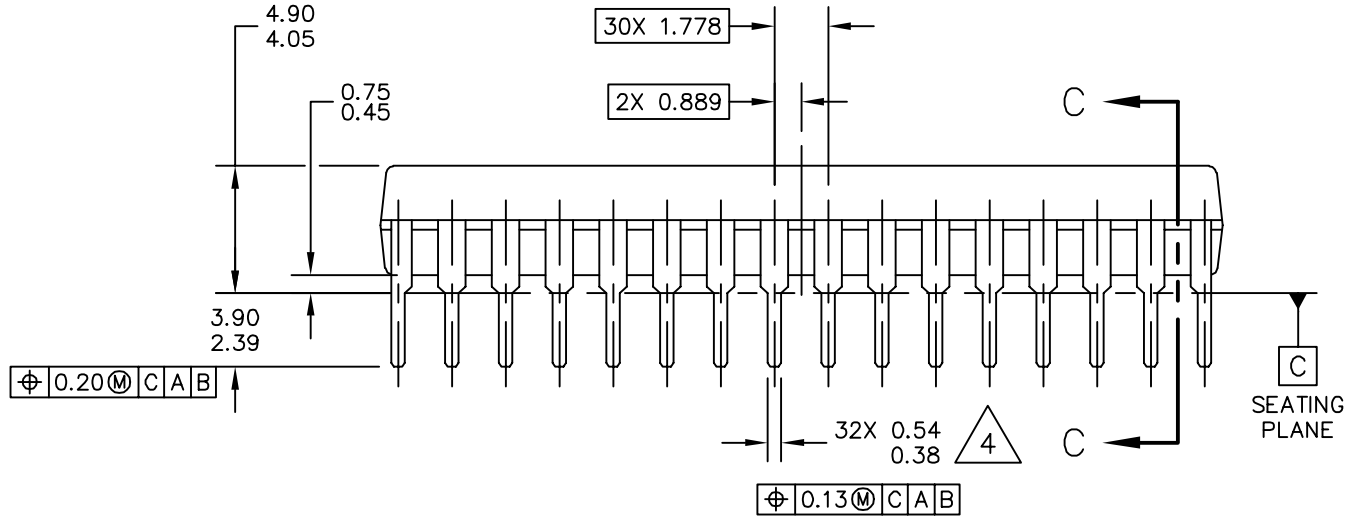
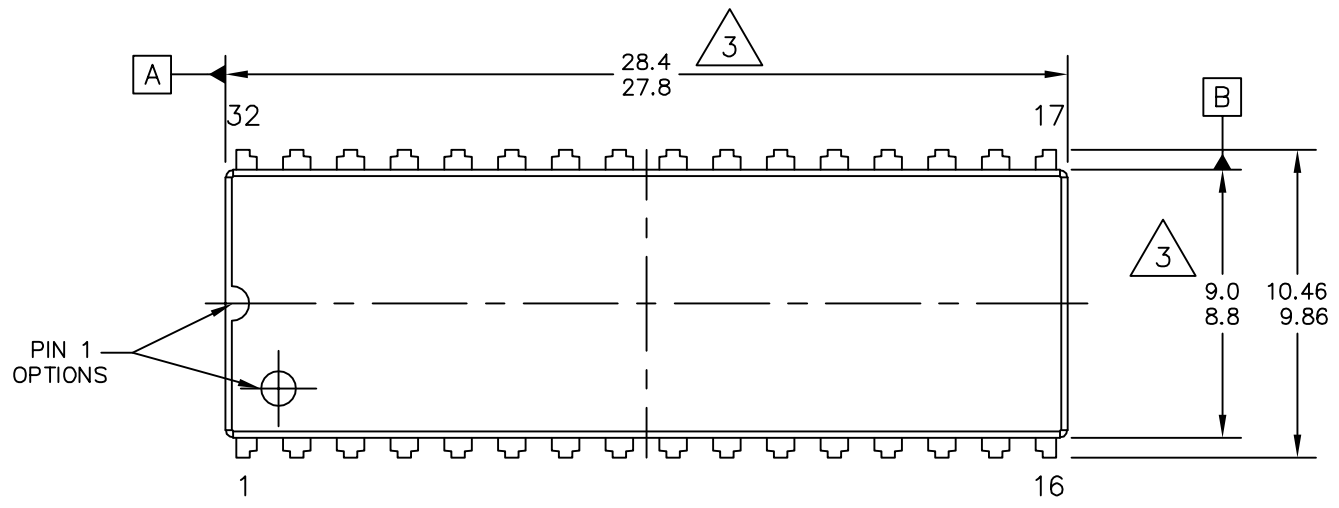

| | | | |
|---|---------------------------|----------------------------|--|
| © FREESCALE SEMICONDUCTOR, INC. ALL RIGHTS RESERVED. | MECHANICAL OUTLINE | PRINT VERSION NOT TO SCALE | |
| TITLE: 32 LEAD PDIP | DOCUMENT NO: 98ASA99330D | REV: A | |
| | CASE NUMBER: 1376-02 | 25 APR 2005 | |
| | STANDARD: NON-JEDEC | | |



NOTES:

1. ALL DIMENSION ARE IN MILLIMETERS.
2. INTERPRET DIMENSIONS AND TOLERANCES PER ASME Y14.5-1994.
3. DIMENSIONS DO NOT INCLUDE MOLD FLASH OR PROTRUSIONS.
4. DIMENSION DOES NOT INCLUDE DAMBAR PROTRUSION.

| | | | |
|---|---------------------------|----------------------------|--|
| © FREESCALE SEMICONDUCTOR, INC. ALL RIGHTS RESERVED. | MECHANICAL OUTLINE | PRINT VERSION NOT TO SCALE | |
| TITLE: 32 LEAD PDIP | DOCUMENT NO: 98ASA99330D | REV: A | |
| | CASE NUMBER: 1376-02 | 25 APR 2005 | |
| | STANDARD: NON-JEDEC | | |

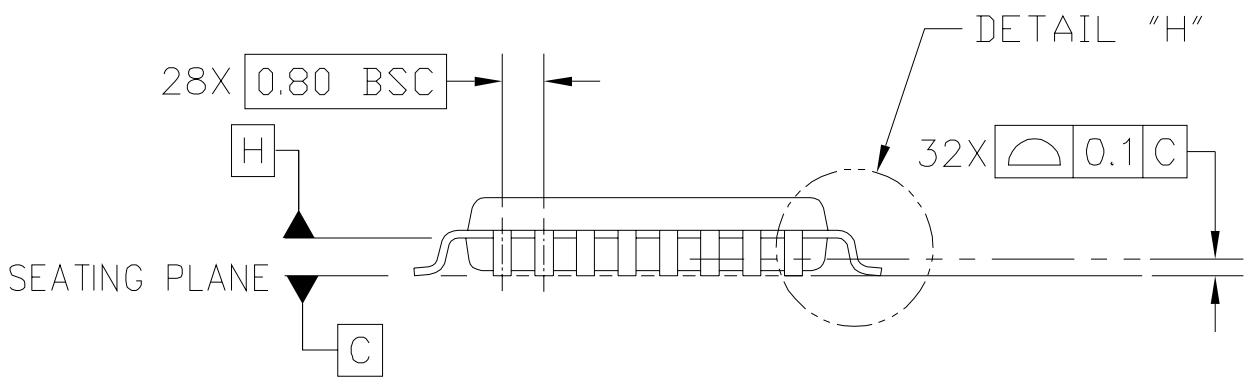
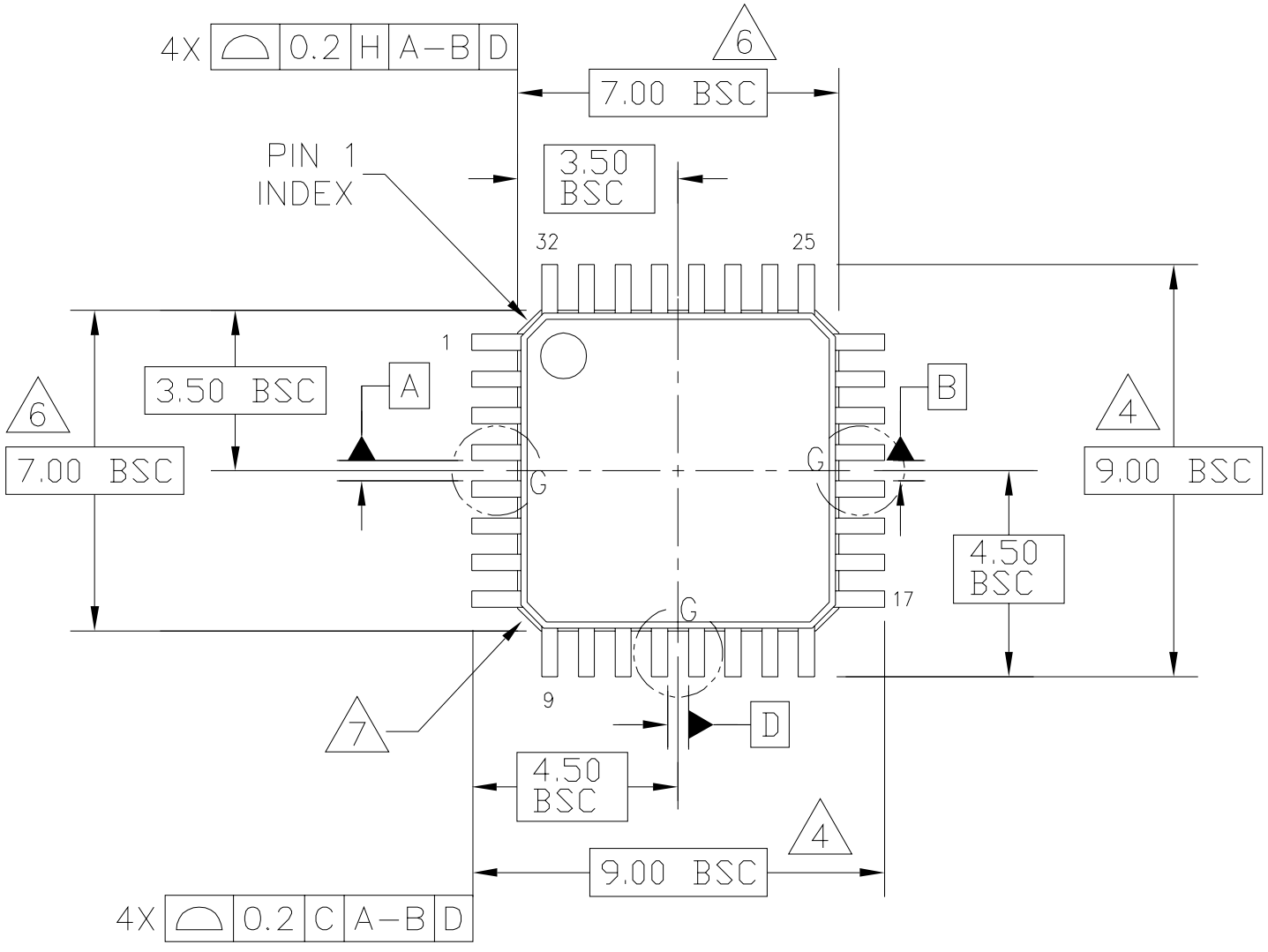

| | | | |
|---|----------------------------|----------------------------|--|
| © FREESCALE SEMICONDUCTOR, INC. ALL RIGHTS RESERVED. | MECHANICAL OUTLINE | PRINT VERSION NOT TO SCALE | |
| TITLE: LOW PROFILE QUAD FLAT PACK (LQFP) 32 LEAD, 0.8 PITCH (7 X 7 X 1.4) | DOCUMENT NO: 98ASH70029A | REV: D | |
| | CASE NUMBER: 873A-03 | 19 MAY 2005 | |
| | STANDARD: JEDEC MS-026 BBA | | |



NOTES:

1. DIMENSIONS ARE IN MILLIMETERS.

2. INTERPRET DIMENSIONS AND TOLERANCES PER ASME Y14.5-1994.

3. DATUMS A, B, AND D TO BE DETERMINED AT DATUM PLANE H.

4. DIMENSIONS TO BE DETERMINED AT SEATING PLANE DATUM C.

5. DIMENSION DOES NOT INCLUDE DAMBAR PROTRUSION. ALLOWABLE DAMBAR PROTRUSION SHALL NOT CAUSE THE LEAD WIDTH TO EXCEED THE MAXIMUM DIMENSION BY MORE THAN 0.08 MM. DAMBAR CANNOT BE LOCATED ON THE LOWER RADIUS OR THE FOOT. MINIMUM SPACE BETWEEN PROTRUSION AND ADJACENT LEAD OR PROTRUSION: 0.07 MM.

6. DIMENSIONS DO NOT INCLUDE MOLD PROTRUSION. ALLOWABLE PROTRUSION IS 0.25 MM PER SIDE. DIMENSIONS ARE MAXIMUM PLASTIC BODY SIZE DIMENSIONS INCLUDING MOLD MISMATCH.

7. EXACT SHAPE OF EACH CORNER IS OPTIONAL.

8. THESE DIMENSIONS APPLY TO THE FLAT SECTION OF THE LEAD BETWEEN 0.1 MM AND 0.25 MM FROM THE LEAD TIP.

| | | | |
|---|----------------------------|----------------------------|--|
| © FREESCALE SEMICONDUCTOR, INC. ALL RIGHTS RESERVED. | MECHANICAL OUTLINE | PRINT VERSION NOT TO SCALE | |
| TITLE: LOW PROFILE QUAD FLAT PACK (LQFP) 32 LEAD, 0.8 PITCH (7 X 7 X 1.4) | DOCUMENT NO: 98ASH70029A | REV: D | |
| | CASE NUMBER: 873A-03 | 19 MAY 2005 | |
| | STANDARD: JEDEC MS-026 BBA | | |

How to Reach Us:

Home Page:

www.freescale.com

Web Support:

<http://www.freescale.com/support>

USA/Europe or Locations Not Listed:

Freescale Semiconductor, Inc.
Technical Information Center, EL516
2100 East Elliot Road
Tempe, Arizona 85284
1-800-521-6274 or +1-480-768-2130
www.freescale.com/support

Europe, Middle East, and Africa:

Freescale Halbleiter Deutschland GmbH
Technical Information Center
Schatzbogen 7
81829 Muenchen, Germany
+44 1296 380 456 (English)
+46 8 52200080 (English)
+49 89 92103 559 (German)
+33 1 69 35 48 48 (French)
www.freescale.com/support

Japan:

Freescale Semiconductor Japan Ltd.
Headquarters
ARCO Tower 15F
1-8-1, Shimo-Meguro, Meguro-ku,
Tokyo 153-0064
Japan
0120 191014 or +81 3 5437 9125
support.japan@freescale.com

Asia/Pacific:

Freescale Semiconductor China Ltd.
Exchange Building 23F
No. 118 Jianguo Road
Chaoyang District
Beijing 100022
China
+86 10 5879 8000
support.asia@freescale.com

For Literature Requests Only:

Freescale Semiconductor Literature Distribution Center
P.O. Box 5405
Denver, Colorado 80217
1-800-441-2447 or +1-303-675-2140
Fax: +1-303-675-2150
LDCForFreescaleSemiconductor@hibbertgroup.com

Information in this document is provided solely to enable system and software implementers to use Freescale Semiconductor products. There are no express or implied copyright licenses granted hereunder to design or fabricate any integrated circuits or integrated circuits based on the information in this document.

Freescale Semiconductor reserves the right to make changes without further notice to any products herein. Freescale Semiconductor makes no warranty, representation or guarantee regarding the suitability of its products for any particular purpose, nor does Freescale Semiconductor assume any liability arising out of the application or use of any product or circuit, and specifically disclaims any and all liability, including without limitation consequential or incidental damages. "Typical" parameters that may be provided in Freescale Semiconductor data sheets and/or specifications can and do vary in different applications and actual performance may vary over time. All operating parameters, including "Typicals", must be validated for each customer application by customer's technical experts. Freescale Semiconductor does not convey any license under its patent rights nor the rights of others. Freescale Semiconductor products are not designed, intended, or authorized for use as components in systems intended for surgical implant into the body, or other applications intended to support or sustain life, or for any other application in which the failure of the Freescale Semiconductor product could create a situation where personal injury or death may occur. Should Buyer purchase or use Freescale Semiconductor products for any such unintended or unauthorized application, Buyer shall indemnify and hold Freescale Semiconductor and its officers, employees, subsidiaries, affiliates, and distributors harmless against all claims, costs, damages, and expenses, and reasonable attorney fees arising out of, directly or indirectly, any claim of personal injury or death associated with such unintended or unauthorized use, even if such claim alleges that Freescale Semiconductor was negligent regarding the design or manufacture of the part.



Freescale™ and the Freescale logo are trademarks of Freescale Semiconductor, Inc. All other product or service names are the property of their respective owners.

© Freescale Semiconductor, Inc. 2009. All rights reserved.