

# TFA9871

## High Efficiency Class-D Audio Amplifier

Rev. 1 — 14 August 2018

Product data sheet

## 1 General description

The TFA9871 is a high efficiency 8.5 V boosted class-D audio amplifier. It can deliver up to 8 W peak output power into an 8  $\Omega$  speaker and up to 10 W peak output power into a 6  $\Omega$  speaker, at a supply voltage of 4.0 V. The internal adaptive DC-to-DC converter raises the supply voltage up to 8.5 V, providing ample headroom for major improvements in sound quality.

Internal adaptive DC-to-DC conversion boosts the supply rail to provide additional headroom and power output. The supply voltage is only raised when necessary. This maximizes the output power of the class-D audio amplifier while limiting quiescent power consumption.

The device can be configured to drive either a hands-free speaker (4  $\Omega$  to 8  $\Omega$ ) for audio playback, or a receiver speaker (32  $\Omega$ ), for handset playback, allowing it to be embedded in platforms supporting both a hands-free speaker and a handset speaker. The maximum output power and the noise levels are lower in handset call use case than in hands-free call use case.

The TFA9871 also incorporates battery protection. By limiting the supply current when the battery voltage is low, it prevents the audio system from drawing excessive load currents from the battery, which could cause a system under voltage. This circuitry minimizes the impact of a falling battery voltage by preventing unexpected device switch off due to excessive current drawn from the battery.

The device features low RF susceptibility because it has a digital input interface that is insensitive to clock jitter. The second order closed loop architecture used in a class-D audio amplifier provides excellent audio performance and high supply voltage ripple rejection. The audio input interface is TDM and the control settings are communicated via an I<sup>2</sup>C-bus interface.

The TFA9871 is available in a 36-bump WLCSP (Wafer Level Chip-Size Package) with a 400  $\mu\text{m}$  pitch.

## 2 Features and benefits

- High output power: 4.1 W (average) into 8  $\Omega$  at 4.0 V supply voltage (THD = 1 %)
- Supports handset (16  $\Omega$  or 32  $\Omega$ ) and hands-free (4  $\Omega$  to 8  $\Omega$ ) speaker configurations
- High efficiency, low power dissipation and low-noise speaker driver
- Adaptive DC-to-DC converter increases the supply voltage smoothly when switching between Fixed Boost and Adaptive Boost modes, preventing large battery supply spikes and limiting quiescent power consumption
- Wide supply voltage range (fully operational from 2.7 V to 5.5 V)
- Very low noise output voltage <15  $\mu\text{V}$  with -60 dBFS input at  $f_s = 48$  kHz)
- Low battery current consumption <118 mA ( $P_o = 380$  mW, average music power)
- I<sup>2</sup>C-bus control interface (400 kHz)



- Speaker current and voltage monitoring (via the TDM-bus) for Acoustic Echo Cancellation (AEC) at the host
- 16 kHz/32 kHz/44.1 kHz/48 kHz sample frequencies supported
- Ultrasonic support via TDM running at 96 kHz
- Programmable interrupt control via a dedicated interrupt pin
- Low RF susceptibility
- Thermal foldback and overtemperature protection
- 15 kV system-level ESD protection without external components on amplifier output

### 3 Applications

- Mobile phones and Tablets
- Portable Navigation Devices (PND)
- Notebooks/Netbooks
- Internet of Things applications embedding high quality audio

### 4 Quick reference data

Table 1. Quick reference data

Symbol	Parameter	Conditions	Min	Typ	Max	Unit
V <sub>BAT</sub>	battery supply voltage	on pin VBAT V <sub>BAT</sub> must not be lower than V <sub>DDD</sub> in application	2.7	-	5.5	V
V <sub>DDD</sub>	digital supply voltage	on pin VDDD	1.65	1.8	1.95	V
V <sub>DDP</sub>	power supply voltage	on pin VDDP	2.7	-	8.5	V
R <sub>L</sub>	load resistance		3.2	-	38	Ω
I <sub>BAT</sub>	battery supply current	Active state on pin VBAT; Operating mode with load R <sub>L</sub> = 6 Ω; DC-to-DC in Adaptive Boost mode; P <sub>o</sub> = 380 mW, (average music power), V <sub>BAT</sub> = 4.0 V; V <sub>DDP</sub> = 8.5 V	-	120	-	mA
		Idle state on pin VBAT; Operating mode with load R <sub>L</sub> = 6 Ω; DC-to-DC in Adaptive Boost mode; P <sub>o</sub> = 0 mW; V <sub>BAT</sub> = 4.0 V; V <sub>DDP</sub> = 8.5 V	-	2.5	-	mA
		Power-down state	-	1	-	μA

Symbol	Parameter	Conditions	Min	Typ	Max	Unit
I <sub>DDD</sub>	digital supply current	Active state on pin VDDD; Operating mode with load R <sub>L</sub> = 6 Ω; DC-to-DC in Adaptive Boost mode; P <sub>o</sub> = 380 mW, (average music power), V <sub>BAT</sub> = 4.0 V; V <sub>DDP</sub> = 8.5 V	-	5.2	-	mA
		Idle state on pin VDDD; Operating mode with load R <sub>L</sub> = 6 Ω; DC-to-DC in Adaptive Boost mode; P <sub>o</sub> = 0 mW; V <sub>BAT</sub> = 4.0 V; V <sub>DDP</sub> = 8.5 V	-	3.6	-	mA
		Power-down state	-	10	-	μA
P <sub>o(AV)</sub>	average output power	THD+N = 1 %; (R <sub>L</sub> = 8 Ω; L <sub>L</sub> = 44 μH); V <sub>BST</sub> = 8.5 V; V <sub>BAT</sub> = 4.0 V; V <sub>DDD</sub> = 1.8 V	-	4.1	-	W
		THD+N = 1 %; (R <sub>L</sub> = 6 Ω; L <sub>L</sub> = 44 μH); V <sub>BST</sub> = 8.5 V; V <sub>BAT</sub> = 4.0 V; V <sub>DDD</sub> = 1.8 V	-	5.1	-	W

## 5 Ordering information

Table 2. Ordering information

Type number	Package		Version
	Name	Description	
TFA9871UK/N1	WLCSP36	wafer level chip-scale package; 36 bumps; 0.4 mm pitch, 2.62 mm × 2.51 mm × 0.5 mm;	SOT1780-5

### 6 Block diagram

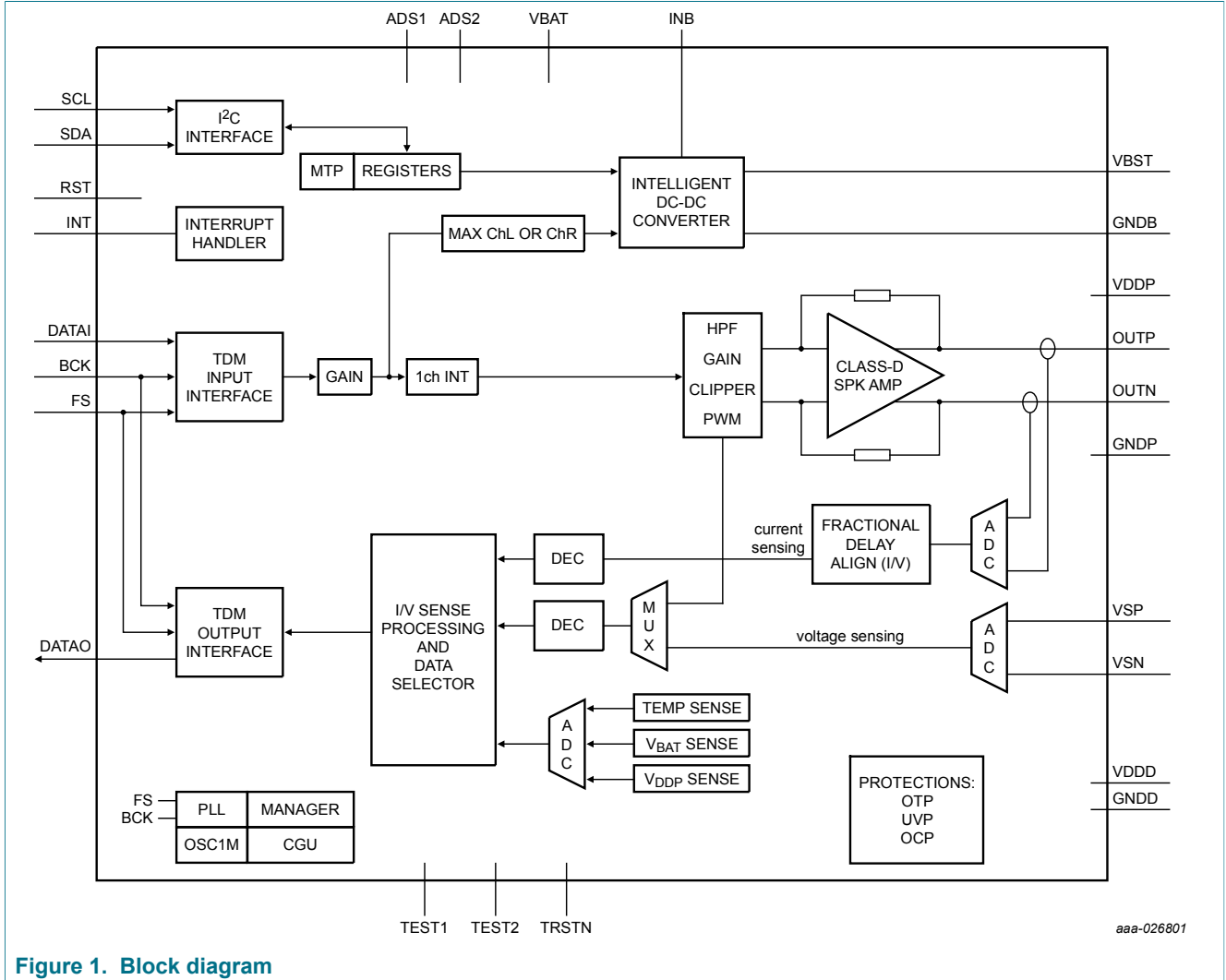
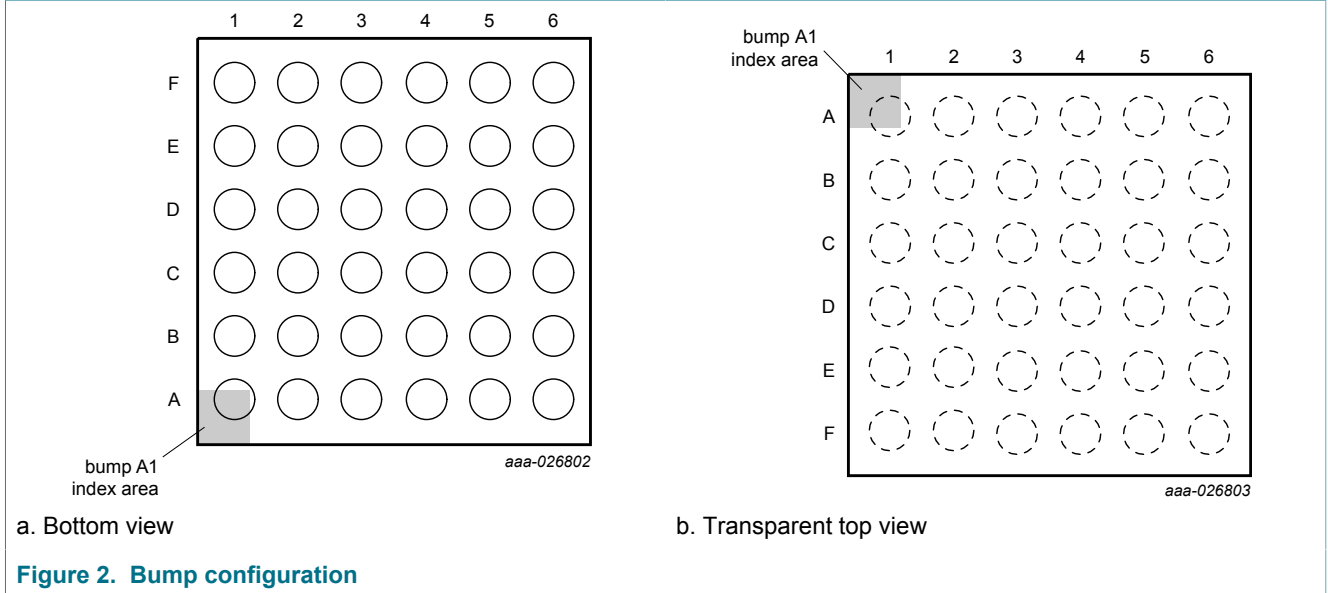

Figure 1. Block diagram

## 7 Pinning information

### 7.1 Pinning



	1	2	3	4	5	6
A	BCK	FS	VDDD	SCL	SDA	TRSTN
B	DATAO	DATAI	ADS2	ADS1	INT	VBAT
C	RST	GNDD	VSN	TEST2	TEST1	VSP
D	GNDB	GNDB	GNDB	GNDD	GNDP	GNDD
E	INB	INB	INB	OUTP	GNDP	OUTN
F	VBST	VBST	VBST	VDDP	VDDP	VDDP

aaa-030120

Transparent top view

**Figure 3. Bump mapping**

**Table 3. Pinning**

Symbol	Pin	Type	Description
BCK	A1	I	digital audio bit clock input for TDM interface
FS	A2	I	digital audio frame sync input for TDM interface
VDDD	A3	I	digital supply voltage
SCL	A4	I	digital I <sup>2</sup> C-bus clock input
SDA	A5	I/O	digital I <sup>2</sup> C-bus data input/output
TRSTN	A6	I	test signal input TRSTN, connect to PCB ground
DATAO	B1	I/O	digital audio data output for TDM interface
DATAI	B2	I	digital audio data input for TDM interface

Symbol	Pin	Type	Description
ADS2	B3	I	digital address select input 2
ADS1	B4	I	digital address select input 1
INT	B5	O	digital interrupt output
VBAT	B6	P	battery supply voltage
RST	C1	I	reset input
GNDD	C2	P	digital ground
VSN	C3	I/O	voltage sense negative input
TEST2	C4	I/O	test signal input 2; for test purposes only; connect to PCB ground, or connect via a capacitor to PCB ground
TEST1	C5	I/O	test signal input 1; for test purposes only; connect to PCB ground, or connect via a capacitor to PCB ground input
VSP	C6	I/O	voltage sense positive
GNDB	D1	P	boosted ground
GNDB	D2	P	boosted ground
GNDB	D3	P	boosted ground
GNDD	D4	P	digital ground
GNDP	D5	P	power ground
GNDD	D6	P	digital ground
INB	E1	P	DC-to-DC boost converter input
INB	E2	P	DC-to-DC boost converter input
INB	E3	P	DC-to-DC boost converter input
OUTP	E4	O	non-inverting output
GNDP	E5	P	power ground
OUTN	E6	O	inverting output
VBST	F1	O	boosted supply voltage output
VBST	F2	O	boosted supply voltage output
VBST	F3	O	boosted supply voltage output
VDDP	F4	P	power supply voltage
VDDP	F5	P	power supply voltage
VDDP	F6	P	power supply voltage

## 8 Functional description

---

The TFA9871 is a highly efficient Bridge Tied Load (BTL) class-D audio amplifier as depicted in block diagram (see [Figure 1](#)).

TFA9871 contains a TDM input/output interface for communicating with the audio host. It also offers the possibility of providing an ultrasonic path to the speaker.

At low battery voltage levels, the gain (from TDM interface to speaker output) is automatically reduced to limit battery current (when battery safeguard is enabled).

The digital audio stream is converted into two Pulse Width Modulated (PWM) signals which are then injected into the class-D audio amplifier. The 3-level PWM scheme supports filterless speaker drive.

An adaptive DC-to-DC converter boosts the output voltage to the level that is required by the ClassD amplifier.

## 9 Limiting values

**Table 4. Limiting values**

*In accordance with the Absolute Maximum Rating System (IEC 60134).*

Symbol	Parameter	Conditions	Min	Typ	Max	Unit
V <sub>BAT</sub>	battery supply voltage	on pin VBAT	-0.3	-	+6	V
V <sub>BST</sub>	booster output voltage	on pin VBST	-0.3	-	+12 <sup>[1]</sup>	V
V <sub>INB</sub>	booster input voltage	on pin INB	-0.3	-	+12 <sup>[1]</sup>	V
V <sub>DDP</sub>	power supply voltage	on pin VDDP	-0.3	-	+12 <sup>[1]</sup>	V
V <sub>O</sub>	output voltage	on speaker connections; pins OUTP, OUTN	-0.3	-	+12 <sup>[1]</sup>	V
V <sub>DDD</sub>	digital supply voltage	on pin VDDD	-0.3	-	+2.5	V
V <sub>low</sub>	low voltage	on pins TEST1/TEST2	-0.3	-	+2.5	V
T <sub>j</sub>	junction temperature		-	-	+125	°C
T <sub>stg</sub>	storage temperature		-55	-	+150	°C
T <sub>amb</sub>	ambient temperature		-40	-	+85	°C
V <sub>ESD</sub>	electrostatic discharge voltage	according to Human Body Model (HBM)	-2	-	+2	kV
		according to Charge Device Model (CDM)	-500	-	+500	V

[1] Using NXP demo board, with a 1 mm wire/PCB track length on INB pin, AC pulse up to 15 V can be observed, without damaging the device as these spikes do not end up inside the actual device.

## 10 Thermal characteristics

**Table 5. Thermal characteristics**

Symbol	Parameter	Conditions	Typ	Max	Unit
R <sub>th(j-a)</sub>	thermal resistance from junction to ambient	4-layer application board	40	-	K/W



## 11 Characteristics

### 11.1 DC Characteristics

**Table 6. DC characteristics**

All parameters are guaranteed for  $V_{BAT} = 4.0\text{ V}$ ;  $V_{DDD} = 1.8\text{ V}$ ;  $V_{DDP} = V_{BST} = 8.5\text{ V}$ , adaptive boost mode;  $L_{BST} = 1\ \mu\text{H}^{[1]}$ ;  $R_L = 8\ \Omega^{[1]}$ ;  $L_L = 44\ \mu\text{H}^{[1]}$ ;  $f_i = 1\text{ kHz}$ ;  $f_s = 48\text{ kHz}$ ;  $T_{amb} = 25\text{ }^\circ\text{C}$ ; default settings, unless otherwise specified.

Symbol	Parameter	Conditions	Min	Typ	Max	Unit
$V_{BAT}$	battery supply voltage	on pin VBAT $V_{BAT}$ must not be lower than $V_{DDD}$	2.7	-	5.5	V
$I_{BAT}$	battery supply current	Active state: On pin VBAT; Operating mode with load $R_L = 6\ \Omega$ ; DC-to-DC in Adaptive Boost mode; $P_o = 380\text{ mW}$ , (average music power),	-	120	-	mA
		Idle state: On pin VBAT; Operating mode with load $R_L = 6\ \Omega$ and no output signal (idle); DC-to-DC converter in Adaptive Boost mode;	-	2.5	-	mA
		Power-down state: On pin VBAT; DC-to-DC in Power-down mode; $T_j = 25\text{ }^\circ\text{C}$ ; no clock	-	1	-	$\mu\text{A}$
$V_{DDP}$	power supply voltage	on pin VDDP	2.7	-	8.5	V
$V_{DDD}$	digital supply voltage	on pin VDDD	1.65	1.8	1.95	V
$I_{DDD}$	digital supply current	Active state	-	5.2	-	mA
		Idle state	-	3.6	-	mA
		Power-down state	-	10	-	$\mu\text{A}$
<b>Pins FS, BCK, DATA1, ADS1, ADS2, SCL, SDA, RST, TRSTN</b>						
$V_{IH}$	HIGH-level input voltage		$0.7V_{DDD}$	-	$V_{DDD}$	V
$V_{IL}$	LOW-level input voltage		-	-	$0.3V_{DDD}$	V
$C_{in}$	input capacitance		[2]	-	3	pF
$I_{LI}$	input leakage current	1.8 V on input pin	-	-	0.1	$\mu\text{A}$
<b>Pins DATA0, INT, push-pull output stages</b>						
$V_{OH}$	HIGH-level output voltage	$I_{OH} = 4\text{ mA}$	$V_{DDD} - 0.4$	-	-	V
$V_{OL}$	LOW-level output voltage	$I_{OL} = 4\text{ mA}$	-	-	400	mV
<b>Pins SDA, open-drain outputs, external 10 k<math>\Omega</math> resistor to <math>V_{DDD}</math></b>						
$V_{OH}$	HIGH-level output voltage		$V_{DDD} - 0.4$	-	-	V
$V_{OL}$	LOW-level output voltage	$I_{OL} = 4\text{ mA}$	-	-	400	mV
<b>Pins OUTP, OUTN</b>						
$R_{DSon}$	drain-source on-state resistance	PMOS+NMOS transistors	-	430	520	m $\Omega$

Symbol	Parameter	Conditions	Min	Typ	Max	Unit
<b>Protection</b>						
T <sub>act(th_prot)</sub>	thermal protection activation temperature		130	-	-	°C
V <sub>ovp(VBAT)</sub>	overvoltage protection on pin VBAT		5.6	-	6.0	V
V <sub>uvp(VBAT)</sub>	undervoltage protection on pin VBAT		2.3	-	2.7	V
I <sub>O(ocp)</sub>	overcurrent protection output current		2.5	-	-	A
<b>DC-to-DC converter</b>						
V <sub>BST</sub>	voltage on pin VBST	DCVOS = 111111; Boost mode (after trim)	8.3	8.5	8.7	V

[1] L<sub>BST</sub> = boost converter inductance; R<sub>L</sub> = load resistance; L<sub>L</sub> = load inductance (speaker).

[2] This parameter is not tested during production; the value is guaranteed by design and checked during product validation.

## 11.2 AC characteristics

**Table 7. AC characteristics**

All parameters are guaranteed for V<sub>BAT</sub> = 4.0 V; V<sub>DDD</sub> = 1.8 V; V<sub>DDP</sub> = V<sub>BST</sub> = 8.5 V, adaptive boost mode; L<sub>BST</sub> = 1 μH<sup>[1]</sup>; R<sub>L</sub> = 8 Ω<sup>[1]</sup>; L<sub>L</sub> = 44 μH<sup>[1]</sup>; f<sub>i</sub> = 1 kHz; f<sub>s</sub> = 48 kHz; T<sub>amb</sub> = 25 °C; default settings, unless otherwise specified.

Symbol	Parameter	Conditions	Min	Typ	Max	Unit
<b>Amplifier output power</b>						
P <sub>o(AV)</sub>	average output power	Hands-free speaker, THD+N = 1 %				
		R <sub>L</sub> = 8 Ω; f <sub>s</sub> = 48 kHz	3.6	4.1	-	W
		R <sub>L</sub> = 6 Ω; f <sub>s</sub> = 48 kHz	4.6	5.1	-	W
		R <sub>L</sub> = 4 Ω; f <sub>s</sub> = 48 kHz	5.1	5.7	-	W
		Receiver speaker. THD+N = 1 %;				
		R <sub>L</sub> = 32 Ω; Voice mode	-	0.2	-	W
R <sub>L</sub> = 32 Ω; Audio mode	-	1.1	-	W		
<b>Amplifier output pins (OUTP and OUTN)</b>						
V <sub>O(offset)</sub>	output offset voltage	absolute value, after trimming; V <sub>DDP</sub> = 3.4 V to 8.5 V, V <sub>BAT</sub> = 3.4 V to 5 V	-	-	1.0	mV

Symbol	Parameter	Conditions	Min	Typ	Max	Unit	
<b>Amplifier performances</b>							
$\eta_{po}$	output power efficiency	On pin VBAT; Operating mode with load $R_L = 6 \Omega$ ; DC-to-DC in Tracking Boost mode, $P_o = 380$ mW, (average music power)	[2]	-	82	-	%
		On pin VBAT; input: 100 Hz sine wave, $R_L = 8 \Omega$ ; DC-to-DC in Tracking Boost mode, $P_o = 600$ mW	[2]	-	91	-	%
		On pin V <sub>BAT</sub> ; Input: 100 Hz sine wave, $R_L = 8 \Omega$ ; DC-to-DC in Adaptive Boost mode, $P_o = 3$ W	[2]	-	84	-	%
THD+N	total harmonic distortion-plus-noise	$P_o = 2.0$ W, $R_L = 8 \Omega$	[1]	-	-	0.05	%
		$P_o = 2.0$ W, $R_L = 4 \Omega$	[1]	-	-	0.09	%
$V_{n(o)}$	output noise voltage	A-weighted; no input signal; Low Noise mode $f_s = 48$ kHz	[2]	-	13	16	$\mu$ V
		A-weighted; no input signal; Low Noise mode; $f_s = 16$ kHz, 32 kHz	[2]	-	-	50	$\mu$ V
		A-weighted; no input signal; Low Noise mode; $f_s = 44.1$ kHz	[2]	-	15	18	$\mu$ V
DR	dynamic range	A-weighted, $V_{BAT} = 3.4$ V to 5 V, S/N = maximum signal (at THD = 1 %); output noise voltage ( $V_{n(o)}$ ); No signal applied	[2]	108	112	-	dB
S/N	signal-to-noise ratio	A-weighted, $V_{BAT} = 3.4$ V to 5 V, maximum signal at THD = 1 %	[2]	100	-	-	dB
PSRR	power supply rejection ratio	from $V_{BAT}$ ; booster in follower mode ( $V_{DDP} = V_{BAT}$ ) $f_{ripple} = 217$ Hz square wave, $V_{ripple} = 50$ mV <sub>(p-p)</sub>		60	80	-	dB
		from $V_{BAT}$ ; booster in follower mode ( $V_{DDP} = V_{BAT}$ ) $f_{ripple} = 20$ Hz to 1 kHz sine wave, $V_{ripple} = 200$ mV (RMS), $V_{BAT} = 3.4$ V to 5.0 V Low Power AND Low Noise modes on		60	80	-	dB
		from $V_{BAT}$ ; booster in follower mode ( $V_{DDP} = V_{BAT}$ ) $f_{ripple} = 1$ kHz to 20 kHz sine wave, $V_{ripple} = 200$ mV (RMS), $V_{BAT} = 3.4$ V to 5.0 V		55	70	-	dB
$\Delta G/\Delta f$	gain variation with frequency	BW = 20 Hz to 15 kHz, $V_{BAT} = 3.4$ V to 5 V		-0.1	-	0.7	dB
$V_{POP}$	pop noise voltage	At mode transition and gain change.		-	-	2	mV
$R_L$	load resistance			3.2	8	38	$\Omega$
$C_L$	load capacitance			-	-	200	pF

Symbol	Parameter	Conditions	Min	Typ	Max	Unit
$f_{sw}$	switching frequency	directly coupled to the TDM input frequency	256	-	384	kHz
$G_{(TDM-VO)}$	TDM to $V_O$ gain	INPLEV = 0 dB	6	-	21	dB
<b>Amplifier power-up, power-down and propagation delays</b>						
$t_{d(PLL)}$	PLL turn-on delay time	PLL locked on BCK, $f_s = 48$ kHz	-	2	-	ms
$t_{d(amp)}$	amplifier turn-on delay time	$f_s = 48$ kHz	-	1	-	ms
$t_{d(off)}$	turn-off delay time		-	32	-	$\mu$ s
$t_{d(alarm)}$	alarm delay time		-	200	-	ms
$t_{PD}$	propagation delay	$f_s = 16$ kHz	-	-	850	$\mu$ s
		$f_s = 32$ kHz	-	-	750	$\mu$ s
		$f_s = 44.1$ kHz	-	-	650	$\mu$ s
		$f_s = 48$ kHz	-	-	700	$\mu$ s
<b>Booster Inductance</b>						
$L_{bst}$	boost inductance		0.7	1.0	2.2	$\mu$ H
<b>Current-sensing performance</b>						
$L_{L(spk)}$	speaker load inductance		30	-	-	$\mu$ H
S/N	signal-to-noise ratio	$I_O = 1.1$ A (peak); A-weighted	62	65	-	dB
$\Delta V_{sense}/I_{sense}$	$V_{sense}/I_{sense}$ ratio mismatch	Pilot tone -40 dBFS	[3]	2	-	%
THD+N	total harmonic distortion-plus-noise	$f_i = 20$ Hz to 20 kHz, $V_i = -12$ dBFS	-	-	0.75	%

[1]  $L_{BST}$  = boost converter inductor;  $R_L$  = load resistance;  $L_L$  = load inductance (speaker).

[2] This parameter is not tested during production; the value is guaranteed by design and checked during product validation.

[3] Intended for Speaker protection. In combination with NXP speaker protection a speaker temperature accuracy of +/- 10 °C can be realized

### 11.3 TDM timing characteristics

**Table 8. TDM bus interface characteristics**

All parameters are guaranteed for  $V_{BAT} = 4.0\text{ V}$ ;  $V_{DDD} = 1.8\text{ V}$ ;  $V_{DDP} = V_{BST} = 8.5\text{ V}$ , adaptive boost mode;  $L_{BST} = 1\text{ }\mu\text{H}^{[1]}$ ;  $R_L = 8\text{ }\Omega^{[1]}$ ;  $L_L = 44\text{ }\mu\text{H}^{[1]}$ ;  $f_i = 1\text{ kHz}$ ;  $f_s = 48\text{ kHz}$ ;  $T_{amb} = 25\text{ }^\circ\text{C}$ ; default settings, unless otherwise specified.

Symbol	Parameter	Conditions	Min	Typ	Max	Unit
$f_s$	sampling frequency	on pin WS, audio mode	[2] 16	-	48	kHz
		on pin WS, ultrasonic mode	-	-	96	kHz
$f_{clk}$	clock frequency	on pin BCK, audio mode	[2] $32f_s$	-	$384f_s$	kHz
		on pin BCK, ultrasonic mode	-	-	$96f_s$	MHz
$t_{su}$	set-up time	WS edge to BCK HIGH	[3] 10	-	-	ns
		DATA edge to BCK HIGH	10	-	-	ns
$t_h$	hold time	BCK HIGH to WS edge	[3] 10	-	-	ns
		BCK HIGH to DATA edge	10	-	-	ns
$t_j$	external clock jitter	PLL locked on BCK	[4] -	1	2	ns
		PLL locked on FS	[5] -	-	20	ns

- [1]  $L_{BST}$  = boost converter inductance;  $R_L$  = load resistance;  $L_L$  = load inductance.
- [2] The TDM bit clock input (BCK) is used as a clock input for the amplifier and the DC-to-DC converter. Note that both the BCK and WS signals need to be present for the clock to operate correctly.
- [3] This parameter is not tested during production; the value is guaranteed by design and checked during product validation.
- [4] When the PLL is locked on BCK, amplifier output noise can deteriorate when clock jitter >1 ns; performance is guaranteed up to jitter = 2 ns.
- [5] The system is less sensitive to jitter when the PLL is locked on FS.

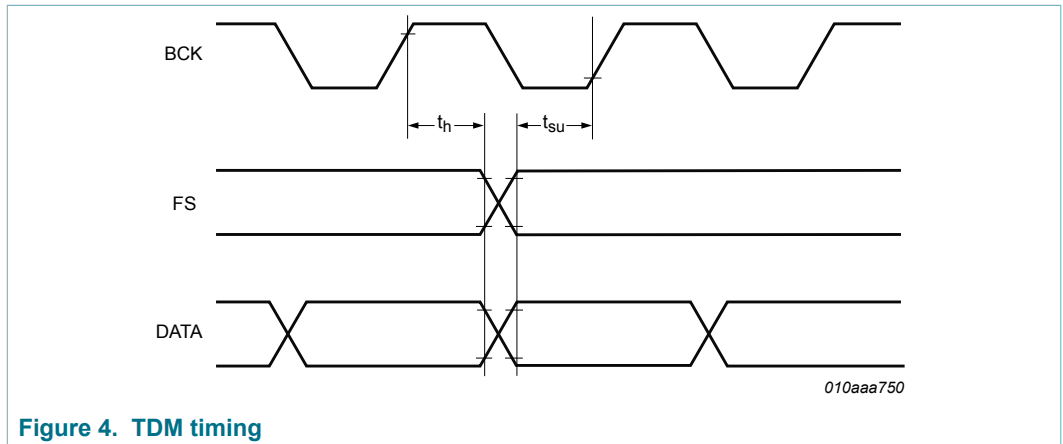

**Figure 4. TDM timing**

### 11.4 I<sup>2</sup>C timing characteristics

**Table 9. I<sup>2</sup>C-bus interface characteristics**

All parameters are guaranteed for  $V_{BAT} = 4.0\text{ V}$ ;  $V_{DD} = 1.8\text{ V}$ ;  $V_{DDP} = V_{BST} = 8.5\text{ V}$ , adaptive boost mode;  $L_{BST} = 1\text{ }\mu\text{H}^{[1]}$ ;  $R_L = 8\text{ }\Omega^{[1]}$ ;  $L_L = 44\text{ }\mu\text{H}^{[1]}$ ;  $f_i = 1\text{ kHz}$ ;  $f_s = 48\text{ kHz}$ ;  $T_{amb} = 25\text{ }^\circ\text{C}$ ; default settings, unless otherwise specified.

Symbol	Parameter	Conditions	Min	Typ	Max	Unit
$f_{SCL}$	SCL clock frequency		-	-	400	kHz
$t_{LOW}$	LOW period of the SCL clock		1.3	-	-	$\mu\text{s}$
$t_{HIGH}$	HIGH period of the SCL clock		0.6	-	-	$\mu\text{s}$
$t_r$	rise time	SDA and SCL signals	[2] $20 + 0.1 C_b$	-	-	ns
$t_f$	fall time	SDA and SCL signals	[2] $20 + 0.1 C_b$	-	-	ns
$t_{HD;STA}$	hold time (repeated) START condition		[3] 0.6	-	-	$\mu\text{s}$
$t_{SU;STA}$	set-up time for a repeated START condition		0.6	-	-	$\mu\text{s}$
$t_{SU;STO}$	set-up time for STOP condition		0.6	-	-	$\mu\text{s}$
$t_{BUF}$	bus free time between a STOP and START condition		1.3	-	-	$\mu\text{s}$
$t_{SU;DAT}$	data set-up time		100	-	-	ns
$t_{HD;DAT}$	data hold time		0	-	-	$\mu\text{s}$
$t_{SP}$	pulse width of spikes that must be suppressed by the input filter		[4] 0	-	50	ns
$C_b$	capacitive load for each bus line		-	-	400	pF

- [1]  $L_{BST}$  = boost converter inductance;  $R_L$  = load resistance;  $L_L$  = load inductance (speaker).
- [2]  $C_b$  is the total capacitance of one bus line in pF. The maximum capacitive load for each bus line is 400 pF.
- [3] After this period, the first clock pulse is generated.
- [4] To be suppressed by the input filter.

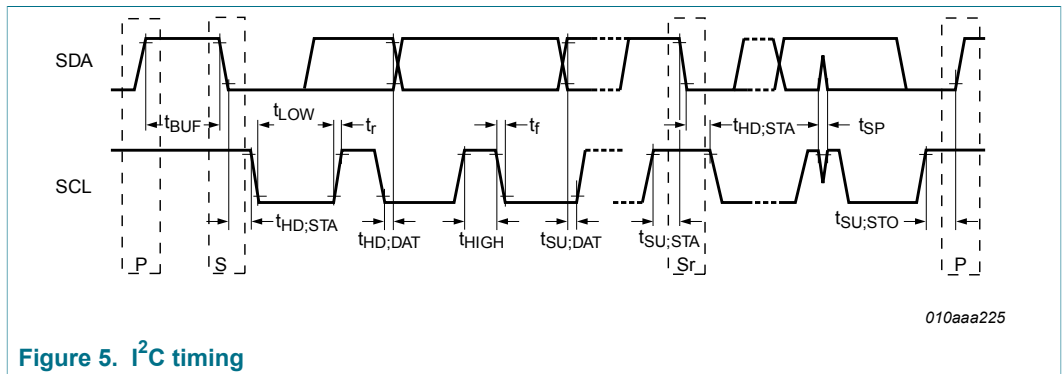

Figure 5. I<sup>2</sup>C timing

## 12 Application information

### 12.1 Application diagrams

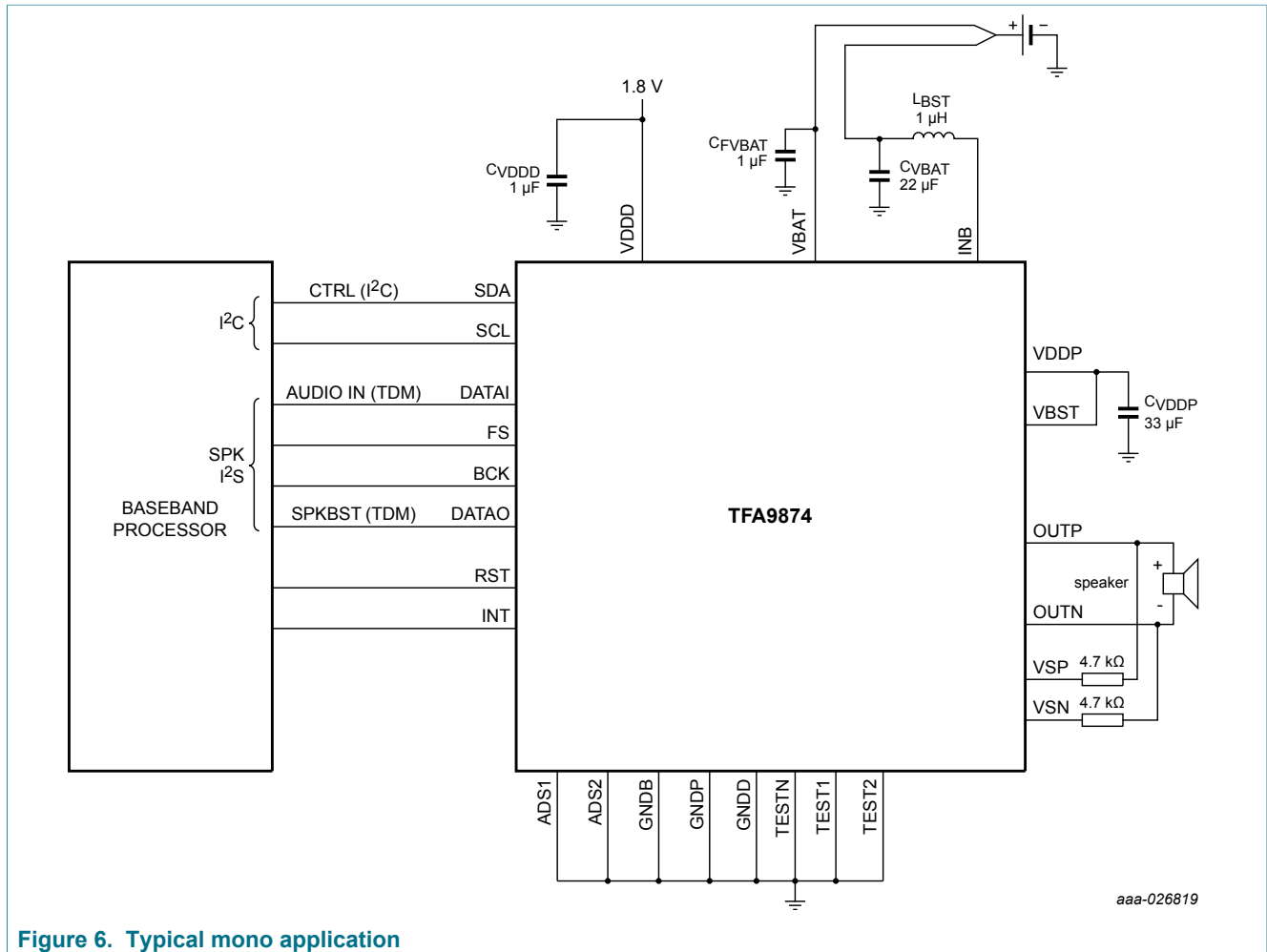
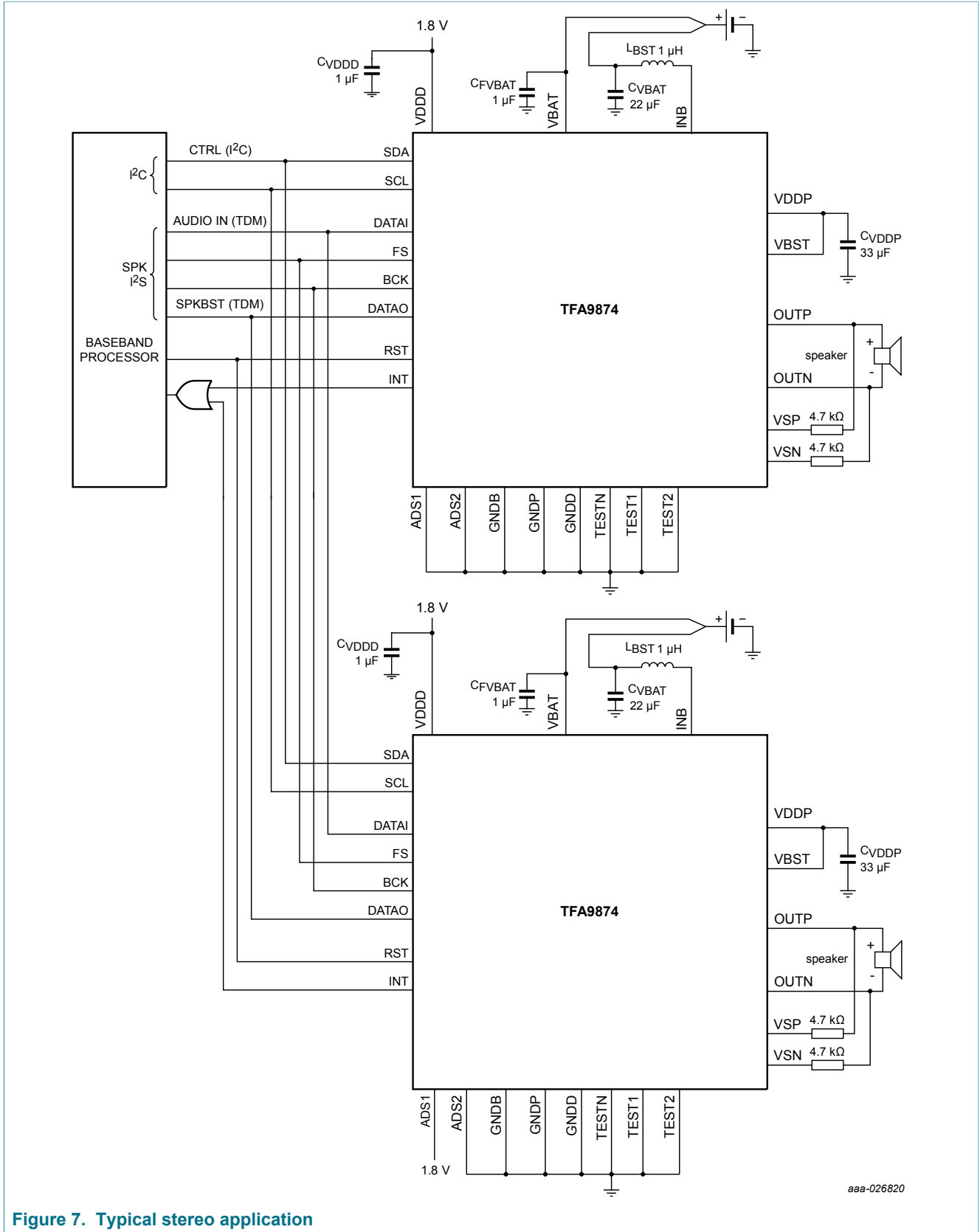

Figure 6. Typical mono application



aaa-026820

Figure 7. Typical stereo application



13 Package outline

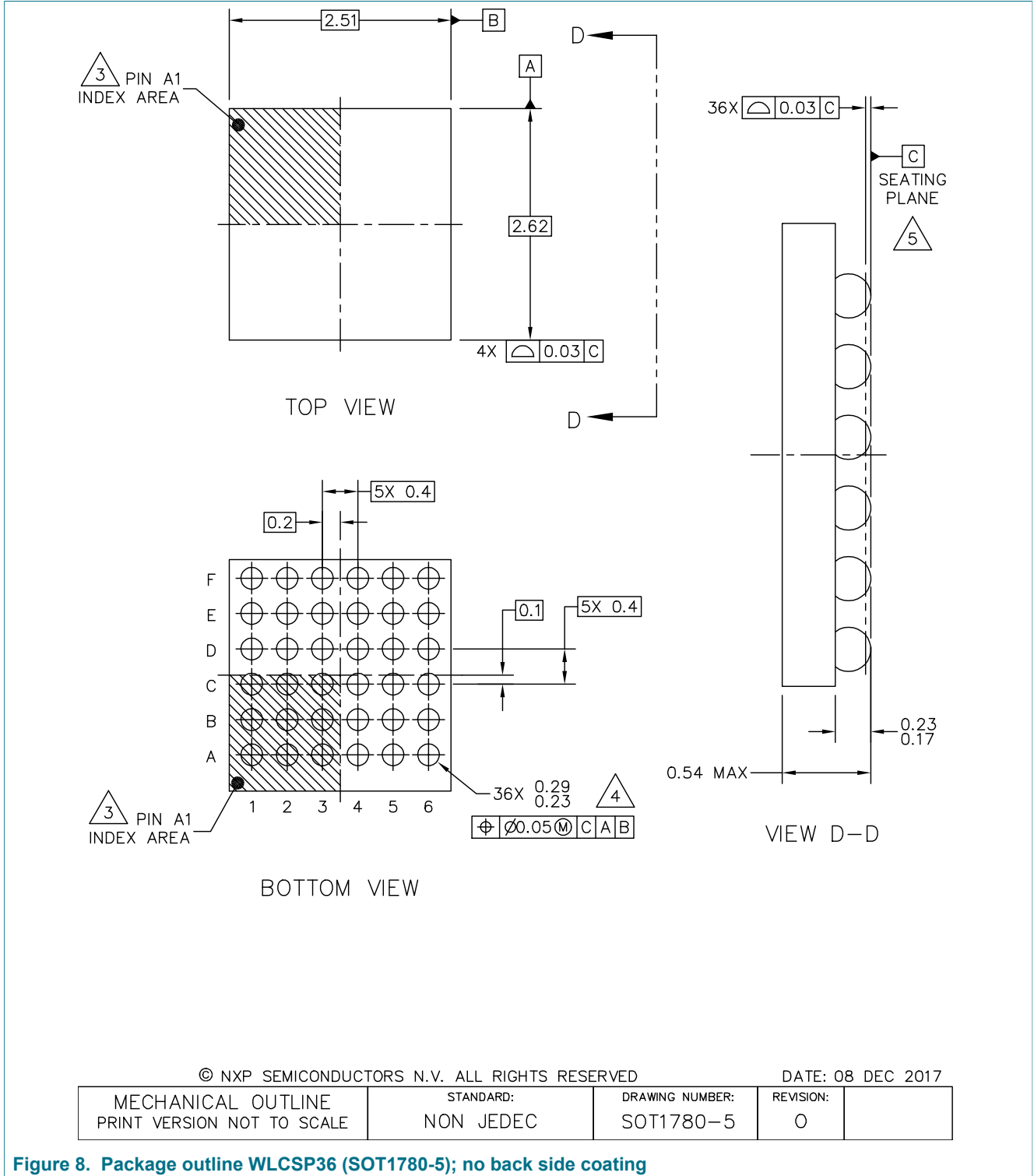

Figure 8. Package outline WLCSP36 (SOT1780-5); no back side coating

## 14 Soldering of WLCSP packages

### 14.1 Introduction to soldering WLCSP packages

This text provides a very brief insight into a complex technology. A more in-depth account of soldering WLCSP (Wafer Level Chip-Size Packages) can be found in application note AN10439 "Wafer Level Chip Scale Package" and in application note AN10365 "Surface mount reflow soldering description".

Wave soldering is not suitable for this package.

All NXP WLCSP packages are lead-free.

### 14.2 Board mounting

Board mounting of a WLCSP requires several steps:

1. Solder paste printing on the PCB
2. Component placement with a pick and place machine
3. The reflow soldering itself

### 14.3 Reflow soldering

Key characteristics in reflow soldering are:

- Lead-free versus SnPb soldering; note that a lead-free reflow process usually leads to higher minimum peak temperatures (see [Figure 9](#)) than a SnPb process, thus reducing the process window
- Solder paste printing issues, such as smearing, release, and adjusting the process window for a mix of large and small components on one board
- Reflow temperature profile; this profile includes preheat, reflow (in which the board is heated to the peak temperature), and cooling down. It is imperative that the peak temperature is high enough for the solder to make reliable solder joints (a solder paste characteristic) while being low enough that the packages and/or boards are not damaged. The peak temperature of the package depends on package thickness and volume and is classified in accordance with [Table 10](#).

**Table 10. Lead-free process (from J-STD-020D)**

Package thickness (mm)	Package reflow temperature (°C)		
	Volume (mm <sup>3</sup> )		
	< 350	350 to 2 000	> 2 000
< 1.6	260	260	260
1.6 to 2.5	260	250	245
> 2.5	250	245	245

Moisture sensitivity precautions, as indicated on the packing, must be respected at all times.

Studies have shown that small packages reach higher temperatures during reflow soldering, see [Figure 9](#).

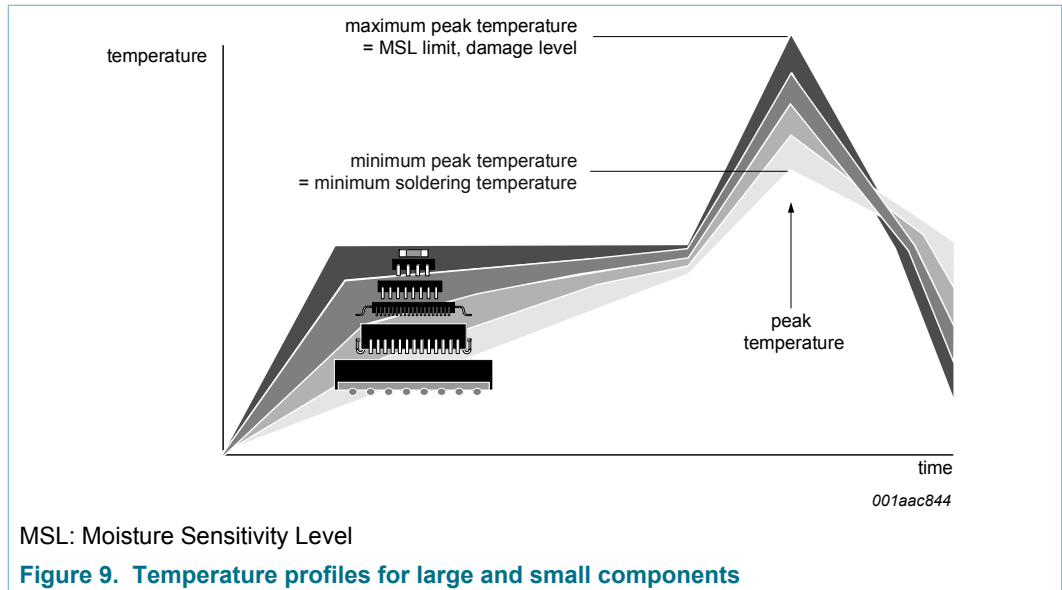

For further information on temperature profiles, refer to application note AN10365 "Surface mount reflow soldering description".

**14.3.1 Stand off**

The stand off between the substrate and the chip is determined by:

- The amount of printed solder on the substrate
- The size of the solder land on the substrate
- The bump height on the chip

The higher the stand off, the better the stresses are released due to TEC (Thermal Expansion Coefficient) differences between substrate and chip.

**14.3.2 Quality of solder joint**

A flip-chip joint is considered to be a good joint when the entire solder land has been wetted by the solder from the bump. The surface of the joint should be smooth and the shape symmetrical. The soldered joints on a chip should be uniform. Voids in the bumps after reflow can occur during the reflow process in bumps with high ratio of bump diameter to bump height, i.e. low bumps with large diameter. No failures have been found to be related to these voids. Solder joint inspection after reflow can be done with X-ray to monitor defects such as bridging, open circuits and voids.

**14.3.3 Rework**

In general, rework is not recommended. By rework we mean the process of removing the chip from the substrate and replacing it with a new chip. If a chip is removed from the substrate, most solder balls of the chip will be damaged. In that case it is recommended not to re-use the chip again.

Device removal can be done when the substrate is heated until it is certain that all solder joints are molten. The chip can then be carefully removed from the substrate without damaging the tracks and solder lands on the substrate. Removing the device must be done using plastic tweezers, because metal tweezers can damage the silicon. The

surface of the substrate should be carefully cleaned and all solder and flux residues and/or underfill removed. When a new chip is placed on the substrate, use the flux process instead of solder on the solder lands. Apply flux on the bumps at the chip side as well as on the solder pads on the substrate. Place and align the new chip while viewing with a microscope. To reflow the solder, use the solder profile shown in application note *AN10365 "Surface mount reflow soldering description"*.

#### 14.3.4 Cleaning

Cleaning can be done after reflow soldering.

## 15 Revision history

Table 11. Revision history

Document ID	Release date	Data sheet status	Change notice	Supersedes
TFA9871_SDS v.1	20180814	Product data sheet	-	-

## 16 Legal information

### 16.1 Data sheet status

Document status <sup>[1][2]</sup>	Product status <sup>[3]</sup>	Definition
Objective [short] data sheet	Development	This document contains data from the objective specification for product development.
Preliminary [short] data sheet	Qualification	This document contains data from the preliminary specification.
Product [short] data sheet	Production	This document contains the product specification.

[1] Please consult the most recently issued document before initiating or completing a design.

[2] The term 'short data sheet' is explained in section "Definitions".

[3] The product status of device(s) described in this document may have changed since this document was published and may differ in case of multiple devices. The latest product status information is available on the Internet at URL <http://www.nxp.com>.

### 16.2 Definitions

**Draft** — The document is a draft version only. The content is still under internal review and subject to formal approval, which may result in modifications or additions. NXP Semiconductors does not give any representations or warranties as to the accuracy or completeness of information included herein and shall have no liability for the consequences of use of such information.

**Short data sheet** — A short data sheet is an extract from a full data sheet with the same product type number(s) and title. A short data sheet is intended for quick reference only and should not be relied upon to contain detailed and full information. For detailed and full information see the relevant full data sheet, which is available on request via the local NXP Semiconductors sales office. In case of any inconsistency or conflict with the short data sheet, the full data sheet shall prevail.

**Product specification** — The information and data provided in a Product data sheet shall define the specification of the product as agreed between NXP Semiconductors and its customer, unless NXP Semiconductors and customer have explicitly agreed otherwise in writing. In no event however, shall an agreement be valid in which the NXP Semiconductors product is deemed to offer functions and qualities beyond those described in the Product data sheet.

### 16.3 Disclaimers

**Limited warranty and liability** — Information in this document is believed to be accurate and reliable. However, NXP Semiconductors does not give any representations or warranties, expressed or implied, as to the accuracy or completeness of such information and shall have no liability for the consequences of use of such information. NXP Semiconductors takes no responsibility for the content in this document if provided by an information source outside of NXP Semiconductors. In no event shall NXP Semiconductors be liable for any indirect, incidental, punitive, special or consequential damages (including - without limitation - lost profits, lost savings, business interruption, costs related to the removal or replacement of any products or rework charges) whether or not such damages are based on tort (including negligence), warranty, breach of contract or any other legal theory. Notwithstanding any damages that customer might incur for any reason whatsoever, NXP Semiconductors' aggregate and cumulative liability towards customer for the products described herein shall be limited in accordance with the Terms and conditions of commercial sale of NXP Semiconductors.

**Right to make changes** — NXP Semiconductors reserves the right to make changes to information published in this document, including without limitation specifications and product descriptions, at any time and without

notice. This document supersedes and replaces all information supplied prior to the publication hereof.

**Suitability for use** — NXP Semiconductors products are not designed, authorized or warranted to be suitable for use in life support, life-critical or safety-critical systems or equipment, nor in applications where failure or malfunction of an NXP Semiconductors product can reasonably be expected to result in personal injury, death or severe property or environmental damage. NXP Semiconductors and its suppliers accept no liability for inclusion and/or use of NXP Semiconductors products in such equipment or applications and therefore such inclusion and/or use is at the customer's own risk.

**Applications** — Applications that are described herein for any of these products are for illustrative purposes only. NXP Semiconductors makes no representation or warranty that such applications will be suitable for the specified use without further testing or modification. Customers are responsible for the design and operation of their applications and products using NXP Semiconductors products, and NXP Semiconductors accepts no liability for any assistance with applications or customer product design. It is customer's sole responsibility to determine whether the NXP Semiconductors product is suitable and fit for the customer's applications and products planned, as well as for the planned application and use of customer's third party customer(s). Customers should provide appropriate design and operating safeguards to minimize the risks associated with their applications and products. NXP Semiconductors does not accept any liability related to any default, damage, costs or problem which is based on any weakness or default in the customer's applications or products, or the application or use by customer's third party customer(s). Customer is responsible for doing all necessary testing for the customer's applications and products using NXP Semiconductors products in order to avoid a default of the applications and the products or of the application or use by customer's third party customer(s). NXP does not accept any liability in this respect.

**Limiting values** — Stress above one or more limiting values (as defined in the Absolute Maximum Ratings System of IEC 60134) will cause permanent damage to the device. Limiting values are stress ratings only and (proper) operation of the device at these or any other conditions above those given in the Recommended operating conditions section (if present) or the Characteristics sections of this document is not warranted. Constant or repeated exposure to limiting values will permanently and irreversibly affect the quality and reliability of the device.

**Terms and conditions of commercial sale** — NXP Semiconductors products are sold subject to the general terms and conditions of commercial sale, as published at <http://www.nxp.com/profile/terms>, unless otherwise agreed in a valid written individual agreement. In case an individual agreement is concluded only the terms and conditions of the respective agreement shall apply. NXP Semiconductors hereby expressly objects to applying the customer's general terms and conditions with regard to the purchase of NXP Semiconductors products by customer.

**No offer to sell or license** — Nothing in this document may be interpreted or construed as an offer to sell products that is open for acceptance or the grant, conveyance or implication of any license under any copyrights, patents or other industrial or intellectual property rights.

**Quick reference data** — The Quick reference data is an extract of the product data given in the Limiting values and Characteristics sections of this document, and as such is not complete, exhaustive or legally binding.

**Export control** — This document as well as the item(s) described herein may be subject to export control regulations. Export might require a prior authorization from competent authorities.

**Non-automotive qualified products** — Unless this data sheet expressly states that this specific NXP Semiconductors product is automotive qualified, the product is not suitable for automotive use. It is neither qualified nor tested in accordance with automotive testing or application requirements. NXP Semiconductors accepts no liability for inclusion and/or use of non-automotive qualified products in automotive equipment or applications. In the event that customer uses the product for design-in and use in automotive applications to automotive specifications and standards, customer (a) shall use the product without NXP Semiconductors' warranty of the product for such automotive applications, use and specifications, and (b) whenever customer uses the product for automotive applications beyond NXP

Semiconductors' specifications such use shall be solely at customer's own risk, and (c) customer fully indemnifies NXP Semiconductors for any liability, damages or failed product claims resulting from customer design and use of the product for automotive applications beyond NXP Semiconductors' standard warranty and NXP Semiconductors' product specifications.

**Translations** — A non-English (translated) version of a document is for reference only. The English version shall prevail in case of any discrepancy between the translated and English versions.

**Security** — While NXP Semiconductors has implemented advanced security features, all products may be subject to unidentified vulnerabilities. Customers are responsible for the design and operation of their applications and products to reduce the effect of these vulnerabilities on customer's applications and products, and NXP Semiconductors accepts no liability for any vulnerability that is discovered. Customers should implement appropriate design and operating safeguards to minimize the risks associated with their applications and products.

## 16.4 Trademarks

Notice: All referenced brands, product names, service names and trademarks are the property of their respective owners.

## Contents

<b>1</b>	<b>General description</b> .....	<b>1</b>
<b>2</b>	<b>Features and benefits</b> .....	<b>1</b>
<b>3</b>	<b>Applications</b> .....	<b>2</b>
<b>4</b>	<b>Quick reference data</b> .....	<b>2</b>
<b>5</b>	<b>Ordering information</b> .....	<b>3</b>
<b>6</b>	<b>Block diagram</b> .....	<b>4</b>
<b>7</b>	<b>Pinning information</b> .....	<b>5</b>
7.1	Pinning .....	5
<b>8</b>	<b>Functional description</b> .....	<b>7</b>
<b>9</b>	<b>Limiting values</b> .....	<b>8</b>
<b>10</b>	<b>Thermal characteristics</b> .....	<b>8</b>
<b>11</b>	<b>Characteristics</b> .....	<b>9</b>
11.1	DC Characteristics .....	9
11.2	AC characteristics .....	10
11.3	TDM timing characteristics .....	13
11.4	I2C timing characteristics .....	14
<b>12</b>	<b>Application information</b> .....	<b>15</b>
12.1	Application diagrams .....	15
<b>13</b>	<b>Package outline</b> .....	<b>17</b>
<b>14</b>	<b>Soldering of WLCSP packages</b> .....	<b>18</b>
14.1	Introduction to soldering WLCSP packages .....	18
14.2	Board mounting .....	18
14.3	Reflow soldering .....	18
14.3.1	Stand off .....	19
14.3.2	Quality of solder joint .....	19
14.3.3	Rework .....	19
14.3.4	Cleaning .....	20
<b>15</b>	<b>Revision history</b> .....	<b>21</b>
<b>16</b>	<b>Legal information</b> .....	<b>22</b>

---

Please be aware that important notices concerning this document and the product(s) described herein, have been included in section 'Legal information'.

---

© NXP B.V. 2018.

All rights reserved.

For more information, please visit: <http://www.nxp.com>

For sales office addresses, please send an email to: [salesaddresses@nxp.com](mailto:salesaddresses@nxp.com)

Date of release: 14 August 2018

Document identifier: TFA9871