

ASM1233D, ASM1233D-L, ASM1233M

Low Power, 5 V/3.3 V, μP Reset, Active LOW, Open-Drain Output

Description

The ASM1233D-L/1233D/1233M are voltage supervisors with low-power, 5/3.3 V μP Reset, with an active LOW, open-drain output. Maximum supply current over temperature is 15 μA for 3.3 V devices and 20 μA for 5 V devices.

The ASM1233D-L/1233D/1233M generates an active LOW reset signal whenever the monitored supply is out of tolerance. A precision reference and comparator circuit monitors power supply (V_{CC}) level. The tolerances are 5%, 10% and 15%. When an out-of-tolerance condition is detected, an internal power-fail signal is generated which forces an active LOW reset signal. After V_{CC} returns to an in-tolerance condition, the reset signal remains active for 350 ms to allow the power supply and system microprocessor to stabilize.

The ASM1233D-L/1233D/1233M is designed with an open drain output stage and operates over the extended industrial temperature range. These devices are available in compact SOT-223, SO-8 and TO-92 packages.

Other low power products in this family include ASM1810/11/12/15/16/17.

Features

- Low Supply Current
- 15 μA Maximum (≤ 3.6 V), 20 μA Maximum (5.5 V)
- Automatically Restarts a Microprocessor after Power Failure
- 350 ms Reset Delay after V_{CC} Returns to an In-tolerance Condition
- Active LOW Power-up Reset, 5 kΩ Internal Pull-up
- Precision Temperature-compensated Voltage Reference and Comparator
- Eliminates External Components
- Low-cost SOT-223/SO-8/TO-92 Packages
- Operating Temperature: -40°C to +85°C

Applications

- Set-top Boxes
- Cellular Phones
- PDAs
- Energy Management Systems
- Embedded Control Systems
- Printers
- Single Board Computers



ON Semiconductor®

<http://onsemi.com>

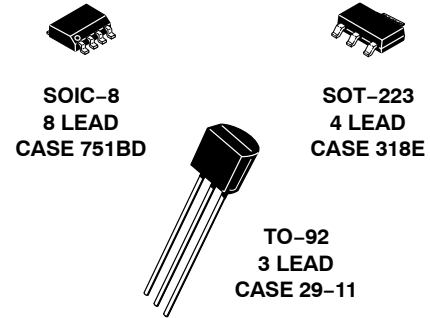

PIN CONFIGURATIONS

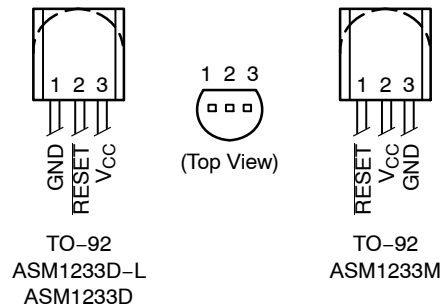
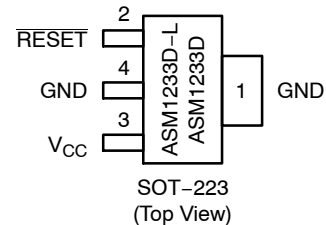
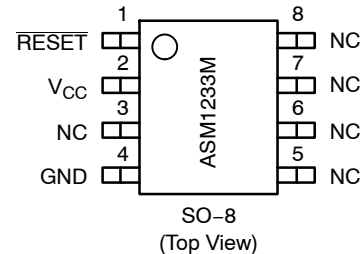

ORDERING INFORMATION

See detailed ordering and shipping information in the package dimensions section on page 9 of this data sheet.

ASM1233D, ASM1233D-L, ASM1233M

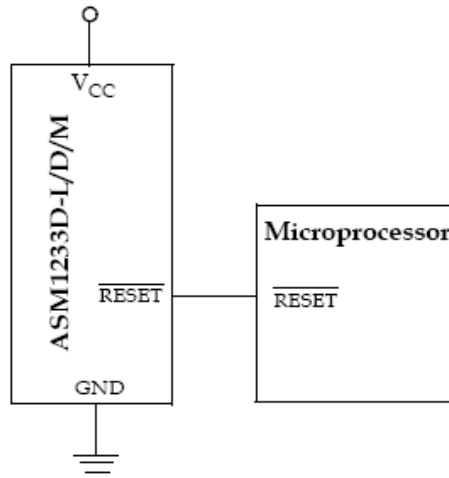

Figure 1. Typical Operating Circuit

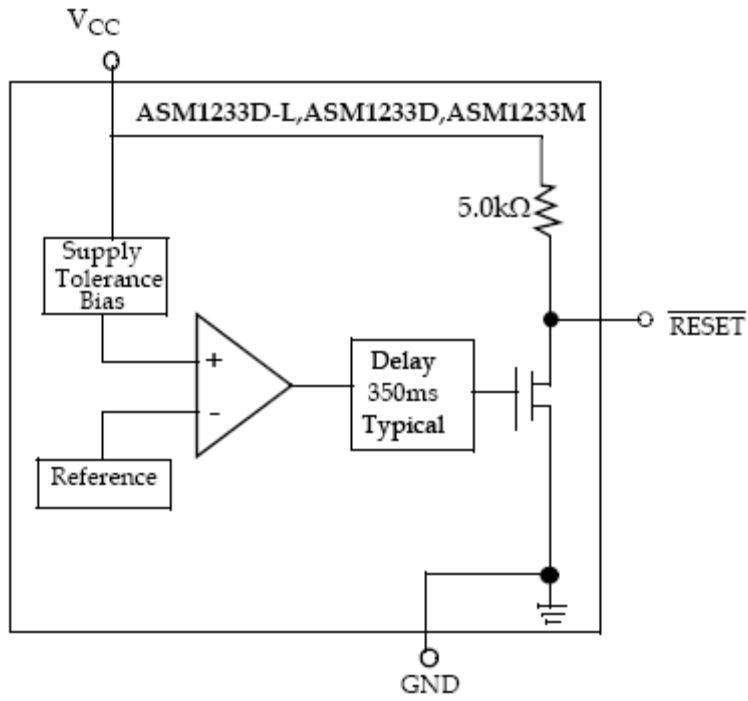

Figure 2. Block Diagram

ASM1233D, ASM1233D-L, ASM1233M

Table 1. PIN DESCRIPTION

Pin #				Pin Name	Description
TO-92 ASM1233D-L ASM1233D	TO-92 ASM1233M	SO-8	SOT-223		
1	3	4	1,4	GND	Ground.
2	1	1	2	RESET	Active LOW reset output.
3	2	2	3	V _{CC}	Power supply input.
		3, 5, 6, 7 & 8		NC	No connection.

Table 2. ABSOLUTE MAXIMUM RATINGS

Parameter	Min	Max	Unit
Voltage on V _{CC} (Note 1)	-0.5	7	V
Voltage on RESET (Note 1)	-0.5	V _{CC} + 0.5	V
Operating Temperature Range	-40	+85	°C
Soldering Temperature (for 10 sec)		+260	°C
Storage Temperature	-55	+125	°C
ESD rating	HBM	2	KV
	MM	200	V

Stresses exceeding Maximum Ratings may damage the device. Maximum Ratings are stress ratings only. Functional operation above the Recommended Operating Conditions is not implied. Extended exposure to stresses above the Recommended Operating Conditions may affect device reliability.

1. Voltages are measured with respect to ground.

ASM1233D, ASM1233D-L, ASM1233M

Table 3. DC ELECTRICAL CHARACTERISTICS (Unless otherwise noted, $V_{CC} = 5\text{ V} \pm 10\%$ and specifications are over the operating temperature range of -40°C to $+85^{\circ}\text{C}$. All voltages are referenced to ground.) (Note 2)

Parameter	Symbol	Conditions	Min	Typ	Max	Unit
Supply Voltage	V_{CC}		1.2		5.5	V
Output Voltage	V_{OL}	RESET asserted			0.4	V
	V_{OH}	$I_{OUT} < 500\ \mu\text{A}$	$V_{CC}-0.5\ \text{V}$	$V_{CC}-0.1\ \text{V}$		
Output Current	I_{OL}	Output = 0.4 V	8			mA
Operating Current	I_{CC}	$V_{CC} < 5.5\ \text{V}$, RESET output open		8	20	μA
		$V_{CC} \leq 3.6\ \text{V}$, RESET output open		6	15	
V _{CC} Trip Point	V_{CCTP}	ASM1233D-LZ-5	2.98	3.06	3.15	V
		ASM1233D-LZ-10	2.8	2.88	2.97	
		ASM1233D-LZ-15	2.64	2.72	2.8	
		ASM1233DZ-5	4.5	4.625	4.74	
		ASM1233DZ-10	4.25	4.375	4.49	
		ASM1233DZ-15	4.0	4.125	4.24	
		ASM1233M-5	4.25	4.375	4.49	
		ASM1233M-55	4.5	4.625	4.75	
		ASM1233M-3	2.64	2.72	2.8	
Voltage High Trip Level	V_{HTL}	ASM1233D, ASM1233MS-5, ASM1233MS-55			4.75	V
		ASM1233MS-3			3.14	
		ASM1233D-L			3.06	
Voltage Low Trip Level	V_{LTL}	ASM1233D, ASM1233MS-5, ASM1233MS-55			4.00	V
		ASM1233MS-3			2.48	
		ASM1233D-L			2.3	
Internal Pull-up Resistor	R_P		3.5	5.0	7.5	k Ω
Output Capacitance	C_{OUT}				10	pF
V _{CC} Detect to RESET Low	t_{RPD}			2	10	μs
V _{CC} Detect to RESET High	t_{RPU}	ASM1233D-L, ASM1233M	200	350	500	ms
		ASM1233D	250	350	450	
V _{CC} Slew Rate ($V_{HTL} - V_{LTL}$)	t_F		300			μs
V _{CC} Slew Rate ($V_{LTL} - V_{HTL}$)	t_R		0			ns

2. A 1 k Ω resistor may be required in some applications for proper operation of the microprocessor reset control circuit.

ASM1233D, ASM1233D-L, ASM1233M

Table 4. FAMILY SELECTION GUIDE

Part #	RESET Voltage (V)	RESET Time (ms)	Output Stage	RESET Polarity
ASM1810	4.620, 4.370, 4.120	150	Push-Pull	LOW
ASM1811	4.620, 4.350, 4.130	150	Open-Drain	LOW
ASM1812	4.620, 4.350, 4.130	150	Push-Pull	HIGH
ASM1815	3.060, 2.880, 2.550	150	Push-Pull	LOW
ASM1816	3.060, 2.880, 2.550	150	Open-Drain	LOW
ASM1817	3.060, 2.880, 2.550	150	Push-Pull	HIGH
ASM1233D	4.625, 4.375, 4.125	350	Open-Drain	LOW
ASM1233M	4.625, 4.375, 2.720	350	Open-Drain	LOW
ASM1233D-L	3.060, 2.880, 2.720	350	Open-Drain	LOW

Application Information

Operation – Power Monitor

The ASM1233D-L/1233D/1233M detects out-of-tolerance Power supply conditions. It resets a processor during powerup, Power-down and generates a reset to the system Processor when the monitored power supply voltage is below the reset threshold. When an out-of-tolerance V_{CC}

voltage is detected, the $\overline{\text{RESET}}$ signal is asserted. On power-up, $\overline{\text{RESET}}$ is kept active (LOW) for approximately 350 ms after the power supply voltage has reached the selected tolerance. This allows the power supply and microprocessor to stabilize before $\overline{\text{RESET}}$ is released.

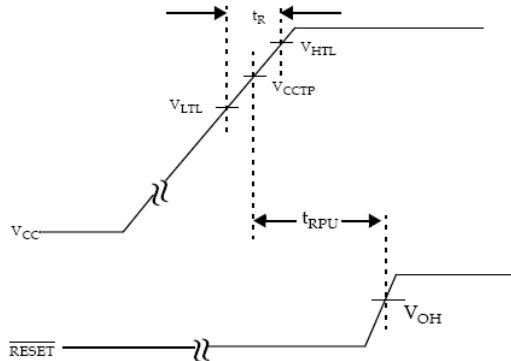

Figure 3. Timing Diagram: Power-Up

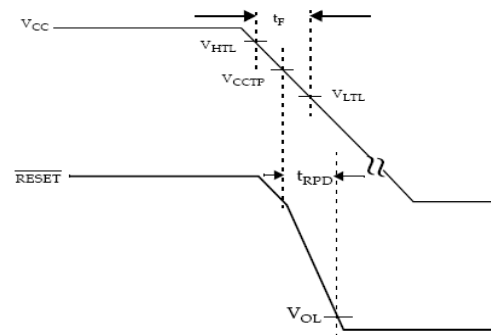
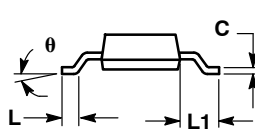
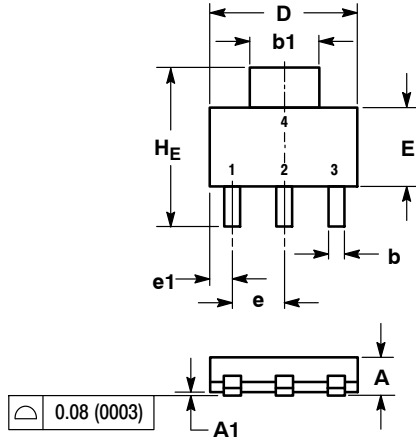

Figure 4. Timing Diagram: Power-Down

ASM1233D, ASM1233D-L, ASM1233M

PACKAGE DIMENSIONS

SOT-223 (TO-261)
CASE 318E-04
ISSUE N



NOTES:
1. DIMENSIONING AND TOLERANCING PER ASME Y14.5M, 1994.
2. CONTROLLING DIMENSION: INCH.

DIM	MILLIMETERS			INCHES		
	MIN	NOM	MAX	MIN	NOM	MAX
A	1.50	1.63	1.75	0.060	0.064	0.068
A1	0.02	0.06	0.10	0.001	0.002	0.004
b	0.60	0.75	0.89	0.024	0.030	0.035
b1	2.90	3.06	3.20	0.115	0.121	0.126
c	0.24	0.29	0.35	0.009	0.012	0.014
D	6.30	6.50	6.70	0.249	0.256	0.263
E	3.30	3.50	3.70	0.130	0.138	0.145
e	2.20	2.30	2.40	0.087	0.091	0.094
e1	0.85	0.94	1.05	0.033	0.037	0.041
L	0.20	---	---	0.008	---	---
L1	1.50	1.75	2.00	0.060	0.069	0.078
HE	6.70	7.00	7.30	0.264	0.276	0.287
θ	0°	-	10°	0°	-	10°

SOLDERING FOOTPRINT

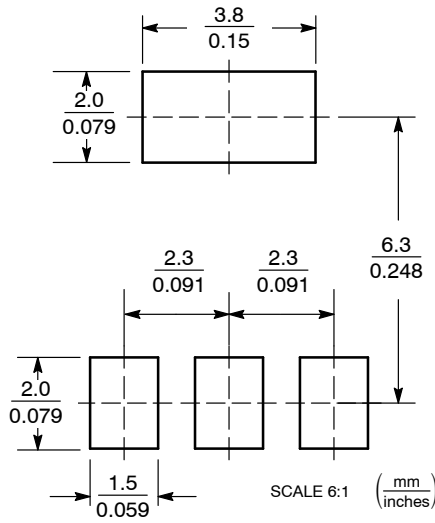

ASM1233D, ASM1233D-L, ASM1233M

PACKAGE DIMENSIONS

TO-92 (TO-226)
CASE 29-11
ISSUE AM

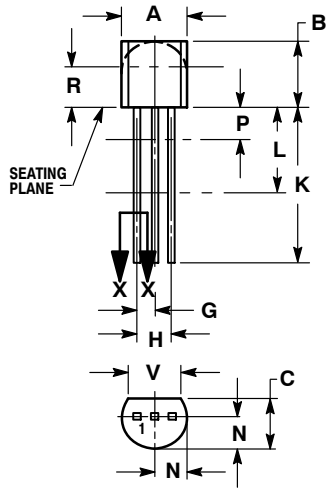

STRAIGHT LEAD
BULK PACK

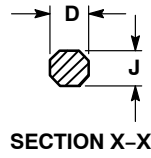

NOTES:

1. DIMENSIONING AND TOLERANCING PER ANSI Y14.5M, 1982.
2. CONTROLLING DIMENSION: INCH.
3. CONTOUR OF PACKAGE BEYOND DIMENSION R IS UNCONTROLLED.
4. LEAD DIMENSION IS UNCONTROLLED IN P AND BEYOND DIMENSION K MINIMUM.

DIM	INCHES		MILLIMETERS	
	MIN	MAX	MIN	MAX
A	0.175	0.205	4.45	5.20
B	0.170	0.210	4.32	5.33
C	0.125	0.165	3.18	4.19
D	0.016	0.021	0.407	0.533
G	0.045	0.055	1.15	1.39
H	0.095	0.105	2.42	2.66
J	0.015	0.020	0.39	0.50
K	0.500	---	12.70	---
L	0.250	---	6.35	---
N	0.080	0.105	2.04	2.66
P	---	0.100	---	2.54
R	0.115	---	2.93	---
V	0.135	---	3.43	---

ASM1233D, ASM1233D-L, ASM1233M

PACKAGE DIMENSIONS

SOIC 8, 150 mils
CASE 751BD-01
ISSUE O

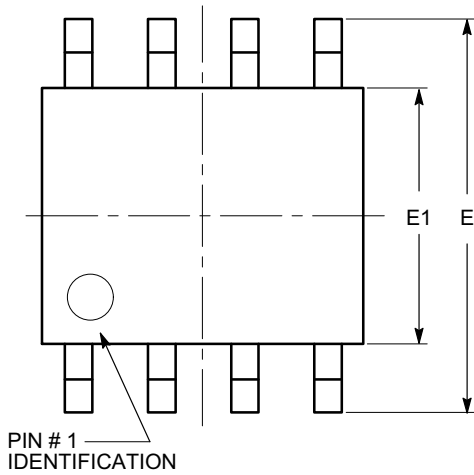

TOP VIEW

SYMBOL	MIN	NOM	MAX
A	1.35		1.75
A1	0.10		0.25
b	0.33		0.51
c	0.19		0.25
D	4.80		5.00
E	5.80		6.20
E1	3.80		4.00
e	1.27 BSC		
h	0.25		0.50
L	0.40		1.27
θ	0°		8°

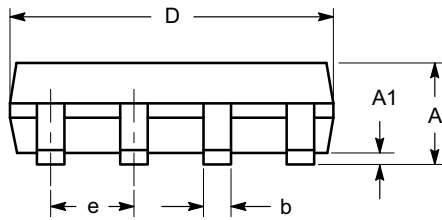

SIDE VIEW

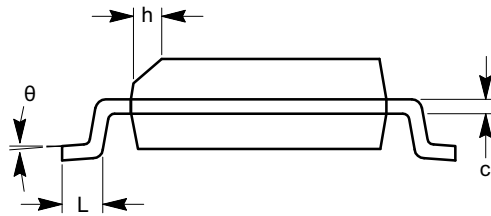

END VIEW

Notes:

- (1) All dimensions are in millimeters. Angles in degrees.
- (2) Complies with JEDEC MS-012.

ASM1233D, ASM1233D-L, ASM1233M

Table 5. ORDERING INFORMATION

Part Number	RESET Output Voltage	RESET Tolerance	RESET Time	Open Drain Output	RESET Polarity	Package	Package Marking
TIN - LEAD DEVICES							
ASM1233D-L-5 (ASM1233A-5)	3.06	5%	350 ms	◆	LOW	3L TO-92	ASM1233D-L-5
ASM1233D-L-10 (ASM1233A-10)	2.88	10%	350 ms	◆	LOW	3L TO-92	ASM1233D-L-10
ASM1233D-L-15 (ASM1233A-15)	2.72	15%	350 ms	◆	LOW	3L TO-92	ASM1233D-L-15
ASM1233D-LZ-5 (ASM1233AZ-5)	3.06	5%	350 ms	◆	LOW	4L SOT-223	RVLL
ASM1233D-LZ-10 (ASM1233AZ-10)	2.88	10%	350 ms	◆	LOW	4L SOT-223	RWLL
ASM1233D-LZ-15 (ASM1233AZ-15)	2.72	15%	350 ms	◆	LOW	4L SOT-223	RXLL
ASM1233D-5	4.625	5%	350 ms	◆	LOW	3L TO-92	ASM1233D-5
ASM1233D-10	4.375	10%	350 ms	◆	LOW	3L TO-92	ASM1233D-10
ASM1233D-15	4.125	15%	350 ms	◆	LOW	3L TO-92	ASM1233D-15
ASM1233DZ-5	4.625	5%	350 ms	◆	LOW	4L SOT-223	RSLL
ASM1233DZ-10	4.375	10%	350 ms	◆	LOW	4L SOT-223	RTLL
ASM1233DZ-15	4.125	15%	350 ms	◆	LOW	4L SOT-223	RULL
ASM1233M-55	4.625	5%	350 ms	◆	LOW	3L TO-92	ASM1233M-55
ASM1233M-5	4.375	10%	350 ms	◆	LOW	3L TO-92	ASM1233M-5
ASM1233M-3	2.72	15%	350 ms	◆	LOW	3L TO-92	ASM1233M-3
ASM1233MS-55	4.625	5%	350 ms	◆	LOW	8L SOIC	ASM1233MS-55
ASM1233MS-5	4.38	10%	350 ms	◆	LOW	8L SOIC	ASM1233MS-5
ASM1233MS-3	2.72	15%	350 ms	◆	LOW	8L SOIC	ASM1233MS-3
LEAD FREE DEVICES							
ASM1233D-L-5F	3.06	5%	350 ms	◆	LOW	3L TO-92	ASM1233D-L-5F
ASM1233D-L-10F	2.88	10%	350 ms	◆	LOW	3L TO-92	ASM1233D-L-10F
ASM1233D-L-15F	2.72	15%	350 ms	◆	LOW	3L TO-92	ASM1233D-L-15F
ASM1233D-LZ-5F	3.06	5%	350 ms	◆	LOW	4L SOT-223	KVLL
ASM1233D-LZ-10F	2.88	10%	350 ms	◆	LOW	4L SOT-223	KWLL
ASM1233D-LZ-15F	2.72	15%	350 ms	◆	LOW	4L SOT-223	KXLL
ASM1233D-5F	4.625	5%	350 ms	◆	LOW	3L TO-92	ASM1233D-5F
ASM1233D-10F	4.375	10%	350 ms	◆	LOW	3L TO-92	ASM1233D-10F
ASM1233D-15F	4.125	15%	350 ms	◆	LOW	3L TO-92	ASM1233D-15F
ASM1233DZ-5F	4.625	5%	350 ms	◆	LOW	4L SOT-223	KSLL
ASM1233DZ-10F	4.375	10%	350 ms	◆	LOW	4L SOT-223	KTLL
ASM1233DZ-15F	4.125	15%	350 ms	◆	LOW	4L SOT-223	KULL
ASM1233M-5F	4.375	5%	350 ms	◆	LOW	3L TO-92	ASM1233M-5F
ASM1233M-55F	4.625	10%	350 ms	◆	LOW	3L TO-92	ASM1233M-55F
ASM1233M-3F	2.72	15%	350 ms	◆	LOW	3L TO-92	ASM1233M-3F
ASM1233MS-5F	4.38	5%	350 ms	◆	LOW	8L SOIC	ASM1233MS-5F
ASM1233MS-55F	4.625	10%	350 ms	◆	LOW	8L SOIC	ASM1233MS-55F
ASM1233MS-3F	2.72	15%	350 ms	◆	LOW	8L SOIC	ASM1233MS-3F

ASM1233D, ASM1233D-L, ASM1233M

ON Semiconductor and  are registered trademarks of Semiconductor Components Industries, LLC (SCILLC). SCILLC reserves the right to make changes without further notice to any products herein. SCILLC makes no warranty, representation or guarantee regarding the suitability of its products for any particular purpose, nor does SCILLC assume any liability arising out of the application or use of any product or circuit, and specifically disclaims any and all liability, including without limitation special, consequential or incidental damages. "Typical" parameters which may be provided in SCILLC data sheets and/or specifications can and do vary in different applications and actual performance may vary over time. All operating parameters, including "Typicals" must be validated for each customer application by customer's technical experts. SCILLC does not convey any license under its patent rights nor the rights of others. SCILLC products are not designed, intended, or authorized for use as components in systems intended for surgical implant into the body, or other applications intended to support or sustain life, or for any other application in which the failure of the SCILLC product could create a situation where personal injury or death may occur. Should Buyer purchase or use SCILLC products for any such unintended or unauthorized application, Buyer shall indemnify and hold SCILLC and its officers, employees, subsidiaries, affiliates, and distributors harmless against all claims, costs, damages, and expenses, and reasonable attorney fees arising out of, directly or indirectly, any claim of personal injury or death associated with such unintended or unauthorized use, even if such claim alleges that SCILLC was negligent regarding the design or manufacture of the part. SCILLC is an Equal Opportunity/Affirmative Action Employer. This literature is subject to all applicable copyright laws and is not for resale in any manner.

PUBLICATION ORDERING INFORMATION

LITERATURE FULFILLMENT:

Literature Distribution Center for ON Semiconductor
P.O. Box 5163, Denver, Colorado 80217 USA
Phone: 303-675-2175 or 800-344-3860 Toll Free USA/Canada
Fax: 303-675-2176 or 800-344-3867 Toll Free USA/Canada
Email: orderlit@onsemi.com

N. American Technical Support: 800-282-9855 Toll Free
USA/Canada
Europe, Middle East and Africa Technical Support:
Phone: 421 33 790 2910
Japan Customer Focus Center
Phone: 81-3-5773-3850

ON Semiconductor Website: www.onsemi.com

Order Literature: <http://www.onsemi.com/orderlit>

For additional information, please contact your local
Sales Representative