

# EFC2J017NUZ

## Power MOSFET for 1-Cell Lithium-ion Battery Protection 12 V, 3.2 mΩ, 27 A, Dual N-Channel



ON Semiconductor®

www.onsemi.com

This Power MOSFET features a low on-state resistance. This device is suitable for applications such as power switches of portable machines. Best suited for 1-cell lithium-ion battery applications.

### Features

- 2.5 V drive
- 2 kV ESD HBM
- Common-Drain Type
- ESD Diode-Protected Gate
- Pb-Free, Halogen Free and RoHS compliance

### Applications

- 1-Cell Lithium-ion Battery Charging and Discharging Switch

### SPECIFICATIONS

#### ABSOLUTE MAXIMUM RATINGS at Ta = 25°C (Note 1)

Parameter	Symbol	Value	Unit
Source to Source Voltage	V <sub>SSS</sub>	12	V
Gate to Source Voltage	V <sub>GSS</sub>	±8	V
Maximum Operating Gate to Source Voltage (Note2)	V <sub>GSS(OP)</sub>	±6.4	V
Source Current (DC)	I <sub>S</sub>	27	A
Source Current (Pulse) PW ≤ 100 μs, duty cycle ≤ 1%	I <sub>SP</sub>	100	A
Total Dissipation (Note 3)	P <sub>T</sub>	2.5	W
Junction Temperature	T <sub>j</sub>	150	°C
Storage Temperature	T <sub>stg</sub>	-55 to +150	°C

Note 1 : Stresses exceeding those listed in the Maximum Ratings table may damage the device. If any of these limits are exceeded, device functionality should not be assumed, damage may occur and reliability may be affected.

Note 2 : Functional operation above the stresses listed in the recommended operating ranges is not implied. Extended exposure to stresses beyond the recommended operating ranges limits may affect device reliability.

### THERMAL RESISTANCE RATINGS

Parameter	Symbol	Value	Unit
Junction to Ambient (Note 3)	R <sub>θJA</sub>	50	°C/W

Note 3 : Surface mounted on ceramic substrate (5000 mm<sup>2</sup> × 0.8 mm).

V <sub>SSS</sub>	R <sub>SS(on)</sub> Max	I <sub>S</sub> Max
12 V	3.2 mΩ @ 4.5 V	27 A
	3.4 mΩ @ 3.8 V	
	4.4 mΩ @ 3.1 V	
	6.3 mΩ @ 2.5 V	

### ELECTRICAL CONNECTION N-Channel

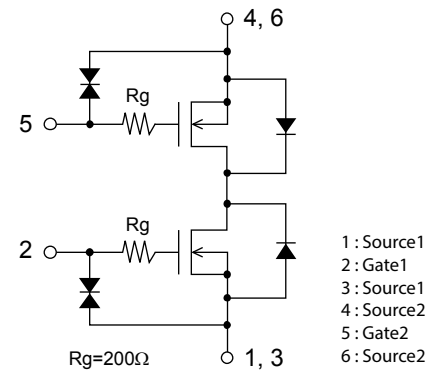

### MARKING



WLCSP6, 1.77x3.05

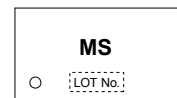

MS : Device Code

### ORDERING INFORMATION

See detailed ordering and shipping information on page 6 of this data sheet.

# EFC2J017NUZ

## ELECTRICAL CHARACTERISTICS at Ta = 25°C (Notes 4, 5)

Parameter	Symbol	Conditions	Value			Unit
			min	typ	max	
Source to Source Breakdown Voltage	V(BR)SSS	IS = 1 mA, VGS = 0 V Test Circuit 1	12			V
Zero-Gate Voltage Source Current	ISSS	VSS = 10 V, VGS = 0 V Test Circuit 1			1	μA
Gate to Source Leakage Current	IGSS	VGS = ±8 V, VSS = 0 V Test Circuit 2			±1	μA
Gate Threshold Voltage	VGS(th)	VSS = 6 V, IS = 1 mA Test Circuit 3	0.5		1.3	V
Static Source to Source On-State Resistance	RSS(on)	IS = 5 A, VGS = 4.5 V Test Circuit 4	1.8	2.3	3.2	mΩ
		IS = 5 A, VGS = 3.8 V Test Circuit 4	2.0	2.6	3.4	mΩ
		IS = 5 A, VGS = 3.1 V Test Circuit 4	2.1	3.3	4.4	mΩ
		IS = 5 A, VGS = 2.5 V Test Circuit 4	2.7	4.0	6.3	mΩ
Turn-ON Delay Time	td(on)	VSS = 6 V, VGS = 4.5 V, IS = 3 A Test Circuit 5		450		ns
Rise Time	tr			590		ns
Turn-OFF Delay Time	td(off)			7,600		ns
Fall Time	tf			2,100		ns
Total Gate Charge	Qg	VSS = 6 V, VGS = 4.5 V, IS = 27 A Test Circuit 6		95		nC
Forward Source to Source Voltage	VF(S-S)	IS = 3 A, VGS = 0 V Test Circuit 7		0.68	1.2	V

Note 4 : Product parametric performance is indicated in the Electrical Characteristics for the listed test conditions, unless otherwise noted. Product performance may not be indicated by the Electrical Characteristics if operated under different conditions.

Note 5 : Refer to the JIS 7030 measuring methods for transistors for measuring.

Test circuits are example of measuring FET1 side

Test Circuit 1  
 $V_{(BR)SSS} / I_{SSS}$

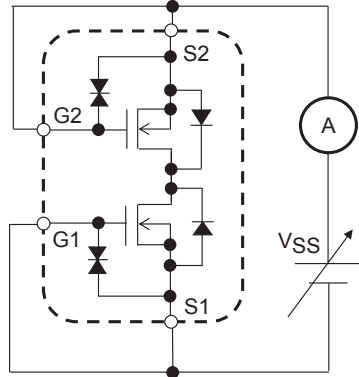

Test Circuit 2  
 $I_{GSS}$

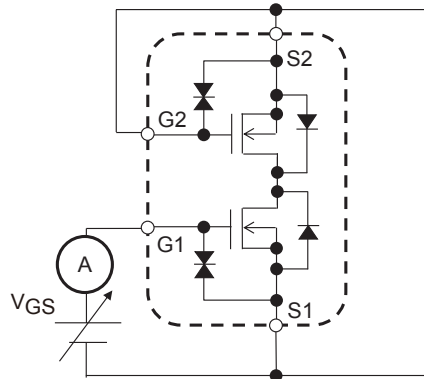

When FET1 is measured, Gate and Source of FET2 are short-circuited.

Test Circuit 3  
 $V_{GS(th)}$

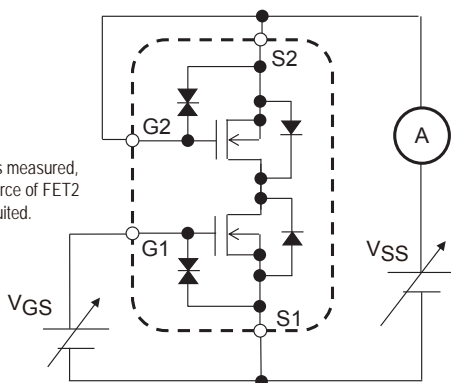

When FET1 is measured, Gate and Source of FET2 are short-circuited.

Test Circuit 4  
 $R_{SS(on)}$

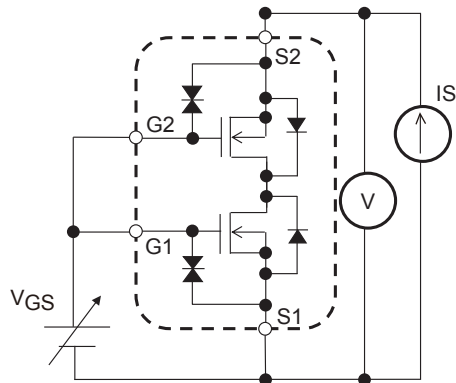

Test Circuit 5  
 $t_d(on), t_r, t_d(off), t_f$

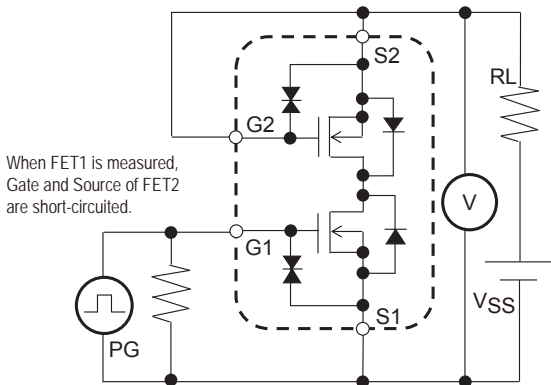

When FET1 is measured, Gate and Source of FET2 are short-circuited.

Test Circuit 6  
 $Q_g$

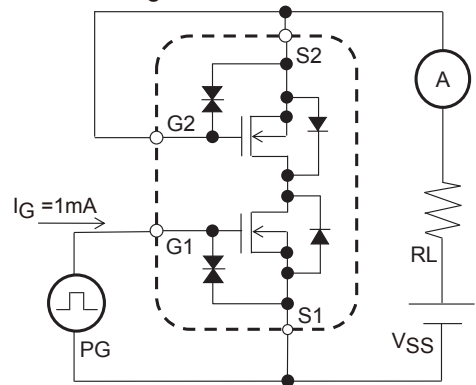

When FET1 is measured, Gate and Source of FET2 are short-circuited.

Test Circuit 7  
 $V_F(S-S)$

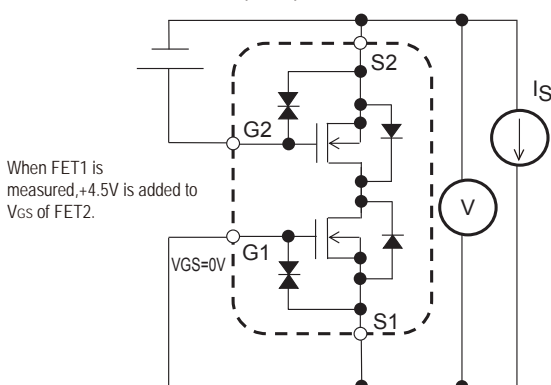

When FET1 is measured, +4.5V is added to  $V_{GS}$  of FET2.

When FET2 is measured, the position of FET1 and FET2 is switched.

# EFC2J017NUZ

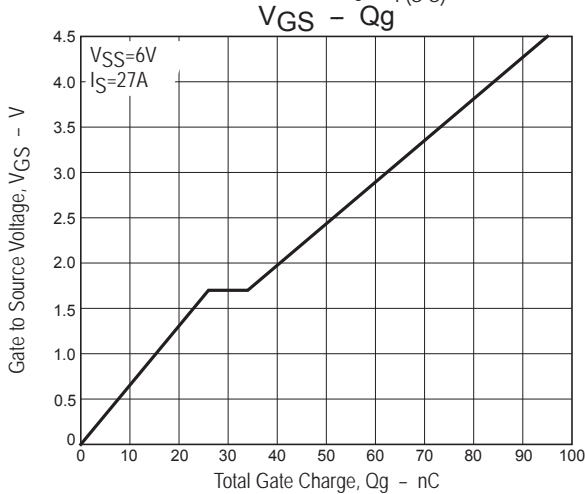
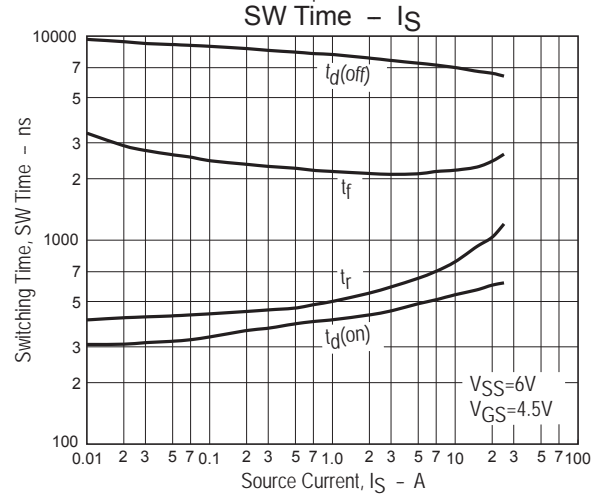
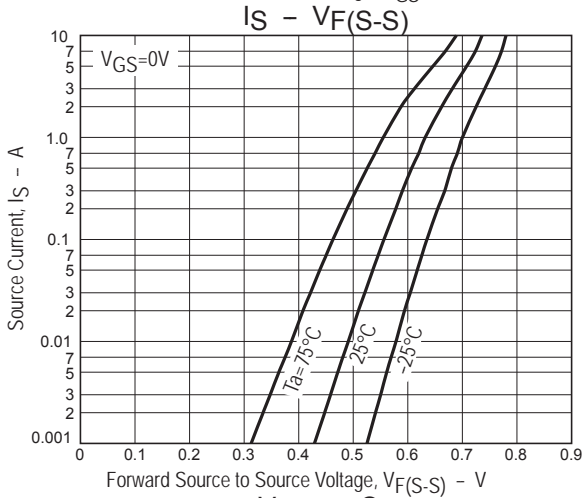
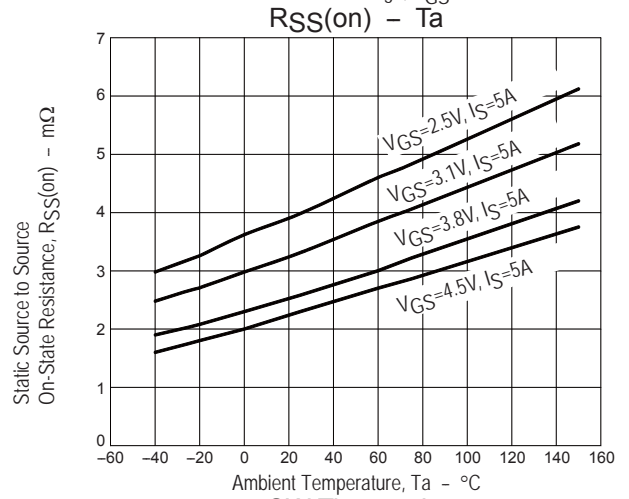
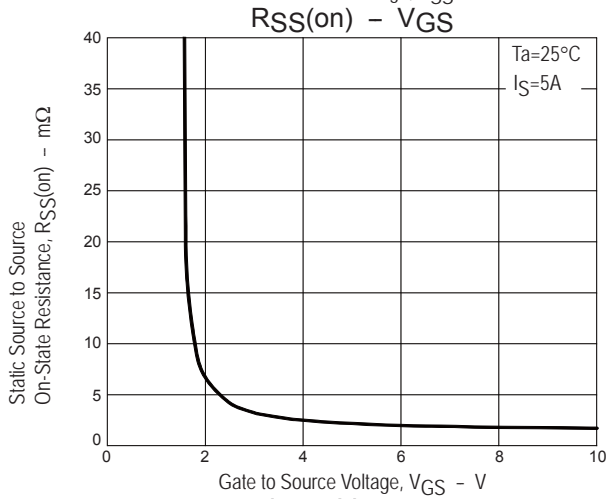
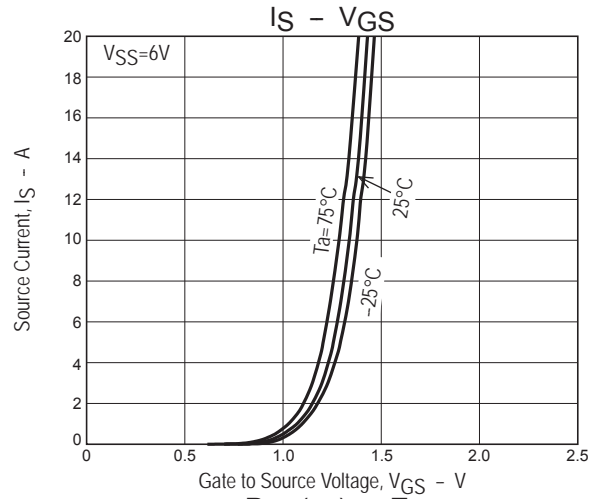
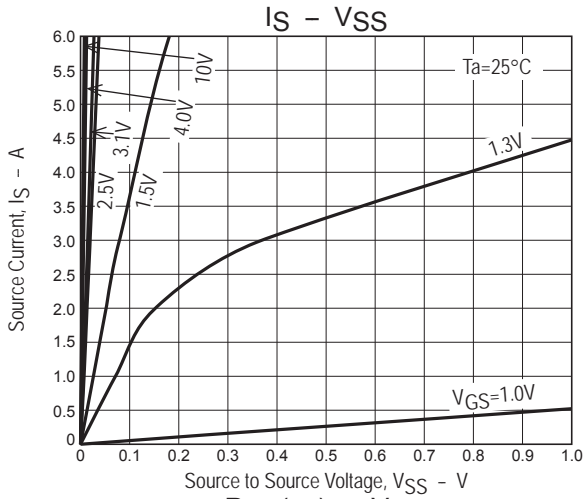

# EFC2J017NUZ

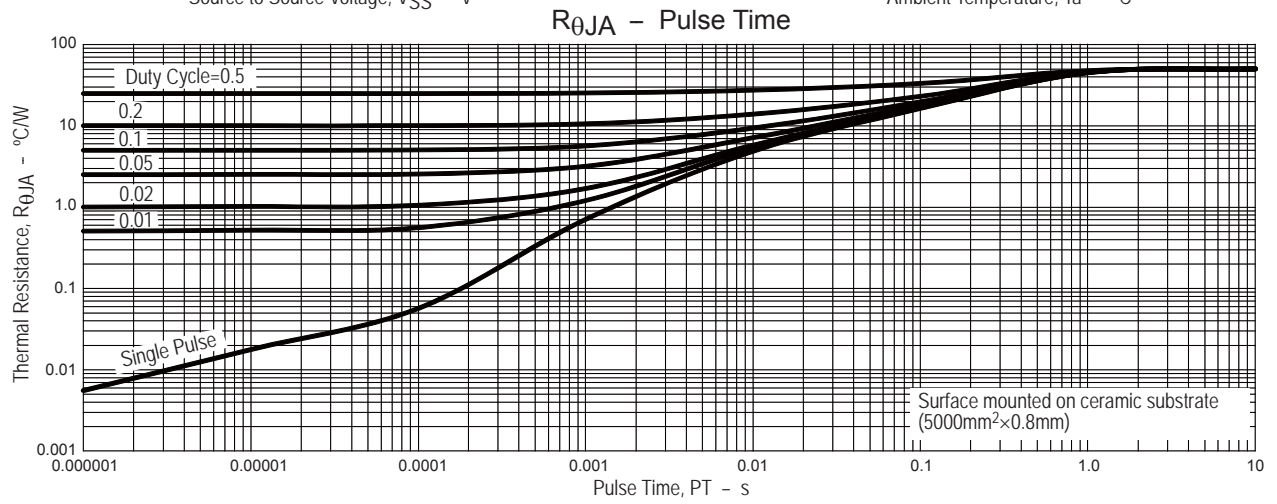
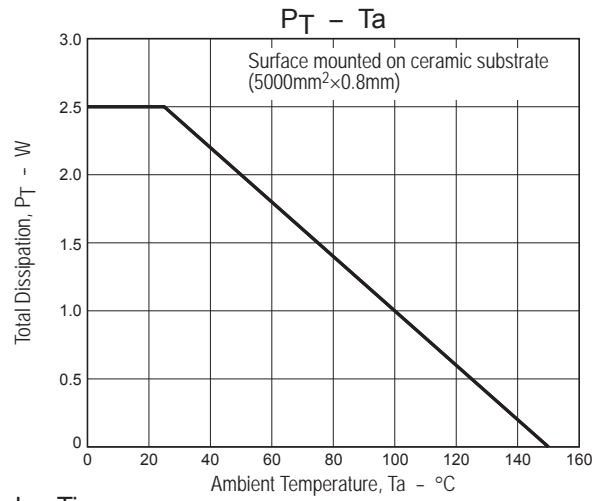
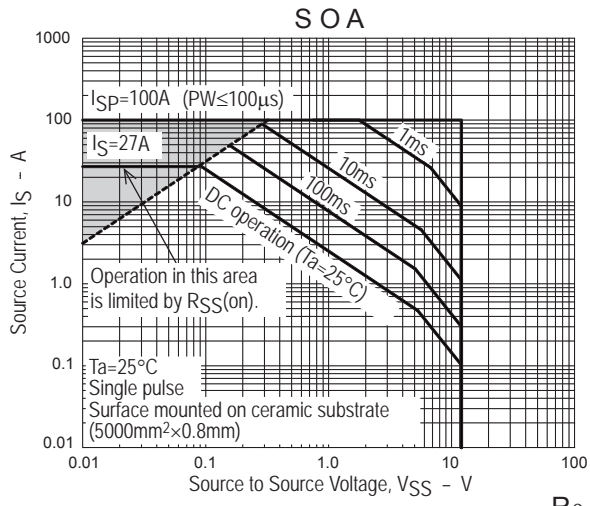

# EFC2J017NUZ

## PACKAGE DIMENSIONS

unit : mm

WLCSP6, 1.77x3.05

CASE 567KS

ISSUE O

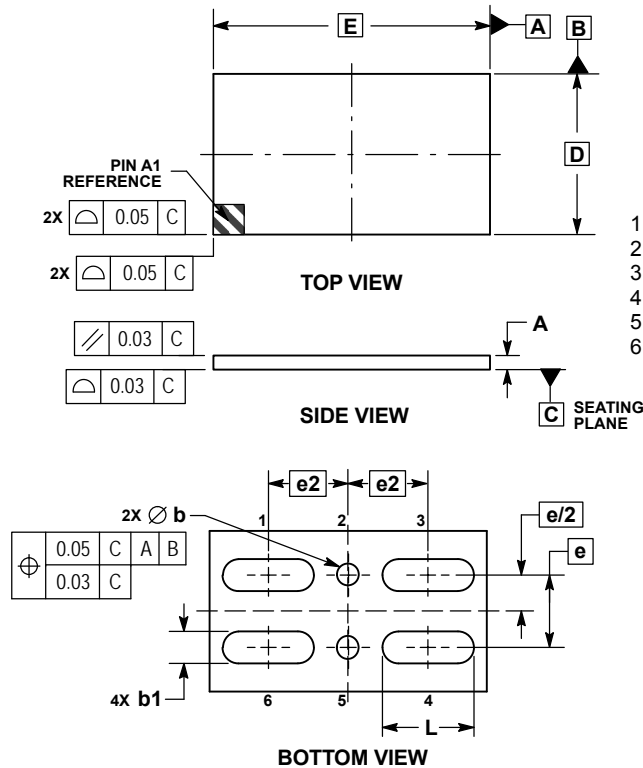

### NOTES:

1. DIMENSIONING AND TOLERANCING PER ASME Y14.5M, 1994.
2. CONTROLLING DIMENSION: MILLIMETERS.

DIM	MILLIMETERS	
	MIN	MAX
A	---	0.145
b	0.22	0.28
b1	0.32	0.38
D	1.77 BSC	
E	3.05 BSC	
e	0.80 BSC	
e2	0.8775 BSC	
L	0.975	1.035

### RECOMMENDED SOLDERING FOOTPRINT\*

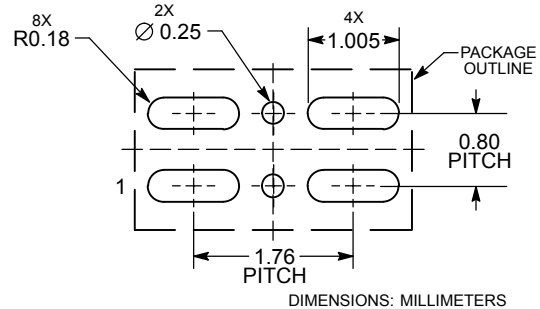

\*For additional information on our Pb-Free strategy and soldering details, please download the ON Semiconductor Soldering and Mounting Techniques Reference Manual, SOLDERRM/D.

## ORDERING INFORMATION

Device	Marking	Package	Shipping (Qty / Packing)
EFC2J017NUZTDG	MS	WLCSP6, 1.77 x 3.05 (Pb-Free / Halogen Free)	5,000 / Tape & Reel

† For information on tape and reel specifications, including part orientation and tape sizes, please refer to our Tape and Reel Packaging Specifications Brochure, BRD8011/D. [http://www.onsemi.com/pub\\_link/Collateral/BRD8011-D.PDF](http://www.onsemi.com/pub_link/Collateral/BRD8011-D.PDF)

Note on usage : Since the EFC2J017NUZ is a MOSFET product, please avoid using this device in the vicinity of highly charged objects. Please contact sales for use except the designated application.

ON Semiconductor and the ON Semiconductor logo are trademarks of Semiconductor Components Industries, LLC dba ON Semiconductor or its subsidiaries in the United States and/or other countries. ON Semiconductor owns the rights to a number of patents, trademarks, copyrights, trade secrets, and other intellectual property. A listing of ON Semiconductor's product/patent coverage may be accessed at [www.onsemi.com/site/pdf/Patent-Marking.pdf](http://www.onsemi.com/site/pdf/Patent-Marking.pdf). ON Semiconductor reserves the right to make changes without further notice to any products herein. ON Semiconductor makes no warranty, representation or guarantee regarding the suitability of its products for any particular purpose, nor does ON Semiconductor assume any liability arising out of the application or use of any product or circuit, and specifically disclaims any and all liability, including without limitation special, consequential or incidental damages. Buyer is responsible for its products and applications using ON Semiconductor products, including compliance with all laws, regulations and safety requirements or standards, regardless of any support or applications information provided by ON Semiconductor. "Typical" parameters which may be provided in ON Semiconductor data sheets and/or specifications can and do vary in different applications and actual performance may vary over time. All operating parameters, including "Typicals" must be validated for each customer application by customer's technical experts. ON Semiconductor does not convey any license under its patent rights nor the rights of others. ON Semiconductor products are not designed, intended, or authorized for use as a critical component in life support systems or any FDA Class 3 medical devices or medical devices with a same or similar classification in a foreign jurisdiction or any devices intended for implantation in the human body. Should Buyer purchase or use ON Semiconductor products for any such unintended or unauthorized application, Buyer shall indemnify and hold ON Semiconductor and its officers, employees, subsidiaries, affiliates, and distributors harmless against all claims, costs, damages, and expenses, and reasonable attorney fees arising out of, directly or indirectly, any claim of personal injury or death associated with such unintended or unauthorized use, even if such claim alleges that ON Semiconductor was negligent regarding the design or manufacture of the part. ON Semiconductor is an Equal Opportunity/Affirmative Action Employer. This literature is subject to all applicable copyright laws and is not for resale in any manner.