

16-Bit to 32-Bit Multiplexer/ Demultiplexer Bus Switch with -2 V Undershoot Protection



ON Semiconductor®

www.onsemi.com

FSTU32160

General Description

The ON Semiconductor Switch FSTU32160 is a 16-bit to 32-bit highspeed CMOS TTL-compatible multiplexer/demultiplexer bus switch. The low on resistance of the switch allows inputs to be connected to outputs without adding propagation delay or generating additional ground bounce noise.

The device can be used in applications where two buses need to be addressed simultaneously. The FSTU32160 is designed so that the A Port demultiplexes into B₁ or B₂ or both. The A and B Ports have “undershoot hardened” circuit protection to support an extended range to 2.0 V below ground. The integrated Undershoot Hardened Circuit senses undershoot at the I/O’s, and responds by preventing voltage differentials from developing and turning on the switch.

Two select (S₁, S₂) inputs provide switch enable control. When S₁, S₂ are HIGH, the device precharges the B Port to a selectable bias voltage (Bias V) to minimize live insertion noise.

Features

- Undershoot hardened to -2 V (A and B Ports)
- Slower Output Enable Times prevent Signal Disruption
- 4 Ω Switch Connection between Two Ports
- Minimal Propagation Delay through the Switch
- Low I_{CC}
- Zero Bounce in Flow-through Mode
- Control Inputs Compatible with TTL Level
- See Application Note AN-5008 for Details
- This Device is Pb-Free and is RoHS Compliant

PIN DESCRIPTIONS

Pin Name	Description
S ₁ , S ₂	Select Inputs
A	Bus A
B ₁ , B ₂	Bus B

TRUTH TABLE

Inputs		Function
S ₁	S ₂	
L	H	x A = x B ₁
H	L	x A = x B ₂
L	L	x A = x B ₁ and x B ₂
H	H	x B ₁ , x B ₂ = BiasV

TSSOP56 14x6.1
CASE 948BR

CONNECTION DIAGRAM

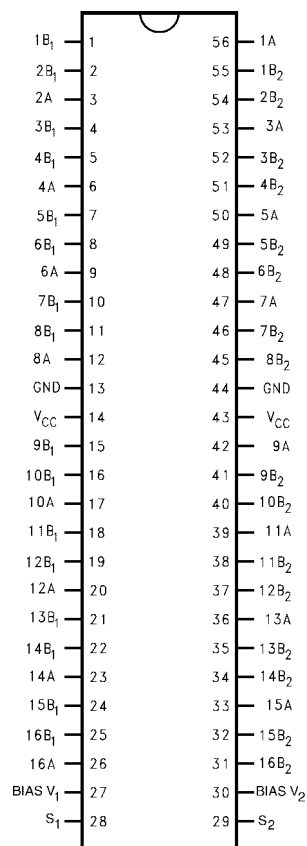

ORDERING INFORMATION

See detailed ordering and shipping information on page 2 of this data sheet.

FSTU32160

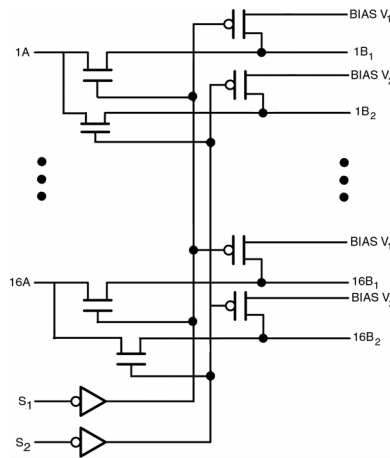

Figure 1. Logic Diagram

ABSOLUTE MAXIMUM RATINGS

Parameter	Symbol	Conditions	Rating	Units
Supply Voltage	V _{CC}		-0.5 to 7.0	V
DC Switch Voltage	V _S	Note 1	-2.0 to 7.0	V
BiasV Voltage Range			-0.5 to 7.0	V
DC Input Control Pin Voltage	V _{IN}	Note 2	-0.5 to 7.0	V
DC Input Diode Current	I _{IK}	V _{IN} < 0 V	-50	mA
DC Output Current	I _{OUT}		128	mA
DC V _{CC} /GND Current	I _{CC} /I _{GND}		±100	mA
Storage Temperature Range	T _{STG}		-65 to 150	°C

Stresses exceeding those listed in the Maximum Ratings table may damage the device. If any of these limits are exceeded, device functionality should not be assumed, damage may occur and reliability may be affected.

1. V_S is the voltage observed/applied at either the A or B Ports across the switch.
2. The input and output negative voltage ratings may be exceeded if the input and output diode current ratings are observed.

RECOMMENDED OPERATING CONDITIONS (Note 3)

Parameter	Symbol	Conditions	Rating	Units
Power Supply Operating	V _{CC}		4.0 to 5.5	V
Precharge Supply	BiasV		1.5 to V _{CC}	V
Input Voltage	V _{IN}		0 to 5.5	V
Output Voltage	V _{OUT}		0 to 5.5	V
Input Rise and Fall Time	t _r /t _f	Switch Control Input	0 to 5	ns/V
		Switch I/O	0 to DC	
Free Air Operating Temperature	T _A		-40 to 85	°C

Functional operation above the stresses listed in the Recommended Operating Ranges is not implied. Extended exposure to stresses beyond the Recommended Operating Ranges limits may affect device reliability.

3. Unused control inputs must be held HIGH or LOW. They may not float.

ORDERING INFORMATION

Part Number	Package	Shipping [†]
FSTU32160MTDX	TSSOP56 14x6.1, JEDEC MO-153, 6.1 mm Wide (Pb-Free)	1000 units / Tape & Reel

[†]For information on tape and reel specifications, including part orientation and tape sizes, please refer to our Tape and Reel Packaging Specifications Brochure, BRD8011/D

FSTU32160

DC ELECTRICAL CHARACTERISTICS

Symbol	Parameter	V _{CC} (V)	T _A = -40 °C to +85 °C			Units	Conditions
			Min	Typ (Note 4)	Max		
V _{IK}	Clamp Diode Voltage	4.5			-1.2	V	I _{IN} = -18 mA
V _{IH}	HIGH Level Input Voltage	4.0-5.5	2.0			V	
V _{IL}	LOW Level Input Voltage	4.0-5.5			0.8	V	
I _I	Input Leakage Current	5.5			±1.0	μA	0 ≤ V _{IN} ≤ 5.5 V
		0			10	μA	V _{IN} = 5.5 V
I _O	Output Current	4.5	0.25			mA	BiasV = 2.4 V, S _X = 2.0 V B _X = 0
I _{OZH} , I _{OZL}	OFF-STATE Leakage Current	5.5			±1.0	μA	0 ≤ A, ≤ V _{CC} , V BiasV ₁ = BiasV ₂ = 5.5 V
I _{OZH} , I _{OZL}	OFF-STATE Leakage Current	5.5			±1.0	μA	0 ≤ B, ≤ V _{CC} , V BiasV ₁ = BiasV ₂ = FLOATING
R _{ON}	Switch On Resistance (Note 5)	4.5		4	7	Ω	V _{IN} = 0 V, I _{IN} = 64 mA
		4.5		4	7	Ω	V _{IN} = 0 V, I _{IN} = 30 mA
		4.5		8	14	Ω	V _{IN} = 2.4 V, I _{IN} = 15 mA
		4.0		11	20	Ω	V _{IN} = 2.4 V, I _{IN} = 15 mA
I _{CC}	Quiescent Supply Current	5.5			3	μA	V _{IN} = V _{CC} or GND, I _{OUT} = 0
Δ I _{CC}	Increase in I _{CC} per Input	5.5			2.5	mA	One input at 3.4 V Other inputs at V _{CC} or GND
I _{BIAS}	Bias Pin Leakage Current	5.5			±1.0	μA	S ₁ , S ₂ = 0 V B _X = 0 V, BiasV _X = 5.5 V
V _{IKU}	Voltage Undershoot	5.5			-2.0	V	0.0 mA ≥ I _{IN} ≥ -50 mA S ₁ , S ₂ = 5.5 V

4. Typical values are at V_{CC} = 5.0 V and T_A = +25 °C

5. Measured by the voltage drop between A and B pins at the indicated current through the switch. On resistance is determined by the lower of the voltages on the two (A or B) pins.

AC ELECTRICAL CHARACTERISTICS

Symbol	Parameter	T _A = -40 °C to +85 °C, C _L = 50 pF, R _U = R _D = 500 Ω				Units	Conditions	Figure No.
		V _{CC} = 4.5 - 5.5 V		V _{CC} = 4.0 V				
		Min	Max	Min	Max			
t _{PHL} , t _{PLH}	A or B, to B or A (Note 6)		0.25		0.25	ns	V _I = OPEN	Figures 4, 5
t _{PZH}	Output Enable Time, S to A, B	7.0	30.0		35.0	ns	V _I = OPEN for t _{PZH} BiasV = GND	Figures 4, 5
t _{PZL}	Output Enable Time, S to A, B	7.0	30.0		35.0	ns	V _I = 7 V for t _{PZL} BiasV = 3 V	Figures 4, 5
t _{PHZ}	Output Disable Time, S to A, B	1.0	6.9		7.3	ns	V _I = OPEN for t _{PHZ} BiasV = GND	Figures 4, 5
t _{PLZ}	Output Disable Time, S to A, B	1.0	7.7		7.7	ns	V _I = 7 V for t _{PLZ} BiasV = 3 V	Figures 4, 5

6. This parameter is guaranteed by design but is not tested. The bus switch contributes no propagation delay other than the RC delay of the typical On resistance of the switch and the 50 pF load capacitance, when driven by an ideal voltage source (zero output impedance).

FSTU32160

CAPACITANCE (Note 7)

Symbol	Parameter	Typ	Max	Units	Conditions
C_{IN}	Control pin Input Capacitance	4		pF	$V_{CC} = 5.0\text{ V}$
$C_{I/O\ OFF}$	Input/Output Capacitance "OFF State"	8		pF	$V_{CC} = 5.0\text{ V}$, Switch OFF

7. $T_A = +25^\circ\text{C}$, $f = 1\text{ MHz}$, Capacitance is characterized but not tested.

UNDERSHOOT CHARACTERISTIC (Note 8)

Symbol	Parameter	Min	Typ	Max	Units	Conditions
V_{OUTU}	Output Voltage During Undershoot	2.5	$V_{OH} - 0.3$		V	Figure 2

8. This test is intended to characterize the device's protective capabilities by maintaining output signal integrity during an input transient voltage undershoot event.

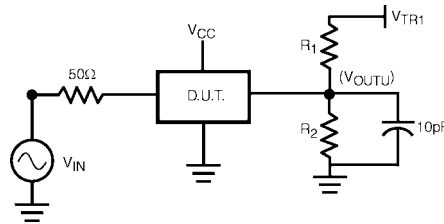

Figure 2.

DEVICE TEST CONDITIONS

Parameter	Value	Units
V_{IN}	see Waveform	V
$R_1 = R_2$	100K	Ω
V_{TRI}	11.0	V
V_{CC}	5.5	V

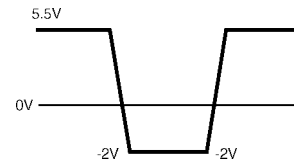
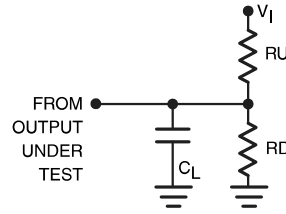

Figure 3. Transient Input Voltage (V_{IN}) Waveform

AC Loading and Waveforms



Notes:

Input driven by 50 Ω source terminated in 50 Ω.
 C_L includes load and stray capacitance, $C_L = 50$ pF
 Input PRR = 1.0 MHz, $t_W = 500$ ns

Figure 4. AC Test Circuit

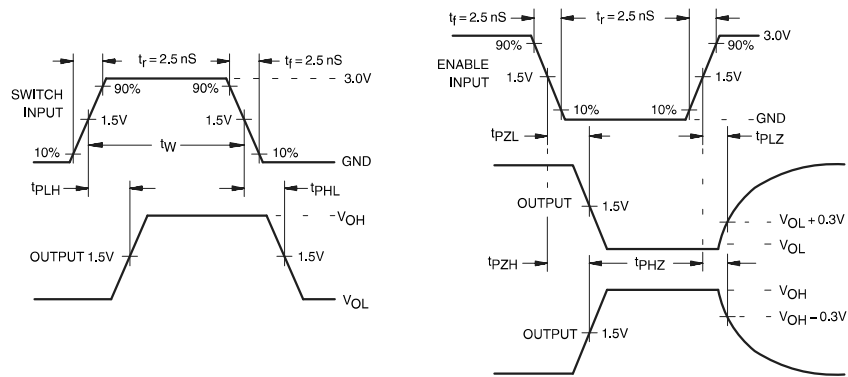

Figure 5. AC Waveforms

MECHANICAL CASE OUTLINE

PACKAGE DIMENSIONS

ON Semiconductor®



TSSOP56 14x6.1
CASE 948BR
ISSUE O

DATE 30 SEP 2016

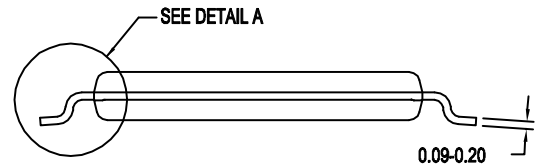
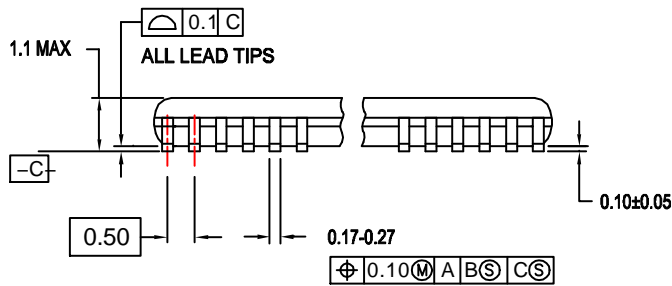
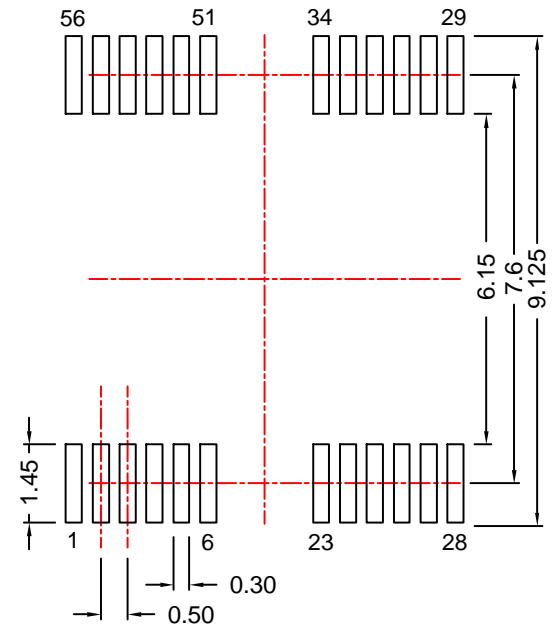
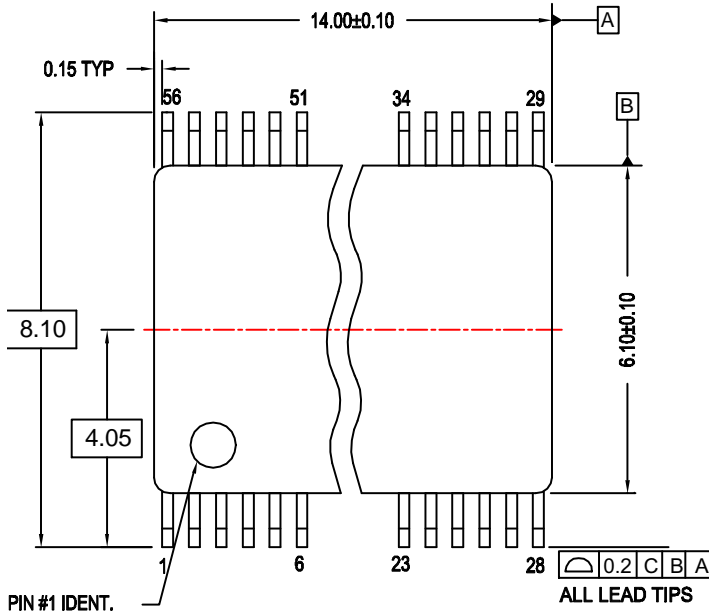

NOTES:

- A. CONFORMS TO JEDEC REGISTRATION MO-153, VARIATION EE, REF NOTE 6, DATE 10/97.
- B. DIMENSIONS ARE IN MILLIMETERS.
- C. DIMENSIONS ARE EXCLUSIVE OF BURRS, MOLD FLASH, AND TIE BAR EXTRUSIONS.
- D. DIMENSIONS AND TOLERANCES PER ANSI Y14.5M, 1982.

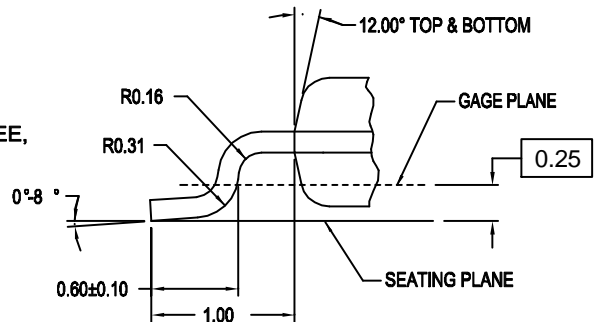

DETAIL A

DOCUMENT NUMBER:	98AON13776G	Electronic versions are uncontrolled except when accessed directly from the Document Repository. Printed versions are uncontrolled except when stamped "CONTROLLED COPY" in red.
STATUS:	ON SEMICONDUCTOR STANDARD	
NEW STANDARD:		
DESCRIPTION:	TSSOP56 14X6.1	PAGE 1 OF 2

ON Semiconductor and  are trademarks of Semiconductor Components Industries, LLC dba ON Semiconductor or its subsidiaries in the United States and/or other countries. ON Semiconductor owns the rights to a number of patents, trademarks, copyrights, trade secrets, and other intellectual property. A listing of ON Semiconductor's product/patent coverage may be accessed at www.onsemi.com/site/pdf/Patent-Marking.pdf. ON Semiconductor reserves the right to make changes without further notice to any products herein. ON Semiconductor makes no warranty, representation or guarantee regarding the suitability of its products for any particular purpose, nor does ON Semiconductor assume any liability arising out of the application or use of any product or circuit, and specifically disclaims any and all liability, including without limitation special, consequential or incidental damages. Buyer is responsible for its products and applications using ON Semiconductor products, including compliance with all laws, regulations and safety requirements or standards, regardless of any support or applications information provided by ON Semiconductor. "Typical" parameters which may be provided in ON Semiconductor data sheets and/or specifications can and do vary in different applications and actual performance may vary over time. All operating parameters, including "Typicals" must be validated for each customer application by customer's technical experts. ON Semiconductor does not convey any license under its patent rights nor the rights of others. ON Semiconductor products are not designed, intended, or authorized for use as a critical component in life support systems or any FDA Class 3 medical devices or medical devices with a same or similar classification in a foreign jurisdiction or any devices intended for implantation in the human body. Should Buyer purchase or use ON Semiconductor products for any such unintended or unauthorized application, Buyer shall indemnify and hold ON Semiconductor and its officers, employees, subsidiaries, affiliates, and distributors harmless against all claims, costs, damages, and expenses, and reasonable attorney fees arising out of, directly or indirectly, any claim of personal injury or death associated with such unintended or unauthorized use, even if such claim alleges that ON Semiconductor was negligent regarding the design or manufacture of the part. ON Semiconductor is an Equal Opportunity/Affirmative Action Employer. This literature is subject to all applicable copyright laws and is not for resale in any manner.

PUBLICATION ORDERING INFORMATION

LITERATURE FULFILLMENT:

Literature Distribution Center for ON Semiconductor
19521 E. 32nd Pkwy, Aurora, Colorado 80011 USA
Phone: 303-675-2175 or 800-344-3860 Toll Free USA/Canada
Fax: 303-675-2176 or 800-344-3867 Toll Free USA/Canada
Email: orderlit@onsemi.com

N. American Technical Support: 800-282-9855 Toll Free
USA/Canada
Europe, Middle East and Africa Technical Support:
Phone: 421 33 790 2910

ON Semiconductor Website: www.onsemi.com

Order Literature: <http://www.onsemi.com/orderlit>

For additional information, please contact your local
Sales Representative