

MC33263

Product Preview

Ultra Low Noise 150 mA Low Dropout Voltage Regulator with ON/OFF Control



ON Semiconductor®

<http://onsemi.com>

Housed in a Micro8™ or QFN6 package, the MC33263 delivers up to 150 mA where it exhibits a typical 180 mV dropout. With an incredible noise level of 25 μ V_{RMS} (over 100 Hz to 100 kHz, with a 10 nF bypass capacitor), the MC33263 represents the ideal choice for sensitive circuits, especially in portable applications where noise performance and space are premium. The MC33263 also excels in response time and reacts in less than 25 μ s when receiving an OFF to ON signal (with no bypass capacitor).

Due to a novel concept, the MC33263 accepts output capacitors without any restrictions regarding their Equivalent Series Resistance (ESR) thus offering an obvious versatility for immediate implementation.

With a typical DC ripple rejection better than -90 dB (-70 dB @ 1.0 kHz), it naturally shields the downstream electronics against choppy power lines.

Additionally, thermal shutdown and short-circuit protection provide the final product with a high degree of ruggedness.

Features:

- Very Low Quiescent Current 170 μ A (ON, no load), 100 nA (OFF, no load)
- Very Low Dropout Voltage, Typical Value is 137 mV at an Output Current of 100 mA
- Very Low Noise with External Bypass Capacitor (10 nF), Typically 25 μ V_{rms} over 100 Hz to 100 kHz
- Internal Thermal Shutdown
- Extremely Tight Line Regulation Typically -90 dB
- Ripple Rejection -70 dB @ 1.0 kHz
- Line Transient Response: 1.0 mV for $\Delta V_{in} = 3.0$ V
- Extremely Tight Load Regulation, Typically 20 mV at $\Delta I_{out} = 150$ mA
- Multiple Output Voltages Available
- Logic Level ON/OFF Control (TTL-CMOS Compatible)
- ESR can vary from 0 to 3.0 Ω

Applications:

- All Portable Systems, Battery Powered Systems, Cellular Telephones, Radio Control Systems, Toys and Low Voltage Systems

This document contains information on a product under development. ON Semiconductor reserves the right to change or discontinue this product without notice.

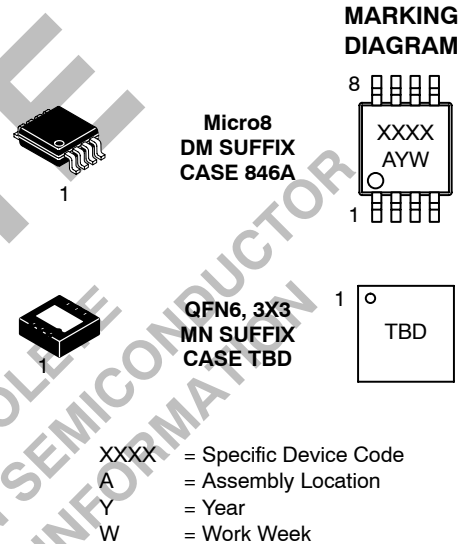

PIN CONNECTIONS

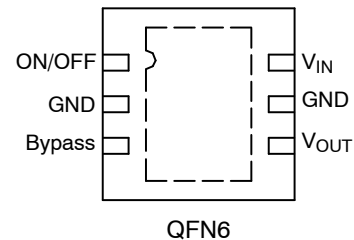
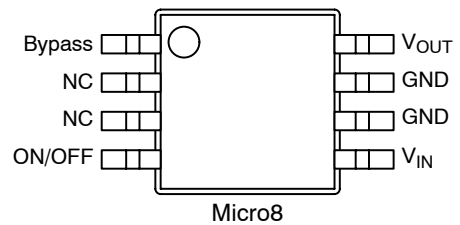

ORDERING INFORMATION

See detailed ordering and shipping information on page 12 of this data sheet.

MC33263

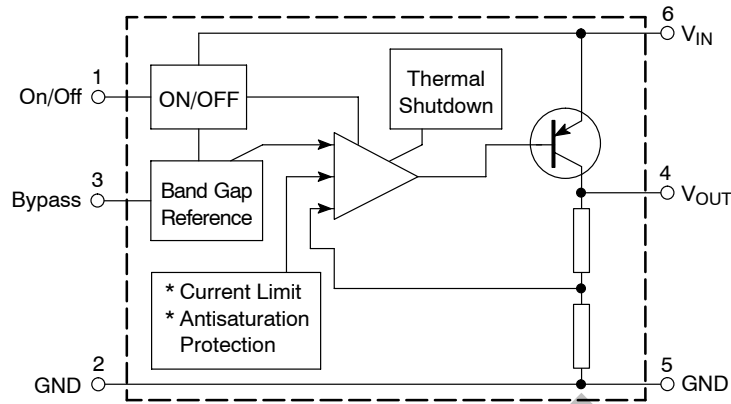

Figure 1. MC33263 Block Diagram for the QFN6

MAXIMUM RATINGS

Rating	Symbol	Pin #	Value	Unit
Power Supply Voltage	V_{in}	6	12	V
Power Dissipation and Thermal Resistance Maximum Power Dissipation Thermal Resistance, Junction-to-Air	P_D $R_{\theta JA}$		Internally Limited 210	W °C/W
Operating Ambient Temperature Maximum Junction Temperature	T_A T_{Jmax}		-40 to +85 150	°C °C
Storage Temperature Range	T_{stg}		-60 to +150	°C

ELECTRICAL CHARACTERISTICS (For typical values $T_A = 25^\circ\text{C}$, for min/max values $T_A = -40^\circ\text{C}$ to $+85^\circ\text{C}$, Max $T_J = 150^\circ\text{C}$)

Characteristics	Symbol	Pin #	Min	Typ	Max	Unit
-----------------	--------	-------	-----	-----	-----	------

CONTROL ELECTRICAL CHARACTERISTICS

Input Voltage Range	$V_{ON/OFF}$	1	0	-	V_{in}	V
ON/OFF Input Current (All versions) $V_{ON/OFF} = 2.4\text{ V}$	$I_{ON/OFF}$	1	-	2.5	-	μA
ON/OFF Input Voltages (All versions) Logic "0", i.e. OFF State Logic "1", i.e. ON State	$V_{ON/OFF}$	1	- 2.2	- -	0.3 -	V

CURRENTS PARAMETERS

Current Consumption in OFF State (All versions) OFF Mode Current: $V_{in} = V_{out} + 1.0\text{ V}$, $I_{out} = 0\text{ mA}$	I_{QOFF}		-	0.1	2.0	μA
Current Consumption in ON State (All versions) ON Mode Sat Current: $V_{in} = V_{out} + 1.0\text{ V}$, $I_{out} = 0\text{ mA}$	I_{QON}		-	170	200	μA
Current Consumption in Saturation ON State (All versions) ON Mode Sat Current: $V_{in} = V_{out} - 0.5\text{ V}$, $I_{out} = 0\text{ mA}$	I_{QSAT}		-	900	1400	μA
Current Limit $V_{in} = V_{out} + 1.0\text{ V}$, (All versions) Output Short-circuited (Note 1)	I_{MAX}		175	210	-	mA

1. I_{out} (Output Current) is the measured current when the output voltage drops below 0.3 V with respect to V_{out} at $I_{out} = 30\text{ mA}$.

MC33263

ELECTRICAL CHARACTERISTICS (For typical values $T_A = 25^\circ\text{C}$, for min/max values $T_A = -40^\circ\text{C}$ to $+85^\circ\text{C}$, Max $T_J = 150^\circ\text{C}$)

Characteristics	Symbol	Pin #	Min	Typ	Max	Unit
$V_{in} = V_{out} + 1.0\text{ V}$, $T_A = 25^\circ\text{C}$, $1.0\text{ mA} < I_{out} < 150\text{ mA}$ 3.3 Suffix 5.0 Suffix	V_{out}	4	3.23 4.90	3.3 5.0	3.37 5.1	V
$V_{in} = V_{out} + 1.0\text{ V}$, $-40^\circ\text{C} < T_A < 80^\circ\text{C}$, 3.3 Suffix 5.0 Suffix	V_{out}	4	3.18 4.83	3.3 5.0	3.42 5.17	V

LINE AND LOAD REGULATION, DROPOUT VOLTAGES

Line Regulation (All versions) $V_{out} + 1.0\text{ V} < V_{in} < 12\text{ V}$, $I_{out} = 60\text{ mA}$	Reg_{line}	4/6	-	2.0	10	mV
Load Regulation (All versions) $V_{in} = V_{out} + 1.0\text{ V}$ $I_{out} = 1.0$ to 60 mA $I_{out} = 1.0$ to 100 mA $I_{out} = 1.0$ to 150 mA	Reg_{load}	1	- - -	8.0 15 20	25 35 45	mV
Dropout Voltage (All versions) $I_{out} = 10\text{ mA}$ $I_{out} = 100\text{ mA}$ $I_{out} = 150\text{ mA}$	$V_{in} - V_{out}$	4, 6	- - -	30 137 180	90 230 260	mV

DYNAMIC PARAMETERS

Ripple Rejection (All versions) $V_{in} = V_{out} + 1.0\text{ V}$, $V_{pp} = 1.0\text{ V}$, $f = 1.0\text{ kHz}$, $I_{out} = 60\text{ mA}$		4, 6	60	70	-	dB
Line Transient Response $V_{in} = V_{out} + 1.0\text{ V}$ to $V_{out} + 4.0\text{ V}$, $I_{out} = 60\text{ mA}$, $d(V_{in})/dt = 15\text{ mV}/\mu\text{s}$		4, 6	-	1.0	-	mV
Output Noise Voltage (All versions) $C_{out} = 1.0\text{ }\mu\text{F}$, $I_{out} = 60\text{ mA}$, $f = 100\text{ Hz}$ to 100 kHz $C_{bypass} = 10\text{ nF}$ $C_{bypass} = 1.0\text{ nF}$ $C_{bypass} = 0\text{ nF}$	V_{RMS}	4, 6	- - -	25 40 65	- - -	μV_{rms}
Output Noise Density $C_{out} = 1.0\text{ }\mu\text{F}$, $I_{out} = 60\text{ mA}$, $f = 1.0\text{ kHz}$	V_N	4	-	230	-	$\text{nV}/\sqrt{\text{Hz}}$
Output Rise Time (All versions) $C_{out} = 1.0\text{ }\mu\text{F}$, $I_{out} = 30\text{ mA}$, $V_{ON/OFF} = 0$ to 2.4 V 1% of ON/OFF Signal to 99% of Nominal Output Voltage Without Bypass Capacitor With $C_{bypass} = 10\text{ nF}$	t_r	4	- -	40 1.1	- -	μs ms

THERMAL SHUTDOWN

Thermal Shutdown (All versions)			-	150	-	$^\circ\text{C}$
---------------------------------	--	--	---	-----	---	------------------

DEFINITIONS

Load Regulation – The change in output voltage for a change in load current at constant chip temperature.

Dropout Voltage – The input/output differential at which the regulator output no longer maintains regulation against further reductions in input voltage. Measured when the output drops 100 mV below its nominal value (which is measured at 1.0 V differential), dropout voltage is affected by junction temperature, load current and minimum input supply requirements.

Output Noise Voltage – The RMS AC voltage at the output with a constant load and no input ripple, measured over a specified frequency range.

Maximum Power Dissipation – The maximum total dissipation for which the regulator will operate within specifications.

Quiescent Current – Current which is used to operate the regulator chip and is not delivered to the load.

Line Regulation – The change in input voltage for a change in the input voltage. The measurement is made under conditions of low dissipation or by using pulse techniques such that the average chip temperature is not significantly affected.

Line Transient Response – Typical over- and undershoot response when input voltage is excited with a given slope.

Thermal Protection – Internal thermal shutdown circuitry is provided to protect the integrated circuit in the event that the maximum junction temperature is exceeded. When activated, typically 150°C, the regulator turns off. This feature is provided to prevent catastrophic failures from accidental overheating.

Maximum Package Power Dissipation – The maximum package power dissipation is the power dissipation level at which the junction temperature reaches its maximum value i.e. 125°C. The junction temperature is rising while the difference between the input power ($V_{CC} \times I_{CC}$) and the output power ($V_{out} \times I_{out}$) is increasing.

Depending on ambient temperature, it is possible to calculate the maximum power dissipation, maximum load current or maximum input voltage (see Application Hints: Protection).

The maximum power dissipation supported by the device is a lot increased when using appropriate application design. Mounting pad configuration on the PCB, the board material and also the ambient temperature are affected the rate of temperature rise. It means that when the IC has good thermal conductivity through PCB, the junction temperature will be “low” even if the power dissipation is great.

The thermal resistance of the whole circuit can be evaluated by deliberately activating the thermal shutdown of the circuit (by increasing the output current or raising the input voltage for example).

Then you can calculate the power dissipation by subtracting the output power from the input power. All variables are then well known: power dissipation, thermal shutdown temperature (150°C for MC33263) and ambient temperature.

APPLICATION HINTS

Input Decoupling – As with any regulator, it is necessary to reduce the dynamic impedance of the supply rail that feeds the component. A 1.0 μF capacitor either ceramic or tantalum is recommended and should be connected close to the MC33263 package. Higher values will correspondingly improve the overall line transient response.

Output Decoupling – Due to a novel concept, the MC33263 is a stable component and does not require any Equivalent Series Resistance (ESR) neither a minimum output current. Capacitors exhibiting ESRs ranging from a few mΩ up to 3.0 Ω can thus safely be used. The minimum decoupling value is 1.0 μF and can be augmented to fulfill stringent load transient requirements. The regulator accepts ceramic chip capacitors as well as tantalum devices.

Noise Performances – Unlike other LDOs, the MC33263 is a true low-noise regulator. With a 10 nF bypass capacitor, it typically reaches the incredible level of 25 μVRMS overall noise between 100 Hz and 100 kHz. To give maximum insight on noise specifications, ON Semiconductor includes spectral density graphics as well as noise dependency versus bypass capacitor.

The bypass capacitor impacts the start-up phase of the MC33263 as depicted by the data-sheet curves. A typical 1.0 ms settling time is achieved with a 10 nF bypass capacitor. However, due to its low-noise architecture, the MC33263 can operate without bypass and thus offers a typical 20 μs start-up phase. In that case, the typical output noise stays lower than 65 μVRMS between 100 Hz – 100 kHz.

Protections – The MC33263 hosts several protections, conferring natural ruggedness and reliability to the products implementing the component. The output current is internally limited to a minimum of 175 mA while temperature shutdown occurs if the die heats up beyond 150°C. These value lets you assess the maximum differential voltage the device can sustain at a given output current before its protections come into play.

The maximum dissipation the package can handle is given by:

$$P_{max} = \frac{T_{Jmax} - T_A}{R_{\theta JA}}$$

If T_{Jmax} is internally limited to 150°C, then the MC33263 can dissipate up to 595 mW @ 25°C.

The power dissipated by the MC33263 can be calculated from the following formula:

$$P_{tot} = \langle V_{in} \cdot I_{gnd}(I_{out}) \rangle + \langle V_{in} - V_{out} \rangle \cdot I_{out}$$

or

$$V_{inmax} = \frac{P_{tot} + V_{out} \cdot I_{out}}{I_{gnd} + I_{out}}$$

If a 150 mA output current is needed, the ground current is extracted from the data-sheet curves: 6.5 mA @ 150 mA. For a MC33263NW28R2 (2.8 V), the maximum input voltage will then be 6.48 V, a rather comfortable margin.

Typical Application – The following figure portrays the typical application for the MC33263 where both input/output decoupling capacitors appear.

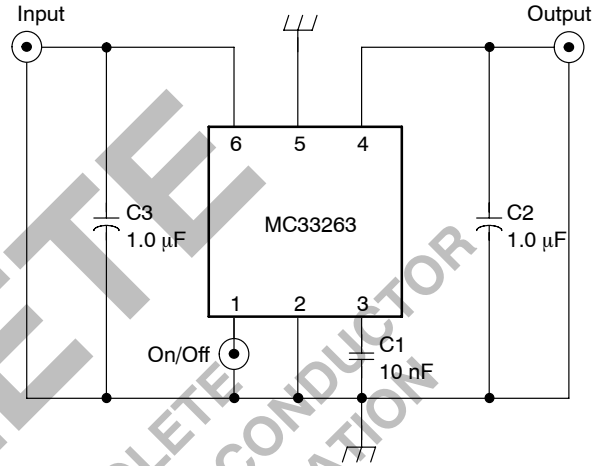

Figure 2. A Typical MC33263 Application with Recommended Capacitor Values (QFN6)

As for any low noise designs, particular care has to be taken when tackling Printed Circuit Board (PCB) layout. The following figure gives an example of a layout where stray inductances/capacitances are minimized.

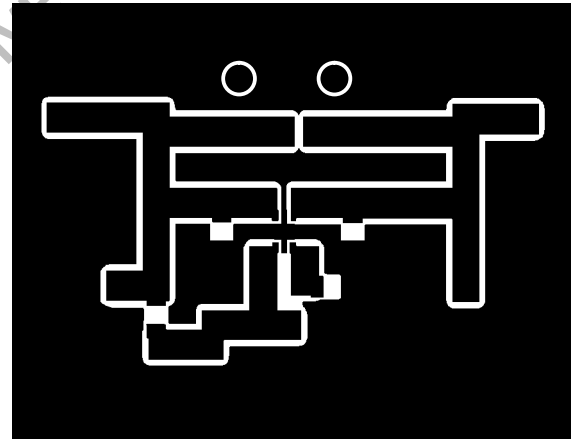

Figure 3. Printed Circuit Board

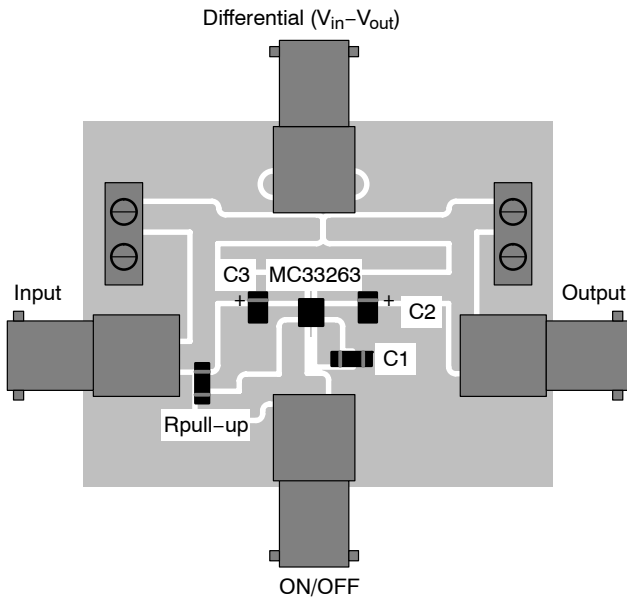

Figure 4. Copper Side Component Layout

This layout is the basis for an MC33263 performance evaluation board where the BNC connectors give the user an easy and quick evaluation mean.

MC33263 Wake-up Improvement - In portable applications, an immediate response to an enable signal is vital. If noise is not of concern, the MC33263 without a bypass capacitor settles in nearly 20 μ s and typically delivers 65 μ VRMS between 100 Hz and 100 kHz.

In ultra low-noise systems, the designer needs a 10 nF bypass capacitor to decrease the noise down to 25 μ VRMS between 100 Hz and 100 kHz. With the adjunction of the 10 nF capacitor, the wake-up time expands up to 1.0 ms as shown on the data-sheet curves. If an immediate response is wanted, following figure's circuit gives a solution to

charge the bypass capacitor with the enable signal without degrading the noise response of the MC33263.

At power-on, C4 is discharged. When the control logic sends its wake-up signal by going to a high level, the PNP base is momentarily tight to ground. The PNP switch closes and immediately charges the bypass capacitor C1 toward its operating value. After a few μ s, the PNP opens and becomes totally transparent to the regulator.

This circuit improves the response time of the regulator which drops from 1.0 ms down to 30 μ s. The value of C4 needs to be tweaked in order to avoid any bypass capacitor overload during the wake-up transient.

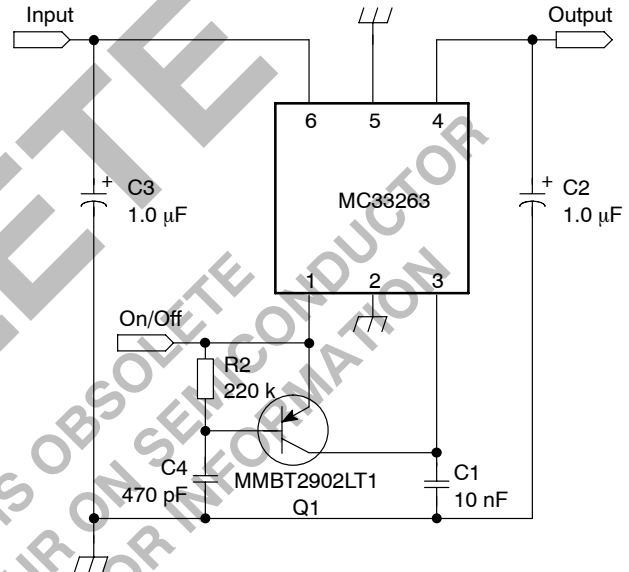

Figure 5. A PNP Transistor Drives the Bypass Pin when Enable Goes High (QFN6)

MC33263

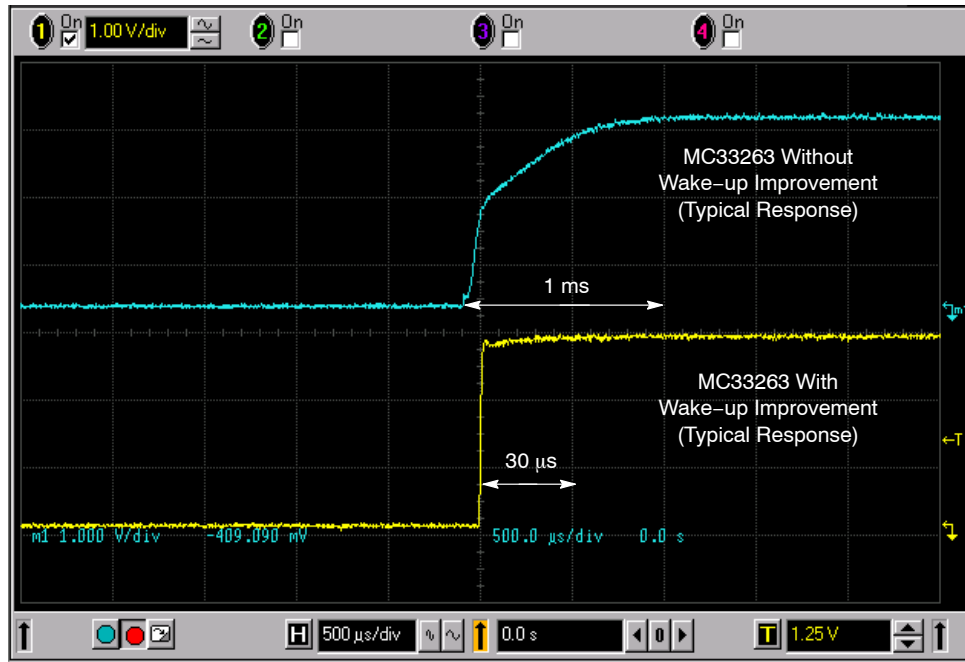

Figure 6. MC33263 Wake-up Improvement with Small PNP Transistor

The PNP being wired upon the bypass pin, it shall not degrade the noise response of the MC33263. Figure 7 confirms the good behavior of the integrated circuit in this

area which reaches a typical noise level of 26 μ V_{RMS} (100 Hz to 100 kHz) at $I_{out} = 60$ mA.

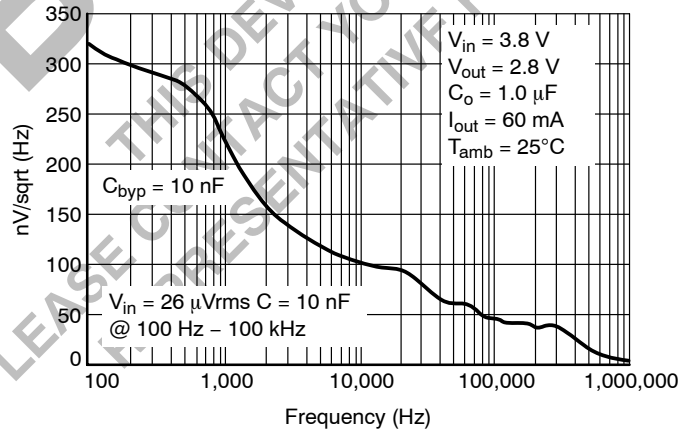

Figure 7. Noise Density of the MC33263 with a 10 nF Bypass Capacitor and a Wake-up Improvement Network

TYPICAL PERFORMANCE CHARACTERISTICS

Ground Current Performances

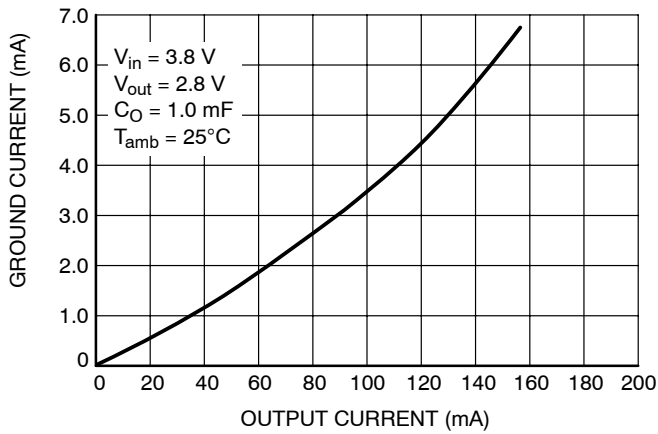

Figure 8. Ground Current versus Output Current

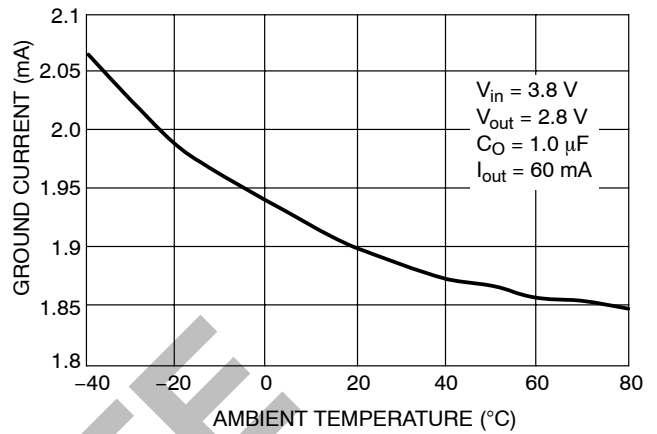

Figure 9. Ground Current versus Ambient Temperature

Line Transient Response and Output Voltage

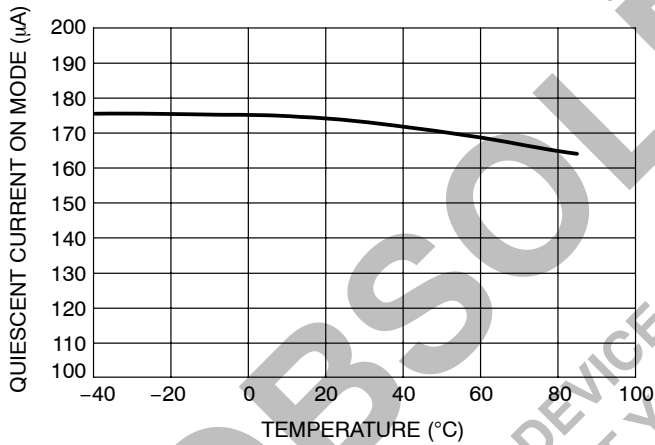

Figure 10. Quiescent Current versus Temperature

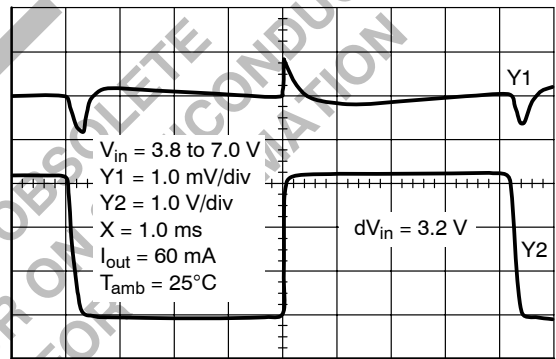
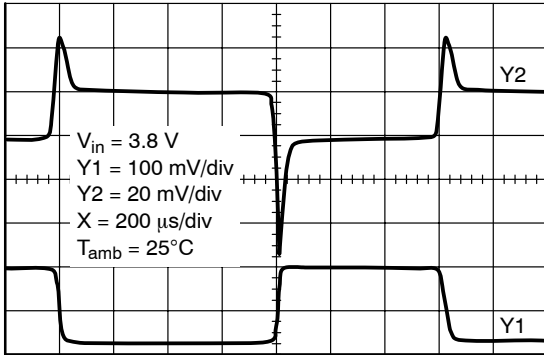

Figure 11. Line Transient Response

TYPICAL PERFORMANCE CHARACTERISTICS

Load Transient Response versus Load Current Slope



Y1: OUTPUT CURRENT, Y2: OUTPUT VOLTAGE

Figure 12. $I_{out} = 3.0 \text{ mA to } 150 \text{ mA}$

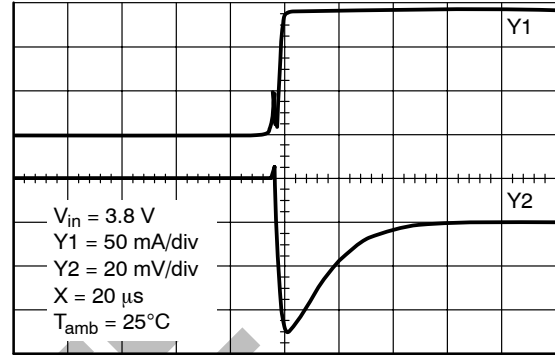

Y1: OUTPUT CURRENT, Y2: OUTPUT VOLTAGE

Figure 13. $I_{Slope} = 100 \text{ mA}/\mu\text{s}$ (Large Scale)
 $I_{out} = 3.0 \text{ mA to } 150 \text{ mA}$

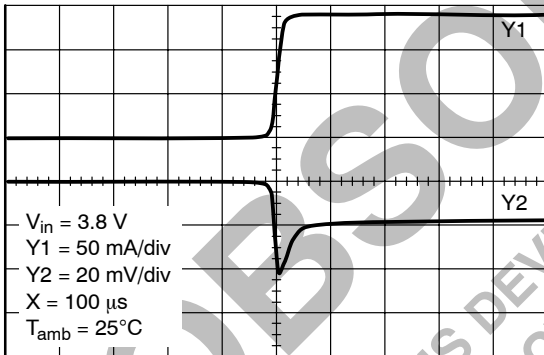

Y1: OUTPUT CURRENT, Y2: OUTPUT VOLTAGE

Figure 14. $I_{Slope} = 6.0 \text{ mA}/\mu\text{s}$ (Large Scale)
 $I_{out} = 3.0 \text{ mA to } 150 \text{ mA}$

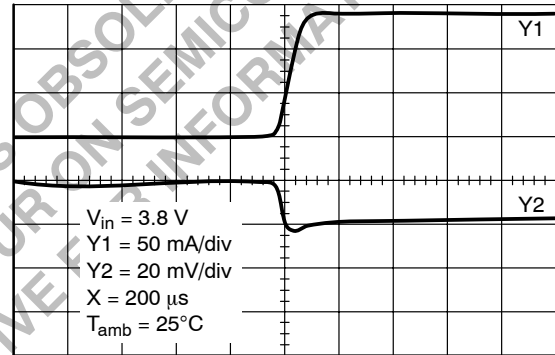

Y1: OUTPUT CURRENT, Y2: OUTPUT VOLTAGE

Figure 15. $I_{Slope} = 2.0 \text{ mA}/\mu\text{s}$ (Large Scale)
 $I_{out} = 3.0 \text{ mA to } 150 \text{ mA}$

TYPICAL PERFORMANCE CHARACTERISTICS

Noise Performances

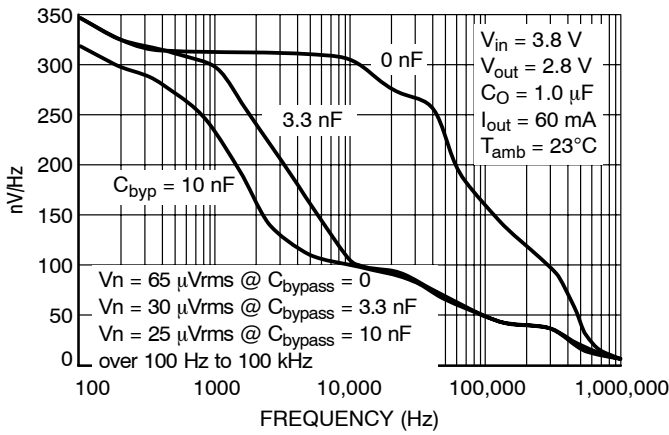

Figure 16. Noise Density versus Bypass Capacitor

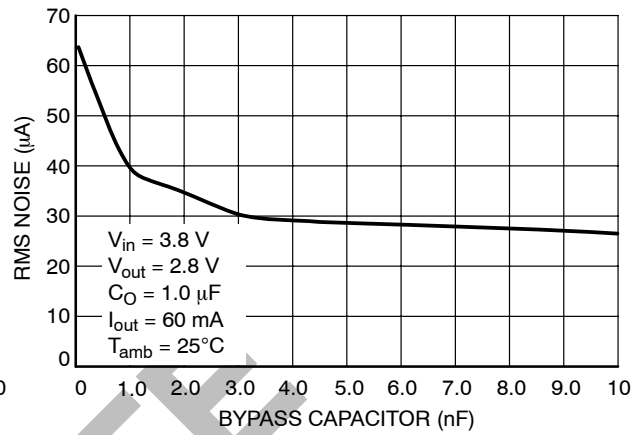

Figure 17. RMS Noise versus Bypass Capacitor (100 Hz - 100 kHz)

Settling Time Performances

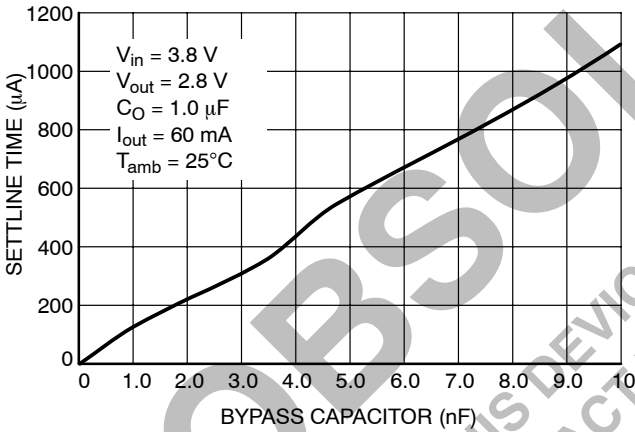

Figure 18. Output Voltage Settling Time versus Bypass Capacitor

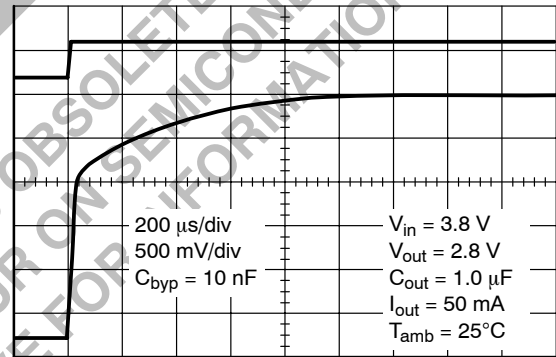

Figure 19. Output Voltage Settling Shape
Cbypass = 10 nF

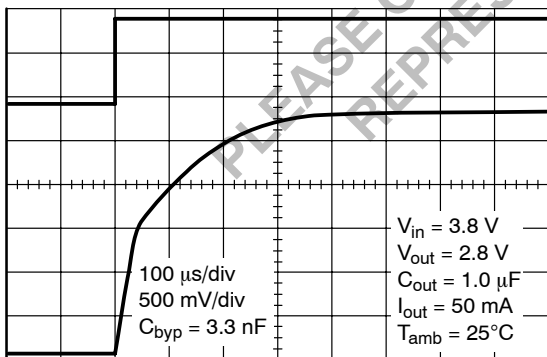

Figure 20. Output Voltage Settling Shape
Cbypass = 3.3 nF

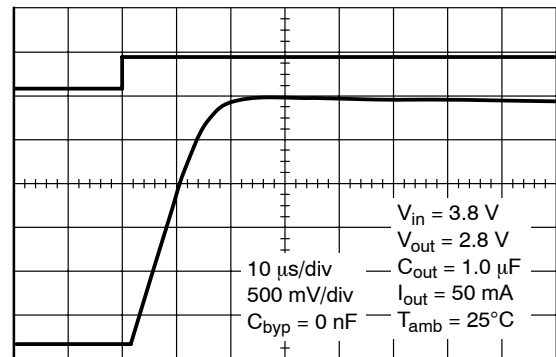

Figure 21. Output Voltage Settling Shape without Bypass Capacitor

TYPICAL PERFORMANCE CHARACTERISTICS

Dropout Voltage

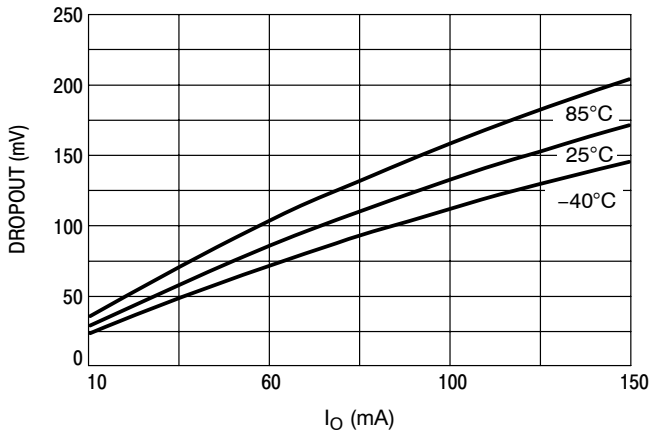

Figure 22. Dropout Voltage versus I_{out}

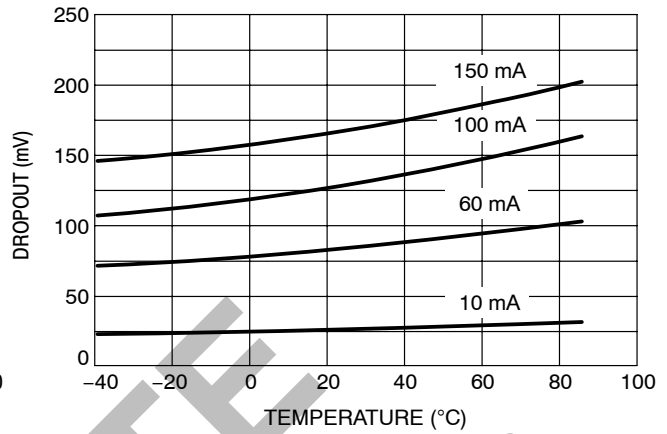

Figure 23. Dropout Voltage versus Temperature

Output Voltage

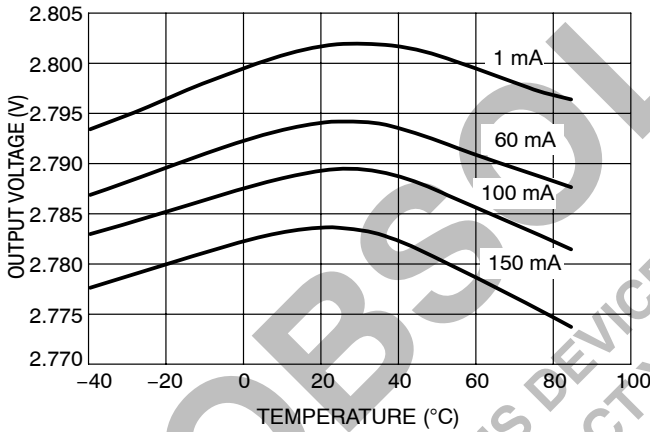

Figure 24. Output Voltage versus Temperature

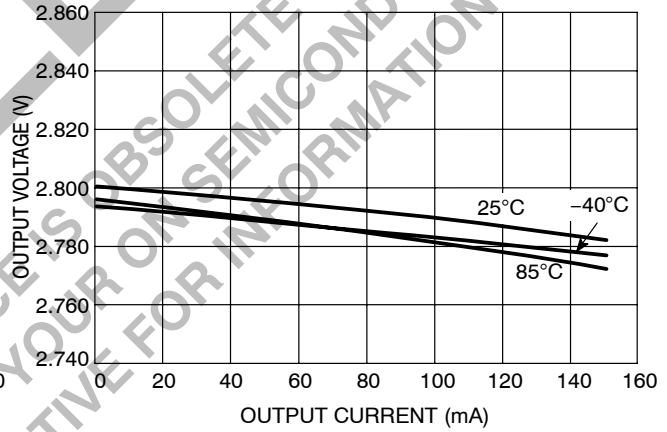

Figure 25. Output Voltage versus I_{out}

Ripple Rejection Performances

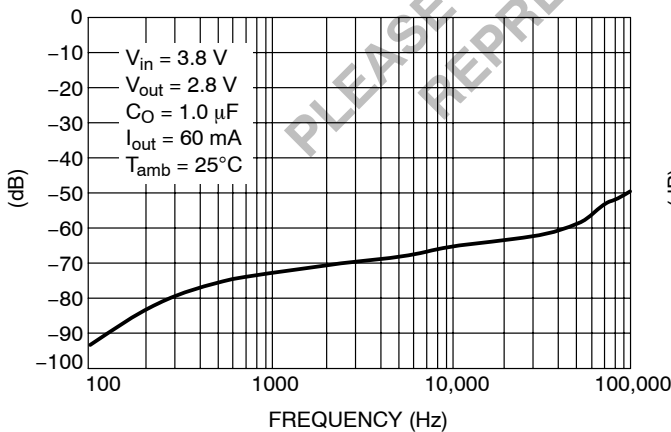

Figure 26. Ripple Rejection versus Frequency with 10 nF Bypass Capacitor

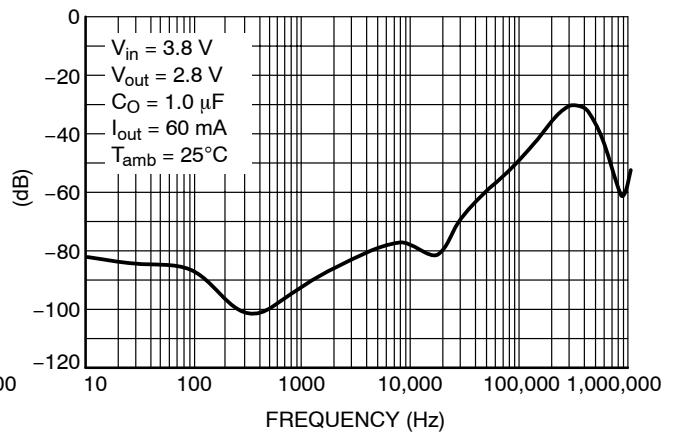

Figure 27. Ripple Rejection versus Frequency without Bypass Capacitor

MC33263

ORDERING INFORMATION

Device	Version	Package	Shipping†
MC33263DM-3.3R2	3.3 V	Micro8	4000 Tape & Reel
MC33263DM-5.0R2	5.0 V		
MC33263MN-3.3R2	3.3 V	QFN6, 3X3	3000 Tape & Reel
MC33263MN-5.0R2	5.0 V		

OBSOLETE
THIS DEVICE IS OBSOLETE
PLEASE CONTACT YOUR ON SEMICONDUCTOR
REPRESENTATIVE FOR INFORMATION

MC33263

PACKAGE DIMENSIONS

Micro8
DM SUFFIX
CASE 846A-02
ISSUE F

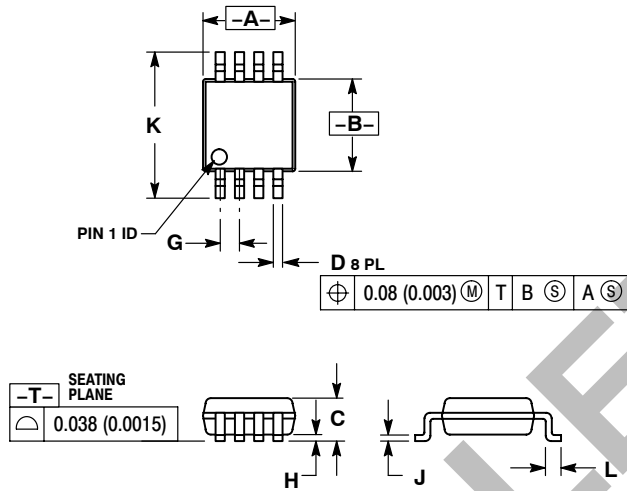

NOTES:

1. DIMENSIONING AND TOLERANCING PER ANSI Y14.5M, 1982.
2. CONTROLLING DIMENSION: MILLIMETER.
3. DIMENSION A DOES NOT INCLUDE MOLD FLASH, PROTRUSIONS OR GATE BURRS. MOLD FLASH, PROTRUSIONS OR GATE BURRS SHALL NOT EXCEED 0.15 (0.006) PER SIDE.
4. DIMENSION B DOES NOT INCLUDE INTERLEAD FLASH OR PROTRUSION. INTERLEAD FLASH OR PROTRUSION SHALL NOT EXCEED 0.25 (0.010) PER SIDE.
5. 846A-01 OBSOLETE, NEW STANDARD 846A-02.

QFN6, 3x3
MN SUFFIX
CASE TBD
ISSUE O

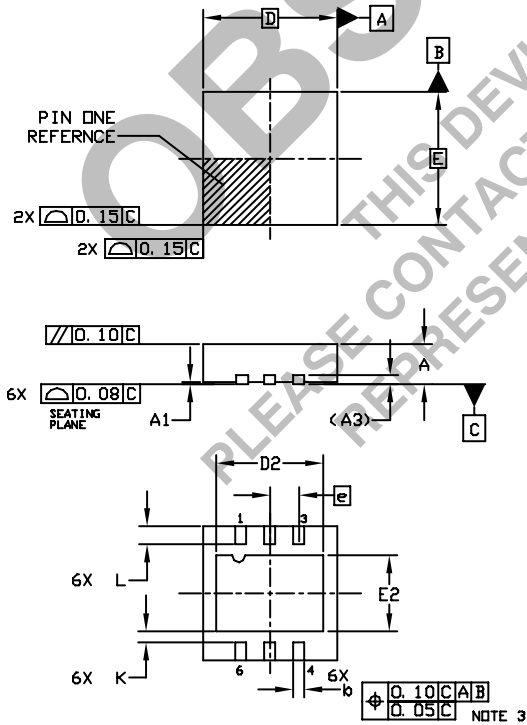

NOTES:

1. DIMENSIONING AND TOLERANCING PER ASME Y14.5M, 1994.
2. CONTROLLING DIMENSION: MILLIMETERS.
3. DIMENSION b APPLIES TO PLATED TERMINAL AND IS MEASURED BETWEEN 0.25 AND 0.30MM FROM TERMINAL.
4. COPLANARITY APPLIES TO THE EXPOSED PAD AS WELL AS THE TERMINALS.

OBSOLETE
 THIS DEVICE IS OBSOLETE
 PLEASE CONTACT YOUR ON SEMICONDUCTOR
 REPRESENTATIVE FOR INFORMATION

ON Semiconductor and  are registered trademarks of Semiconductor Components Industries, LLC (SCILLC). SCILLC reserves the right to make changes without further notice to any products herein. SCILLC makes no warranty, representation or guarantee regarding the suitability of its products for any particular purpose, nor does SCILLC assume any liability arising out of the application or use of any product or circuit, and specifically disclaims any and all liability, including without limitation special, consequential or incidental damages. "Typical" parameters which may be provided in SCILLC data sheets and/or specifications can and do vary in different applications and actual performance may vary over time. All operating parameters, including "Typicals" must be validated for each customer application by customer's technical experts. SCILLC does not convey any license under its patent rights nor the rights of others. SCILLC products are not designed, intended, or authorized for use as components in systems intended for surgical implant into the body, or other applications intended to support or sustain life, or for any other application in which the failure of the SCILLC product could create a situation where personal injury or death may occur. Should Buyer purchase or use SCILLC products for any such unintended or unauthorized application, Buyer shall indemnify and hold SCILLC and its officers, employees, subsidiaries, affiliates, and distributors harmless against all claims, costs, damages, and expenses, and reasonable attorney fees arising out of, directly or indirectly, any claim of personal injury or death associated with such unintended or unauthorized use, even if such claim alleges that SCILLC was negligent regarding the design or manufacture of the part. SCILLC is an Equal Opportunity/Affirmative Action Employer. This literature is subject to all applicable copyright laws and is not for resale in any manner.

PUBLICATION ORDERING INFORMATION

LITERATURE FULFILLMENT:

Literature Distribution Center for ON Semiconductor
 P.O. Box 5163, Denver, Colorado 80217 USA
Phone: 303-675-2175 or 800-344-3860 Toll Free USA/Canada
Fax: 303-675-2176 or 800-344-3867 Toll Free USA/Canada
Email: orderlit@onsemi.com

N. American Technical Support: 800-282-9855 Toll Free
 USA/Canada
Europe, Middle East and Africa Technical Support:
 Phone: 421 33 790 2910
Japan Customer Focus Center
 Phone: 81-3-5773-3850

ON Semiconductor Website: www.onsemi.com

Order Literature: <http://www.onsemi.com/orderlit>

For additional information, please contact your local
 Sales Representative