

# NCP3231N

## High Current Synchronous Buck Converter

The NCP3231N is a high current, high efficiency, voltage-mode synchronous buck converter which operates from 4.5 V to 18 V input and generates output voltages down to 0.6 V at up to 25 A.

### Features

- Wide Input Voltage Range from 4.5 V to 18 V
- 0.6 V Internal Reference Voltage
- 500 kHz Switching Frequency
- External Programmable Soft-start
- Lossless Low-side FET Current Sensing
- Output Over-voltage Protection and Under-voltage Protection
- System Over-temperature Protection using a Thermistor or Sensor
- Hiccup Mode Operation for All Faults
- Pre-bias Start-up
- Adjustable Output Voltage
- Power Good Output
- Internal Over-temperature Protection
- This is a Pb-Free Device\*

### Typical Applications

- Cellular Base Stations
- ASIC, FPGA, DSP and CPU Core and I/O Supplies
- Telecom and Network Equipment
- Server and Storage System

\*For additional information on our Pb-Free strategy and soldering details, please download the ON Semiconductor Soldering and Mounting Techniques Reference Manual, SOLDERRM/D.



**ON Semiconductor®**

[www.onsemi.com](http://www.onsemi.com)

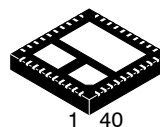

**QFN40 6x6, 0.5P  
CASE 485FJ**

### MARKING DIAGRAM

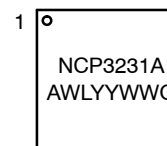

NCP3231A = Specific Device Code  
 A = Assembly Location  
 WL = Wafer Lot  
 YY = Year  
 WW = Work Week  
 G = Pb-Free Package

### PIN CONNECTIONS

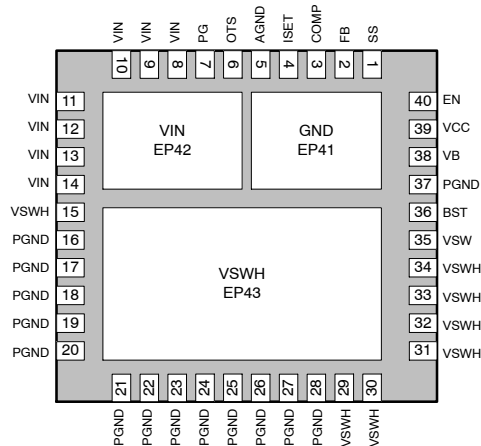

(TOP VIEW)

### ORDERING INFORMATION

Device	Package	Shipping†
NCP3231NMNTXG	QFN40 (Pb-Free)	2500 / Tape & Reel

†For information on tape and reel specifications, including part orientation and tape sizes, please refer to our Tape and Reel Packaging Specification Brochure, BRD8011/D.

# NCP3231N

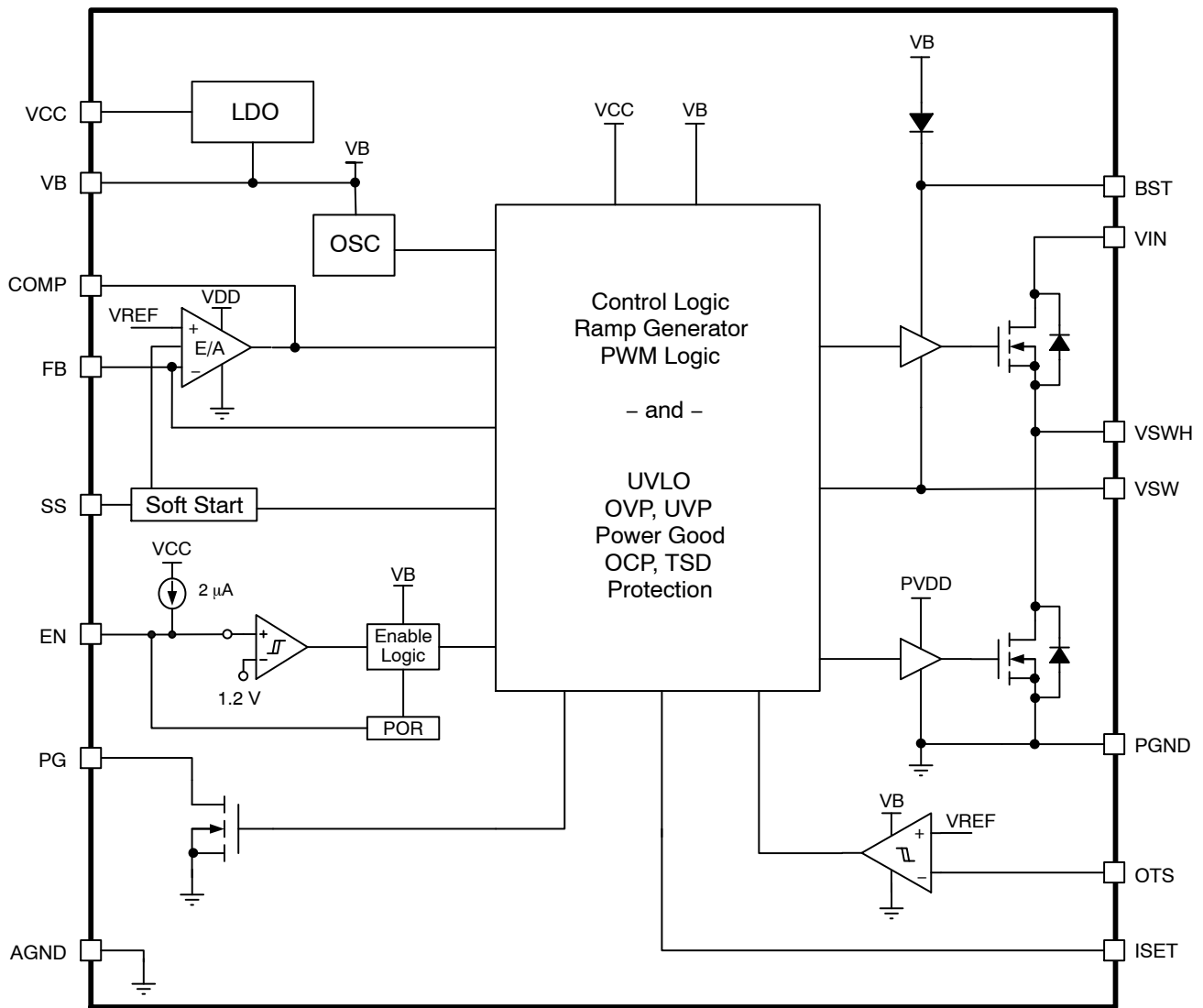

Figure 1. NCP3231N Block Diagram

# NCP3231N

## PIN DESCRIPTION

Pin No.	Symbol	Description
1	SS	A capacitor from this pin to GND allows the user to adjust the soft-start ramp time.
2	FB	Output voltage feedback.
3	COMP	Output of the error amplifier.
4	ISET	A resistor from this pin to ground sets the over-current protection (OCP) threshold.
5	AGND	Analog ground.
6	OTS	Negative input of internal thermal comparator. Tie this pin to ground if not in use.
7	PG	Power good indicator of the output voltage. Open-drain output. Connect PG to VDD with an external resistor.
8-14, EP42	VIN	The VIN pin is connected to the internal power NMOS switch. The VIN pin has high di/dt edges and must be decoupled to ground close to the pin of the device.
15, 29-34, EP43	VSWH	The VSWH pin is the connection of the drain and source of the internal NMOS switches. At switch off, the inductor will drive this pin below ground as the body diode and the NMOS conducts with a high dv/dt.
16-28, 37	PGND	Ground reference and high-current return path for the bottom gate driver and low-side NMOS.
35	VSW	IC connection to the switch node between the top MOSFET and bottom MOSFET. Return path of the high-side gate driver.
36	BST	Top gate driver input supply, a bootstrap capacitor connection between the switch node and this pin.
38	VB	The internal LDO output and input supply for the NCP3231N. Connect a minimum of 4.7 $\mu$ F ceramic capacitor from this pin to ground.
39	VCC	Input Supply for IC. This pin must be connected to VIN.
40	EN	Logic control for enabling the switcher. An internal pull-up enables the device automatically. The EN pin can also be driven high to turn on the device, or low to turn off the device. A comparator and precision reference allow the user to implement this pin as an adjustable UVLO circuit.
EP41	GND	Exposed Pad. Connect GND to a large copper plane at ground potential to improve thermal dissipation.

# NCP3231N

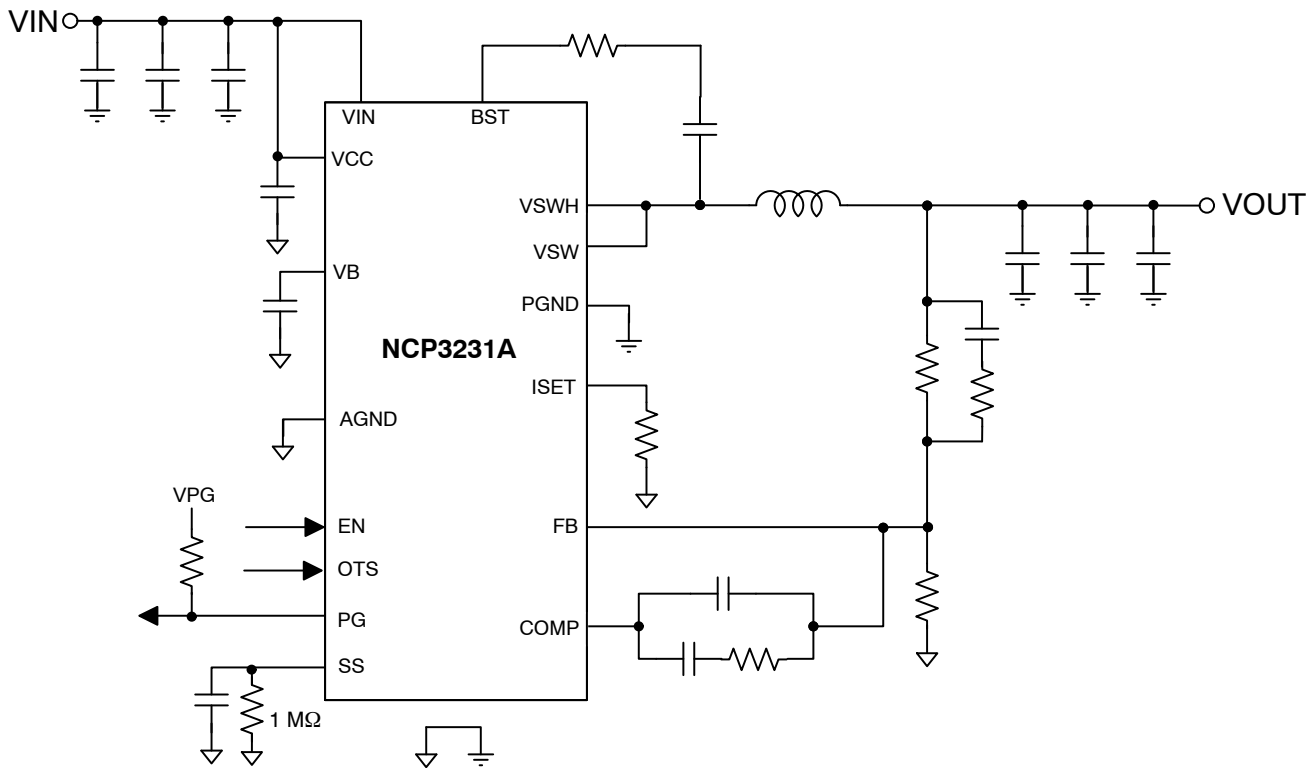

Figure 2. Typical Application Circuit

## ABSOLUTE MAXIMUM RATINGS (measured vs. GND pad, unless otherwise noted)

Rating	Symbol	Value	Unit
Power Supply to GND	VIN, VCC	20.5 -0.3	V
VSW to GND	VSWH, VSW	26 -0.6 (DC) +35 (t < 50 ns) -5 (t < 100 ns)	V
BST to GND	BST	30 (DC) -0.6 (DC) +40 (t < 50 ns)	V
All other pins		6.0 -0.3	V
Operating Ambient Temperature Range (Note 1)	T <sub>A</sub>	-40 to +90	°C
Operating Junction Temperature Range (Note 1)	T <sub>J</sub>	-40 to +150	°C
Maximum Junction Temperature	T <sub>J(MAX)</sub>	+150	°C
Storage Temperature Range	T <sub>stg</sub>	-55 to +150	°C

## THERMAL INFORMATION

HS FET Junction-to-Case Thermal Resistance (Note 2)	R <sub>θJC-HS</sub>	1.3	°C/W
LS FET Junction-to-Case Thermal Resistance (Note 2)	R <sub>θJC-LS</sub>	0.6	°C/W

Stresses exceeding those listed in the Maximum Ratings table may damage the device. If any of these limits are exceeded, device functionality should not be assumed, damage may occur and reliability may be affected.

1. The maximum package power dissipation limit must not be exceeded.

$$P_D = \frac{T_{J(MAX)} - T_A}{R_{\theta JA}}$$

2. R<sub>θJC</sub> thermal resistance is obtained by simulating a cold plate test on the exposed power pad. No specific JEDEC standard test exists, but a close description can be found in the ANSI SEMI standard G30-88.

# NCP3231N

## ELECTRICAL CHARACTERISTICS

( $-40^{\circ}\text{C} < T_J < +125^{\circ}\text{C}$ ,  $V_{CC} = 12\text{ V}$ , for min/max values unless otherwise noted,  $T_J = +25^{\circ}\text{C}$  for typical values)

Parameter	Symbol	Test Conditions	Min	Typ	Max	Units
-----------	--------	-----------------	-----	-----	-----	-------

### POWER SUPPLY

VIN/VCC Operation Voltage	VIN/VCC		4.5		18	V
VB UVLO Threshold (Rising)			4.1	4.2	4.3	V
VB UVLO Threshold (Falling)			3.4	3.66	3.8	V
VB Output Voltage	VB	$V_{CC} = 6\text{ V}$ , $0 \leq I_B \leq 40\text{ mA}$	4.9	5.15	5.45	V
VB Dropout Voltage		$I_B = 25\text{ mA}$ , $V_{CC} = 4.5\text{ V}$		36	110	mV
VCC Quiescent Current		EN = H, COMP = H, no switching; PG open; no switching		4.7	6.4	mA
Shutdown Supply Current		NCP3231N; EN = 0; $V_{CC} = 18\text{ V}$ ; PG open		100	140	$\mu\text{A}$
		NCP3231N; EN = 0; $V_{CC} = 4.5\text{ V}$ ; PG open		53	75	$\mu\text{A}$

### FEEDBACK VOLTAGE

FB Input Voltage	VFB	$T_J = 25^{\circ}\text{C}$ , $4.5\text{ V} \leq V_{CC} \leq 18\text{ V}$	597	600	603	mV
		$-40^{\circ}\text{C} \leq T_J \leq 125^{\circ}\text{C}$ ; $4.5\text{ V} \leq V_{CC} \leq 18\text{ V}$	594	600	606	
Feedback Input Bias Current	IFB	VFB = 0.6 V			75	nA

### ERROR AMPLIFIER

Open Loop DC Gain		Guaranteed by Design	60	85		dB
Open Loop Unity Gain Bandwidth	F0dB,EA			24		MHz
Open Loop Phase Margin				60		$^{\circ}$
Slew Rate		COMP pin to GND = 10 pF		2.5		V/ $\mu$
COMP Clamp Voltage, High				3.46		V
COMP Clamp Voltage, Low				465		mV
Output Source Current		VFB = 0 V	15			mA
Output Sink Current		VFB = 1 V	20			mA

### CURRENT LIMIT

Low-side ISET Current Source	LS_ISET	Sourced from ISET pin, before SS, $T_J = 25^{\circ}\text{C}$		34		$\mu\text{A}$
Low-side ISET Current Source Temperature Coefficient	TC_LS_ISET			+0.31		%/ $^{\circ}\text{C}$
Low-side OCP Switch-over Threshold		Guaranteed by Design		600		mV
Low-side Fixed OCP Threshold	LS_OCPth	Guaranteed by Design		300		mV
Low-side Programmable OCP Range	LS_OCPth				< 600	mV
LS OCP Blanking time	LS_Tblnk	Guaranteed by Design		150		ns

### PWM

Maximum duty cycle		fsw = 500 kHz, VFB = 0 V $4.5\text{ V} < V_{CC} < 18\text{ V}$		92		%
Minimum duty cycle		VCOMP < PWM Ramp Offset Voltage		0		%
Minimum GH on-time		Guaranteed by Characterization		60		ns
PWM Ramp Amplitude		Guaranteed by Characterization	VCC/8.6	VCC/6.6	VCC/5.6	V
PWM Ramp Offset		Guaranteed by Characterization		0.64		V

### OSCILLATOR

Oscillator Frequency Range	fsw	fsw = 500 kHz $4.5\text{ V} < V_{CC} < 18\text{ V}$	450	500	550	kHz
----------------------------	-----	--	-----	-----	-----	-----

# NCP3231N

## ELECTRICAL CHARACTERISTICS

( $-40^{\circ}\text{C} < T_J < +125^{\circ}\text{C}$ ,  $V_{CC} = 12\text{ V}$ , for min/max values unless otherwise noted,  $T_J = +25^{\circ}\text{C}$  for typical values)

Parameter	Symbol	Test Conditions	Min	Typ	Max	Units
-----------	--------	-----------------	-----	-----	-----	-------

### OSCILLATOR

Hiccup Timer	$t_{\text{hiccup}}$	$t_{\text{ss}} < 1\text{ ms}$ , $f_{\text{sw}} = 500\text{ kHz}$		4		ms
		$t_{\text{ss}} > 1\text{ ms}$ , $f_{\text{sw}} = 500\text{ kHz}$		4 x tss		ms

### ENABLE INPUT (EN)

EN Input Operating Range					5.5	V
Enable Threshold Voltage	$V_{\text{EN}}$	VEN rising	1.11	1.2	1.29	V
Enable Hysteresis		VEN falling		144		mV
Deep Disable Threshold			0.7	0.78	0.9	V
Enable Pull-up Current				2		$\mu\text{A}$

### SOFTSTART INPUT (SS)

SS Startup Delay	$t_{\text{SSD}}$			1.33		ms
SS End Threshold	SSEND			0.6		V
SS Source Current	ISS		2.15	2.5	2.8	$\mu\text{A}$

### VOLTAGE MONITOR

Power Good Sink Current		PG = 0.15 V	10	20	30	mA
Output Overvoltage Rising Threshold			665	675	685	mV
Overvoltage Fault Blanking Time				20		$\mu\text{s}$
Output Under-Voltage Trip Threshold			500	525	550	mV
Under-voltage Protection Blanking Time				20		$\mu\text{s}$
OVP and UVP Enable Delay				$t_{\text{ss}}$		s

### POWER STAGE

High-side On Resistance	RDSONH	$V_{\text{IN}}/V_{\text{CC}} = 5\text{ V}$ , $I_{\text{D}} = 2\text{ A}$		7	9.9	$\text{m}\Omega$
Low-side On Resistance	RDSONL	$V_{\text{IN}}/V_{\text{CC}} = V_{\text{B}}$ , $I_{\text{D}} = 2\text{ A}$		1.5	2.9	$\text{m}\Omega$
VFBOOT		IBOOT = 2 mA		0.28		V

### THERMAL MONITOR (OTS)

OTS comparator reference voltage (Rising Threshold)			0.59	0.6	0.61	V
OTS comparator reference voltage (Falling Hysteresis)				50		mV

### THERMAL SHUTDOWN

Thermal Shutdown Threshold		Guaranteed by design	135	150	165	$^{\circ}\text{C}$
Thermal Shutdown Hysteresis		Guaranteed by design		25		$^{\circ}\text{C}$

Product parametric performance is indicated in the Electrical Characteristics for the listed test conditions, unless otherwise noted. Product performance may not be indicated by the Electrical Characteristics if operated under different conditions.

# NCP3231N

## TYPICAL CHARACTERISTICS

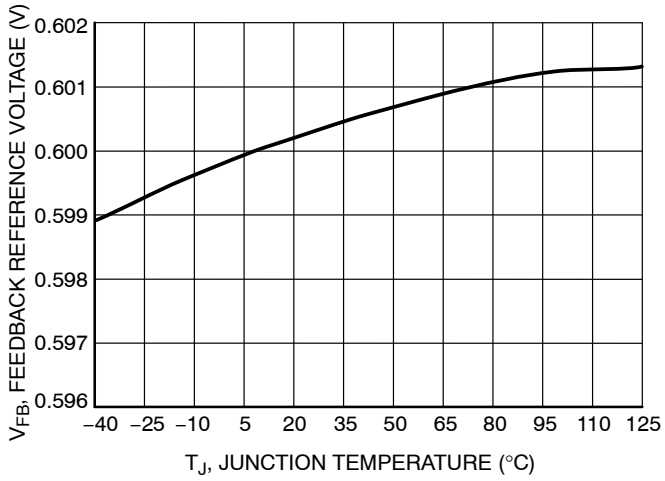

Figure 3. Reference Voltage vs. Temperature

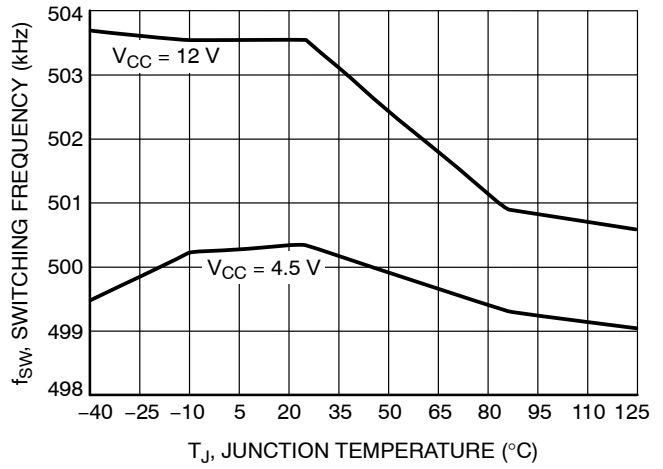

Figure 4. Switching Frequency vs. Temperature

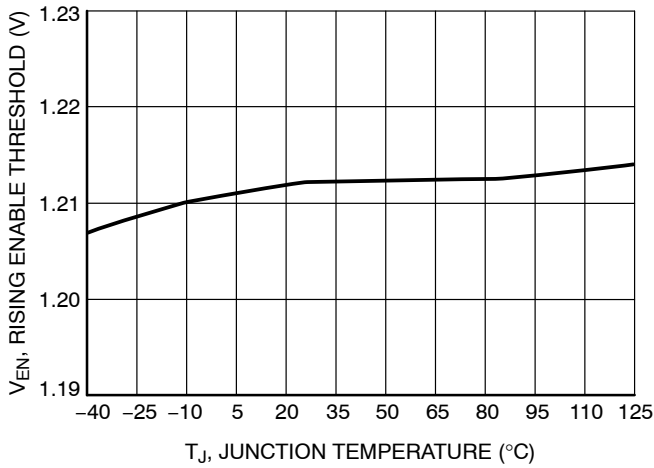

Figure 5. Rising Enable Threshold vs. Temperature

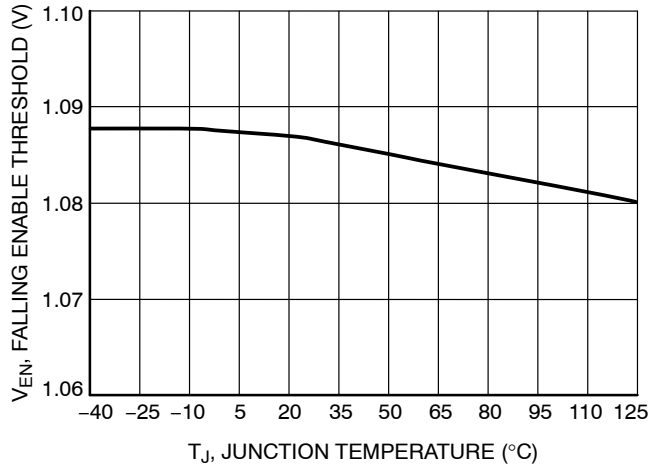

Figure 6. Falling Enable Threshold vs. Temperature

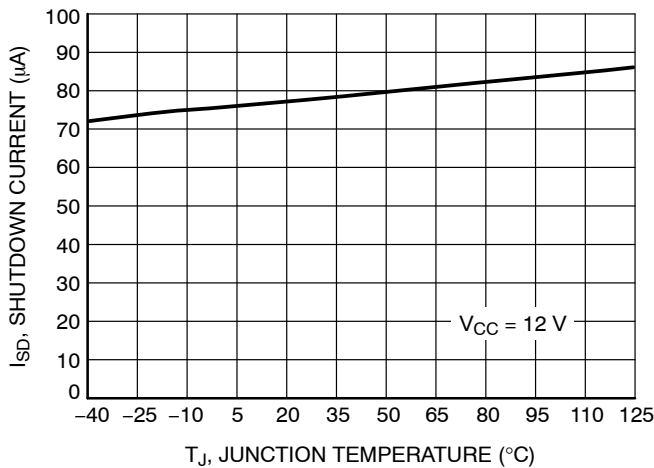

Figure 7. Shutdown Current vs. Temperature

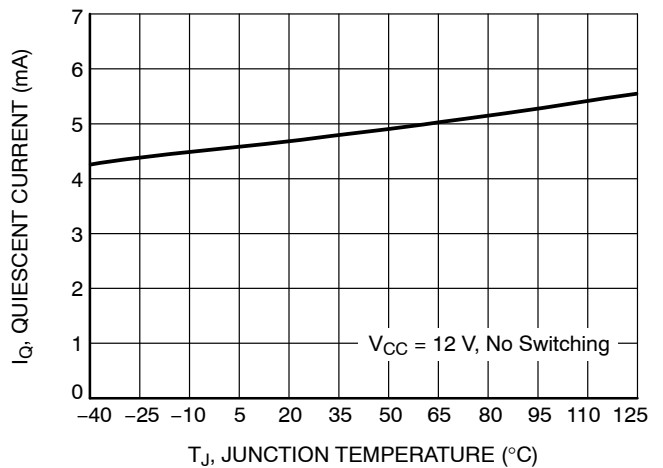

Figure 8. Quiescent Current vs. Temperature

TYPICAL CHARACTERISTICS

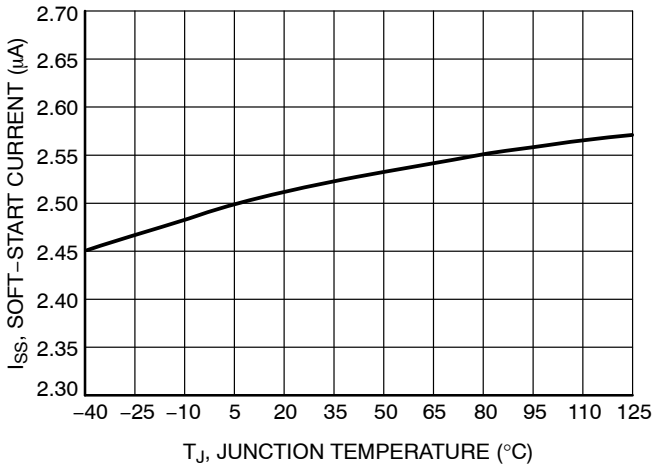

Figure 9. Soft-start Current vs. Temperature

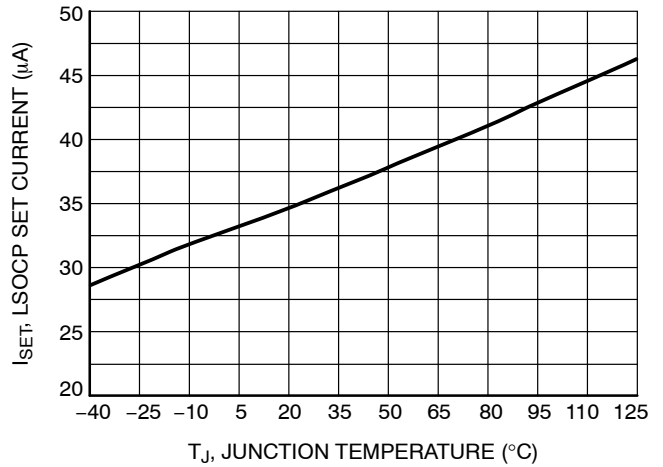

Figure 10. ISET Current vs. Temperature

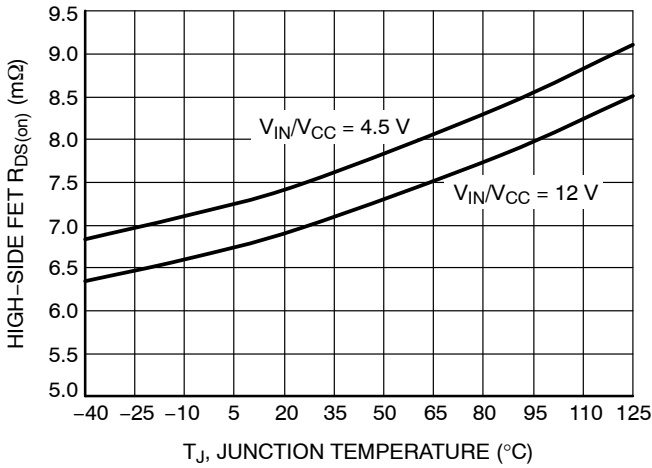

Figure 11. High-side  $R_{DS(on)}$  vs. Temperature

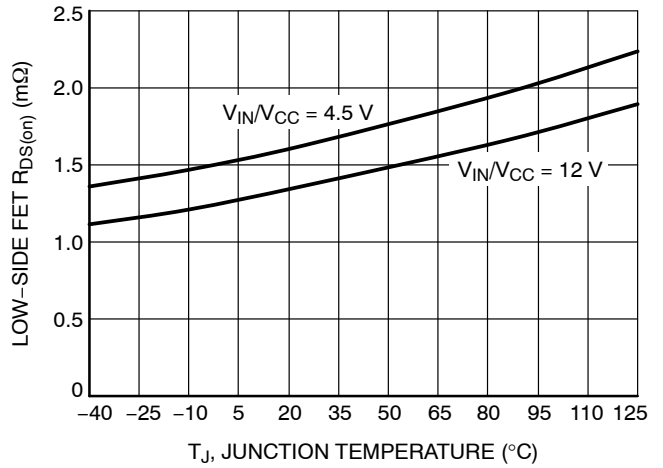

Figure 12. Low-side  $R_{DS(on)}$  vs. Temperature

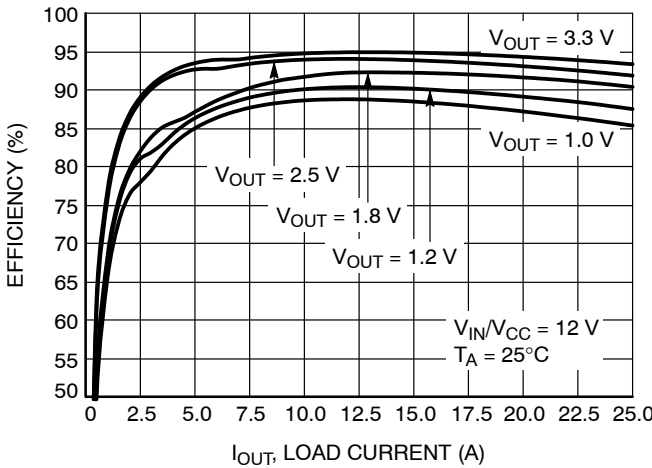

Figure 13. Efficiency vs.  $I_{out}$   
( $V_{in} = 12 V$ )

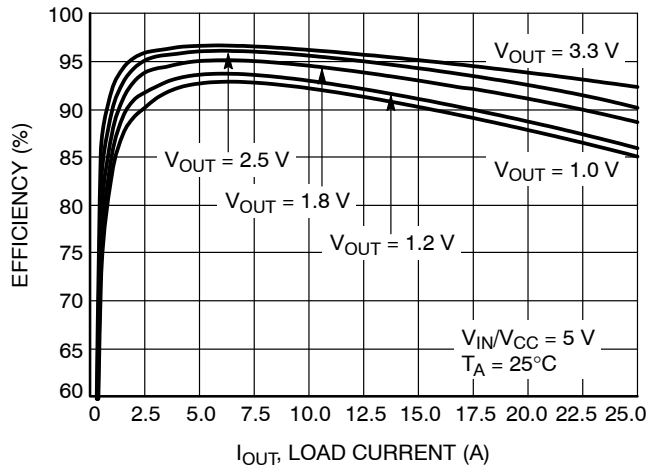

Figure 14. Efficiency vs.  $I_{out}$   
( $V_{in} = 5 V$ )



# NCP3231N

## TYPICAL CHARACTERISTICS

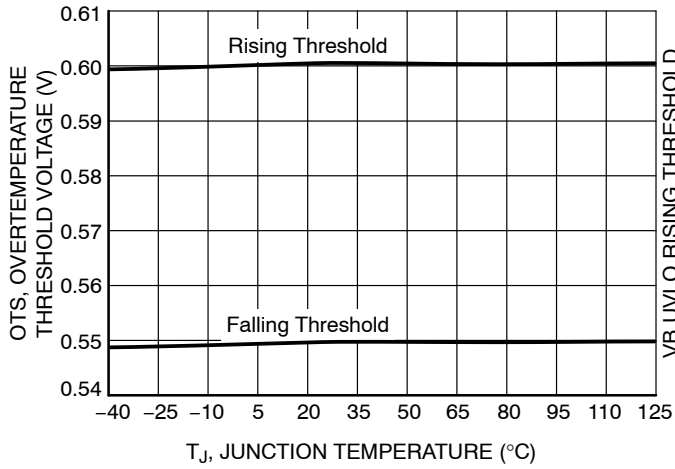

Figure 15. OTS Threshold vs. Temperature

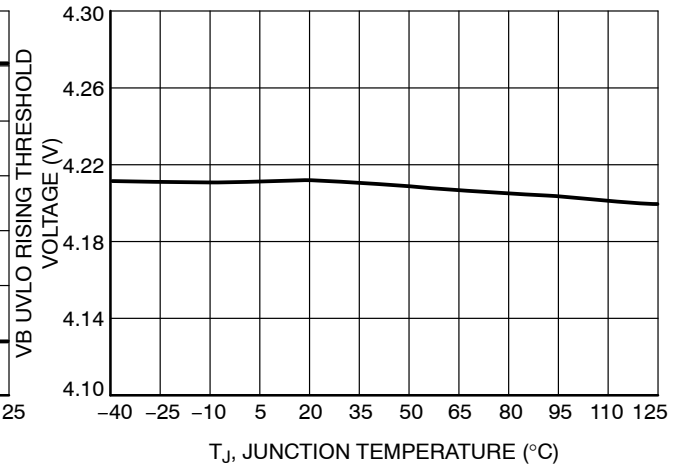

Figure 16. VB UVLO Rising Threshold vs. Junction Temperature

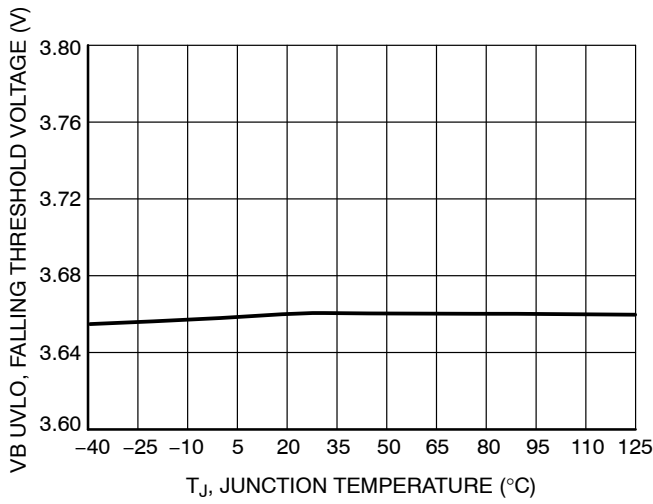

Figure 17. VB UVLO Falling Threshold vs. Junction Temperature

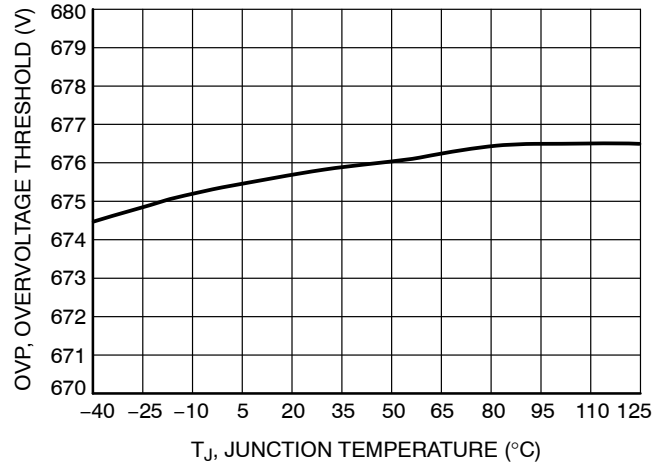

Figure 18. Output OVP vs. Junction Temperature

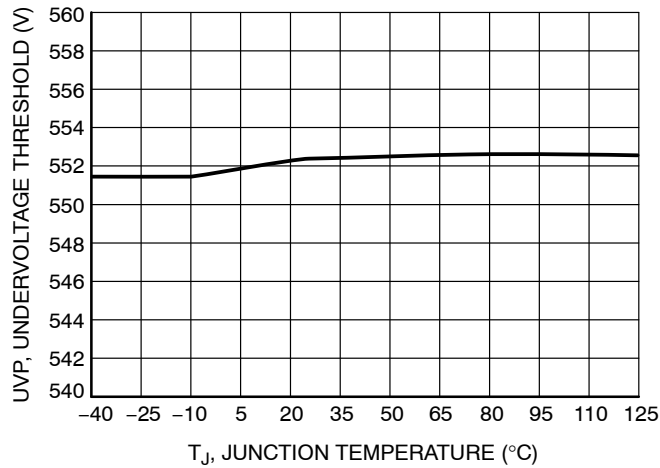
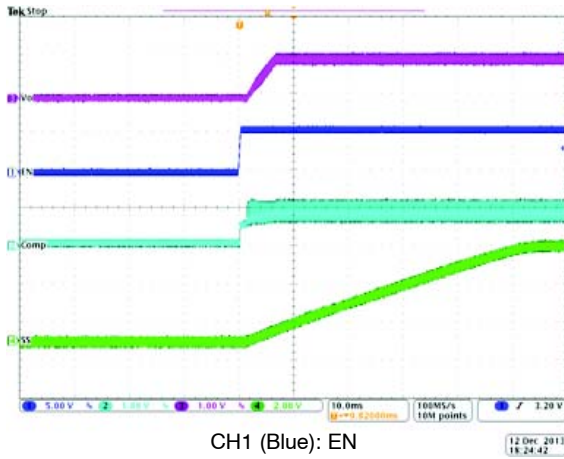

Figure 19. Output UVP vs. Junction Temperature

# NCP3231N

## TYPICAL CHARACTERISTICS



CH1 (Blue): EN  
CH2 (Aqua): COMP  
CH3 (Purple): Vout  
CH4 (Green): SS

12 Dec 2013  
18:24:42

**Figure 20. Typical Startup Waveforms**  
( $V_{in} = 12\text{ V}$ ,  $I_{out} = 25\text{ V}$ ,  $V_{out} = 1\text{ V}$ )

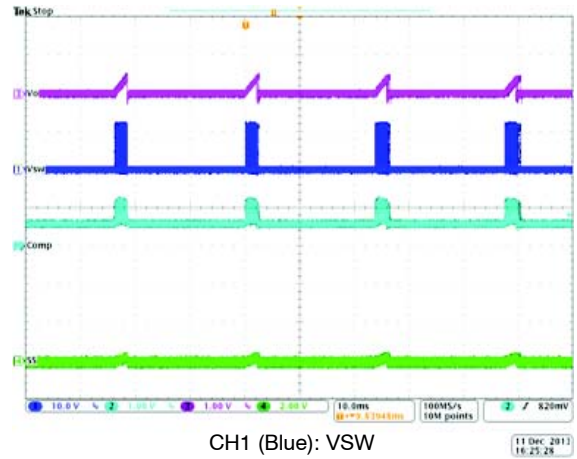

CH1 (Blue): VSW  
CH2 (Aqua): COMP  
CH3 (Purple): Vout  
CH4 (Green): SS

11 Dec 2013  
16:25:28

**Figure 21. Typical Short Circuit Waveforms**  
( $V_{in} = 12\text{ V}$ )

OPERATION DESCRIPTION

**Overview**

The NCP3231N is a 500 kHz, high efficiency, high current PWM synchronous buck converter. It operates with a single supply voltage from 4.5 to 18 V and can provide output current as high as 25 A. NCP3231N utilizes voltage mode with voltage feed-forward control to respond instantly to Vin changes and provide for easier compensation over the supply range of the converter. The device also includes pre-bias startup capability to allow monotonic startup in the event of a pre-biased output condition.

Protection features include overcurrent protection (OCP), output over and under voltage protection (OVP, UVP), and power good. The enable function is highly programmable to allow for adjustable startup voltages at higher input voltages. There is also an adjustable soft-start, an over-temperature/over-voltage comparator, and internal thermal shutdown.

**Reference Voltage**

The NCP3231N incorporates an internal reference that allows output voltages as low as 0.6 V. The tolerance of the internal reference is guaranteed over the entire operating temperature range of the controller. The reference voltage is trimmed using a test configuration that accounts for error amplifier offset and bias currents.

**Oscillator Ramp**

The ramp waveform is a saw tooth formed at the PWM frequency with a peak-to-peak amplitude of VCC/6.6, offset from GND by typically 0.64 V. The PWM duty cycle is limited to a maximum of 92%, allowing the bootstrap capacitor to charge during each cycle.

**Error Amplifier**

The error amplifier’s primary function is to regulate the converter’s output voltage using a resistor divider connected from the converter’s output to the FB pin of the controller, as shown in the Applications Schematic. A type III compensation network must be connected around the error amplifier to stabilize the converter. It has a bandwidth of greater than 24 MHz, with open loop gain of at least 60 dB.

**Programmable Soft-Start**

An external capacitor connected from the SS pin to ground sets up the soft start period, which can limit the start-up inrush current. The soft start period can be programmed based on the Equation 1.

$$t_{SS} = \frac{C_{SS} \times V_{ref}}{I_{SS}} \quad (eq. 1)$$

OCP is the only fault that is active during a soft-start.

**Adaptive Non-Overlap Gate Driver**

In a synchronous buck converter, a certain dead time is required between the low side drive signal and high side

drive signal to avoid shoot through. During the dead time, the body diode of the low side FET freewheels the current. The body diode has much higher voltage drop than that of the MOSFET, which reduces the efficiency significantly. The longer the body diode conducts, the lower the efficiency. NCP3231N implements adaptive dead time control to minimize the dead time, as well as preventing shoot through.

**Precision Enable (EN)**

The ENABLE block allows the output to be toggled on and off and is a precision analog input.

When the EN voltage exceeds V\_EN, the controller will initiate the soft-start sequence as long as the input voltage and sub-regulated voltage have exceeded their UVLO thresholds. V\_EN\_hyst helps to reject noise and allow the pin to be resistively coupled to the input voltage or sequenced with other rails.

If the EN voltage is held below typically 0.8 V, the NCP3231N enters a deep disable state where the internal bias circuitry is off. As the voltage at EN continues to rise, the Enable comparator and reference are active and provide a more accurate EN threshold. The drivers are held off until the rising voltage at EN crosses V\_EN.

An internal 2 μA pullup automatically enables the device when the EN pin is left floating.

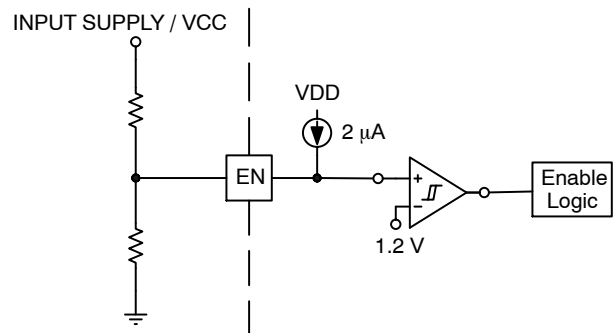

Figure 22. Enable Functional Block Diagram

**Pre-bias Startup**

In some applications the controller will be required to start switching when its output capacitors are charged anywhere from slightly above 0 V to just below the regulation voltage. This situation occurs for a number of reasons: the converter’s output capacitors may have residual charge on them or the converter’s output may be held up by a low current standby power supply. NCP3231N supports pre-bias start up by holding off switching until the feedback voltage and thus the output voltage rises above the set regulated voltage. If the pre-bias voltage is higher than the set regulated voltage, switching does not occur until the output voltage drops back to the regulation point.

# NCP3231N

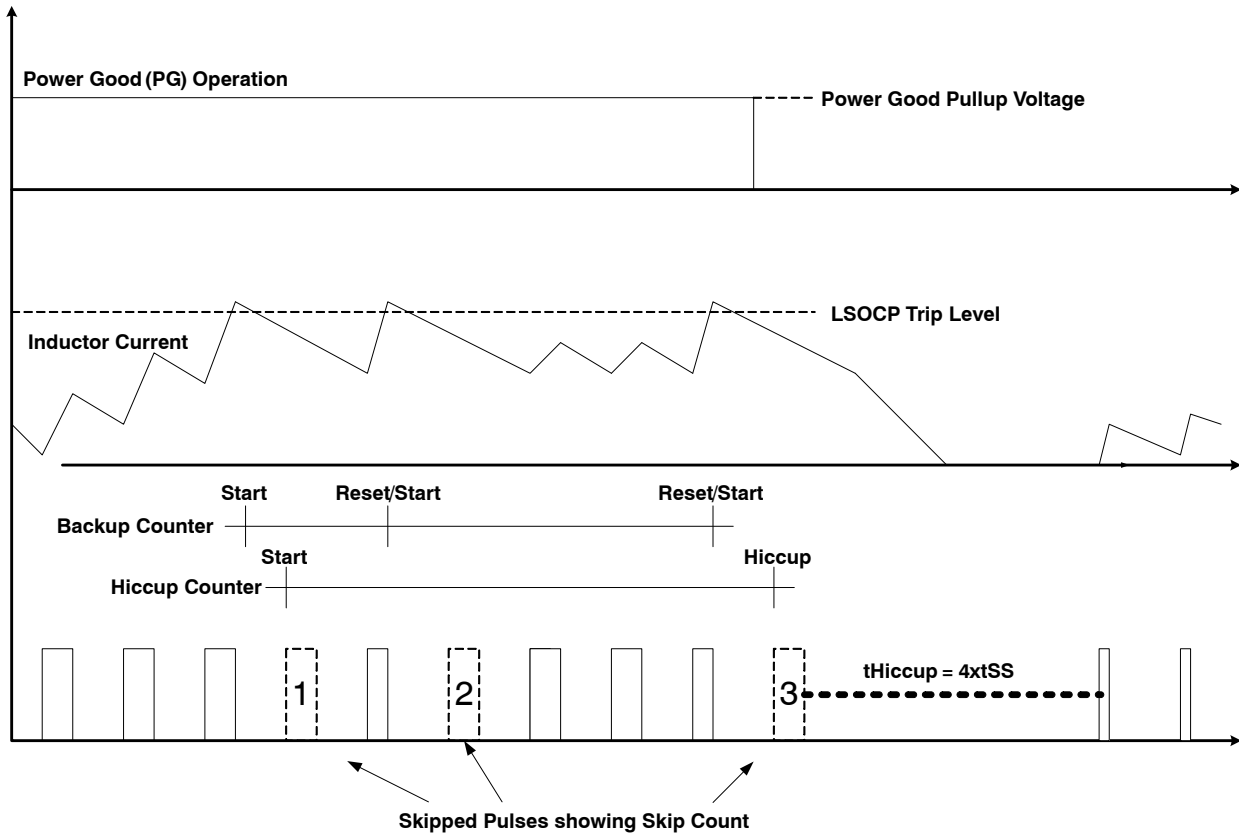

Figure 23. LSOCP Function with Counters and Power Good Shown (exaggerated for informational purposes)

## PROTECTION FEATURES

### Hiccup Mode

The NCP3231N utilizes hiccup mode for all of its fault conditions. Upon entering hiccup mode after a fault detection, the NCP3231N turns off the high side and low side FET's and PG goes low. It waits for  $t_{HICCUP}$  ms before reinitiating a soft-start.  $t_{HICCUP}$  is defined as four soft start timeouts (tss). And if the soft-start time tss is set to be less than 1 ms, the hiccup time will be 4 ms. The equation for tss is shown in Equation 1. OCP is the only active fault detection during the hiccup mode soft start.

### Over Temperature Comparator (OTS)

The NCP3231N provides an over-temperature shutdown (OTS) comparator with 50 mV hysteresis and a 0.6 V reference in order to remotely sense an external temperature detector or thermistor. When the voltage at the OTS pin rises above 0.6 V, the drivers stop switching and both FET's remain off. When this voltage drops below typically 0.55 V, a new soft-start cycle is generated automatically. Tie the OTS pin to ground if this function is not required.

### Over Voltage Protection (OVP)

When the voltage at the FB pin (VFB) is above the OVP threshold for greater than 20  $\mu$ s (typical), an OVP fault is set. The high side FET (HSFET) will turn off and the low side FET (LSFET) will turn on. The open-drain PG pull down

will turn on at that point as well, thus pulling PG low. Once VFB has fallen below the Undervoltage Protection Threshold (UVP), the device will enter hiccup mode.

### Under Voltage Protection (UVP)

A UVP circuit monitors the VFB voltage to detect an under voltage event. If the VFB voltage is below this threshold for more than 20  $\mu$ s, a UVP fault is set and the device will enter hiccup mode.

### Over Current Protection (OCP)

The NCP3231N over current protection scheme senses the peak freewheeling current in the low-side FET (LSOCP) after a blanking time of 150 ns as shown in Figure 23. The low-side FET drain-to-source voltage,  $V_{DS}$ , is compared against the voltage of a fixed, internal current source, ISET and a user-selected resistor, RSET. Voltage across the low-side FET is sensed from the VSW pin to GND.

After an OCP detection, the NCP3231N keeps the high-side FET off until the Low-side FET current falls below the trip point again and the next clock cycle occurs. An internal OCP counter will count up to 3 consecutive LSOCP events. After the third consecutive count, the device enters hiccup mode.

To prevent nuisance trips, there is a backup counter that will reset the OCP counter after 7 consecutive cycles without an LSOCP trigger. The backup counter is reset and then started again after each OCP trip until the third OCP count as stated above occurs.

## Over Current Protection Threshold

The NCP3231N allows the user to adjust the LSOCP threshold with an external resistor, RSET. This resistor, along with an internal temperature compensated current source, ISET, sets the current limit reference voltage for the LSOCP comparator.

Internally, a current sense circuit samples the voltage from VSW to GND. This voltage is then multiplied by a factor of 2 and compared against the ISET\*RSET voltage threshold.

The basic design equation for LSOCP trip point selection is:

$$\begin{aligned} RSET &= \frac{2 \times (i_{Load} + 0.5i_{Lpk-pk}) \times R_{dson}}{ISET} \quad (\text{eq. 2}) \\ &= 2 \times 67 \times (i_{Load} + 0.5i_{Lpk-pk}) \end{aligned}$$

In this equation,  $i_{Load}$  is the over current protection point of the load current,  $i_{Lpk-pk}$  is the peak to peak value of inductor current, and for example, when input voltage is 12 V, output voltage is 3.3 V, switching frequency is 500 kHz and inductor value is 330 nH, the peak to peak value of inductor current is 14.5 A. ISET is temperature compensated current source proportional to the on-resistance of LS MOSFET,  $R_{dson}$ , the ratio of  $R_{dson}$  to ISET is about 67.

In case RSET is not connected, the device switches the OCP threshold to a fixed 300 mV value: an internal safety clamp on ISET is triggered as soon as the ISET voltage reaches 600 mV, enabling the 300 mV fixed threshold.

## Thermal Shutdown (TSD)

The NCP3231N protects itself from overheating with an internal thermal monitoring circuit. If the junction temperature exceeds the thermal shutdown threshold both the upper and lower MOSFETs will be shut OFF. Once the temperature drops below the falling hysteresis threshold, the voltage at the COMP pin will be pulled below the ramp valley voltage and a soft-start will be initiated.

## Power Good Monitor (PG)

NCP3231N monitors the output voltage and signal when the output is out of regulation or during a non-regulated pre-bias condition, or fault condition. When the output voltage is within the OVP and UVP thresholds, the power

good pin is a high impedance output. If the NCP3231N detects an OCP, OVP, UVP, OTS, TSD or is in soft start, it pulls PG pin low. The PG pin is an open drain 10 mA pull down output.

## Layout Guidelines

When laying out a power PCB for the NCP3231N there are several general key points and special key points to consider:

*General Layout Guide:* these are the common techniques for high frequency high power board layout design.

*Base component placement:* High current path components should be placed to keep the current path as tight as possible. Placement of components on the bottom of the board such as input or output decoupling can add loop inductance.

*Ground Return for Power and Signals:* Solid, uninterrupted ground planes must be present and adjacent to the high current path.

*Copper Shapes on Component Layers:* Large copper planes on one or multiple layers with adequate vias will increase thermal transfer, reduce copper conduction losses, and minimize loop inductance. Greater than 20 A designs require 2~3 layer shapes or more, increasing the number of layers will only improvement performance.

*Via Placement for Power and Ground:* Place enough vias to adequately connect outer layers to inner layers for thermal transfer and to minimize added inductance in layer transition. Multiple vias should be placed near important components like input ceramics and output ceramic capacitors.

*Key Signal Routes:* Do not route sensitive signals, such as FB near or under noisy nets such as the switch node VSW and BST node, to reduce noise coupling effects on the sensitive lines.

*Special Layout Guide:* please pay attention to the special requirement of layout guide.

To improve the High-side OCP accuracy, users should connect VCC and VIN directly and do not place any type of filter or resistor between these two pins.

To improve the Low-side OCP accuracy, users should use single ground connection instead of separate analog ground and power ground. Make sure that the inner layers (at least 2nd layer, 3rd layer and 4th layer) are dedicated for ground plane. Do not use other copper planes to cut or interrupt the shape of ground plane, which may add more parasitic components to affect the sensing accuracy.

# NCP3231N

## PACKAGE DIMENSIONS

QFN40 6x6, 0.5P  
CASE 485FJ  
ISSUE O

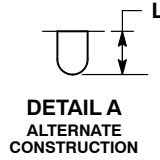
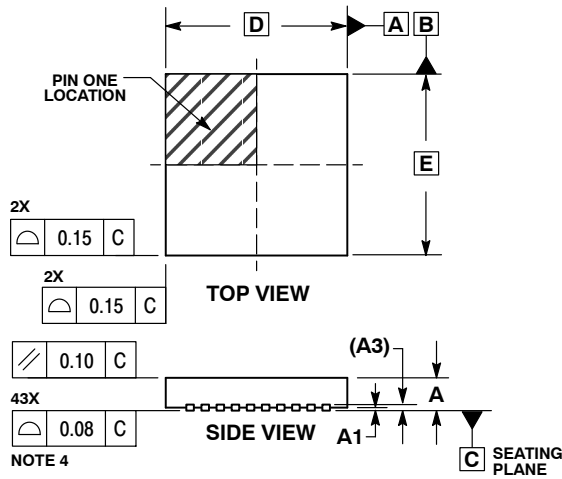

**NOTES:**

1. DIMENSIONING AND TOLERANCING PER ASME Y14.5M, 1994.
2. CONTROLLING DIMENSIONS: MILLIMETERS.
3. DIMENSION b APPLIES TO PLATED TERMINAL AND IS MEASURED BETWEEN 0.15 AND 0.30mm FROM TERMINAL
4. COPLANARITY APPLIES TO THE EXPOSED PAD AS WELL AS THE TERMINALS.
5. POSITIONAL TOLERANCE APPLIES TO ALL THREE EXPOSED PADS.

DIM	MILLIMETERS	
	MIN	MAX
A	0.80	1.00
A1	---	0.05
A3	0.20	REF
b	0.18	0.30
D	6.00	BSC
D2	2.30	2.50
D3	1.40	1.60
E	6.00	BSC
E2	4.30	4.50
E3	1.90	2.10
E4	1.64	1.84
e	0.50	BSC
G	2.20	BSC
K	0.20	---
L	0.30	0.50

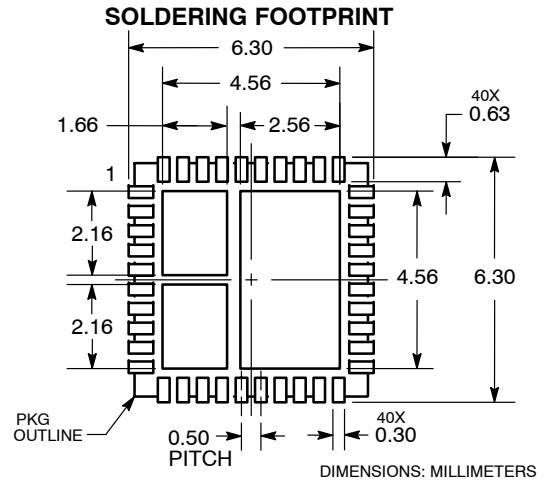
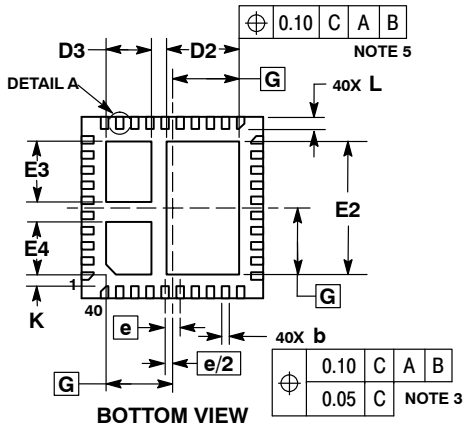

ON Semiconductor and are trademarks of Semiconductor Components Industries, LLC dba ON Semiconductor or its subsidiaries in the United States and/or other countries. ON Semiconductor owns the rights to a number of patents, trademarks, copyrights, trade secrets, and other intellectual property. A listing of ON Semiconductor's product/patent coverage may be accessed at [www.onsemi.com/site/pdf/Patent-Marketing.pdf](http://www.onsemi.com/site/pdf/Patent-Marketing.pdf). ON Semiconductor reserves the right to make changes without further notice to any products herein. ON Semiconductor makes no warranty, representation or guarantee regarding the suitability of its products for any particular purpose, nor does ON Semiconductor assume any liability arising out of the application or use of any product or circuit, and specifically disclaims any and all liability, including without limitation special, consequential or incidental damages. Buyer is responsible for its products and applications using ON Semiconductor products, including compliance with all laws, regulations and safety requirements or standards, regardless of any support or applications information provided by ON Semiconductor. "Typical" parameters which may be provided in ON Semiconductor data sheets and/or specifications can and do vary in different applications and actual performance may vary over time. All operating parameters, including "Typicals" must be validated for each customer application by customer's technical experts. ON Semiconductor does not convey any license under its patent rights nor the rights of others. ON Semiconductor products are not designed, intended, or authorized for use as a critical component in life support systems or any FDA Class 3 medical devices or medical devices with a same or similar classification in a foreign jurisdiction or any devices intended for implantation in the human body. Should Buyer purchase or use ON Semiconductor products for any such unintended or unauthorized application, Buyer shall indemnify and hold ON Semiconductor and its officers, employees, subsidiaries, affiliates, and distributors harmless against all claims, costs, damages, and expenses, and reasonable attorney fees arising out of, directly or indirectly, any claim of personal injury or death associated with such unintended or unauthorized use, even if such claim alleges that ON Semiconductor was negligent regarding the design or manufacture of the part. ON Semiconductor is an Equal Opportunity/Affirmative Action Employer. This literature is subject to all applicable copyright laws and is not for resale in any manner.

### PUBLICATION ORDERING INFORMATION

**LITERATURE FULFILLMENT:**

Literature Distribution Center for ON Semiconductor  
19521 E. 32nd Pkwy, Aurora, Colorado 80011 USA  
Phone: 303-675-2175 or 800-344-3860 Toll Free USA/Canada  
Fax: 303-675-2176 or 800-344-3867 Toll Free USA/Canada  
Email: [orderlit@onsemi.com](mailto:orderlit@onsemi.com)

**N. American Technical Support:** 800-282-9855 Toll Free  
USA/Canada  
**Europe, Middle East and Africa Technical Support:**  
Phone: 421 33 790 2910

**ON Semiconductor Website:** [www.onsemi.com](http://www.onsemi.com)

**Order Literature:** <http://www.onsemi.com/orderlit>

For additional information, please contact your local Sales Representative