

# NCP81247

## Dual Output 4 & 2 Phase Controller with SVID Interface for Desktop and Notebook CPU Applications

The NCP81247 dual output four plus two phase buck solution is optimized for Intel's IMVP8 CPUs. The controller combines true differential voltage sensing, differential inductor DCR current sensing, input voltage feed-forward, and adaptive voltage positioning to provide accurately regulated power for notebook applications.

The control system is based on Dual-Edge pulse-width modulation (PWM) combined with DCR current sensing providing an ultra fast initial response to dynamic load events and reduced system cost. The NCP81247 provides the mechanism to shed phases during light load operation and can auto frequency scale in light load conditions while maintaining excellent transient performance.

Dual high performance operational error amplifiers are provided to simplify compensation of the complete system. Patented Dynamic Reference Injection further simplifies loop compensation by eliminating the need to compromise between closed-loop transient response and Dynamic VID performance. Patented Total Current Summing provides highly accurate current monitoring for droop and digital current monitoring.

### Features

- Meets Intel's IMVP8 Specification
- Current Mode Dual Edge Modulation for Fast Initial Response to Transient Loading
- Dual High Performance Operational Error Amplifier
- One Digital Soft Start Ramp for Both Rails
- Dynamic Reference Injection
- Accurate Total Summing Current Amplifier
- DAC with Droop Feed-forward Injection
- Dual High Impedance Differential Voltage and Total Current Sense Amplifiers
- Phase-to-Phase Dynamic Current Balancing
- "Lossless" DCR Current Sensing for Current Balancing
- Summed Compensated Inductor Current Sensing for Droop
- True Differential Current Balancing Sense Amplifiers for Each Phase
- Adaptive Voltage Positioning (AVP)
- Switching Frequency Range of 180 KHz – 1.17 MHz
- Startup into Pre-Charged Loads while Avoiding False OVP



ON Semiconductor®

[www.onsemi.com](http://www.onsemi.com)

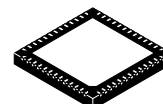

1 52  
**QFN52**  
**MN SUFFIX**  
**CASE 485BE**

### MARKING DIAGRAM

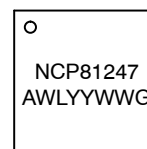

NCP81247 = Specific Device Code  
A = Assembly Location  
WL = Wafer Lot  
YY = Year  
WW = Work Week  
G = Pb-Free Package

### ORDERING INFORMATION

Device	Package	Shipping†
NCP81247MNTXG	QFN52 (Pb-Free)	2500 / Tape & Reel

†For information on tape and reel specifications, including part orientation and tape sizes, please refer to our Tape and Reel Packaging Specification Brochure, BRD8011/D.

- Power Saving Phase Shedding
- Vin Feed Forward Ramp Slope
- Over Voltage Protection (OVP) & Under Voltage Protection (UVP)
- Over Current Protection (OCP)
- Dual Power Good Output with Internal Delays
- Pb-free and Halide-free Packages are Available

### Applications

- IMVP8 Desktop
- Gaming

# NCP81247

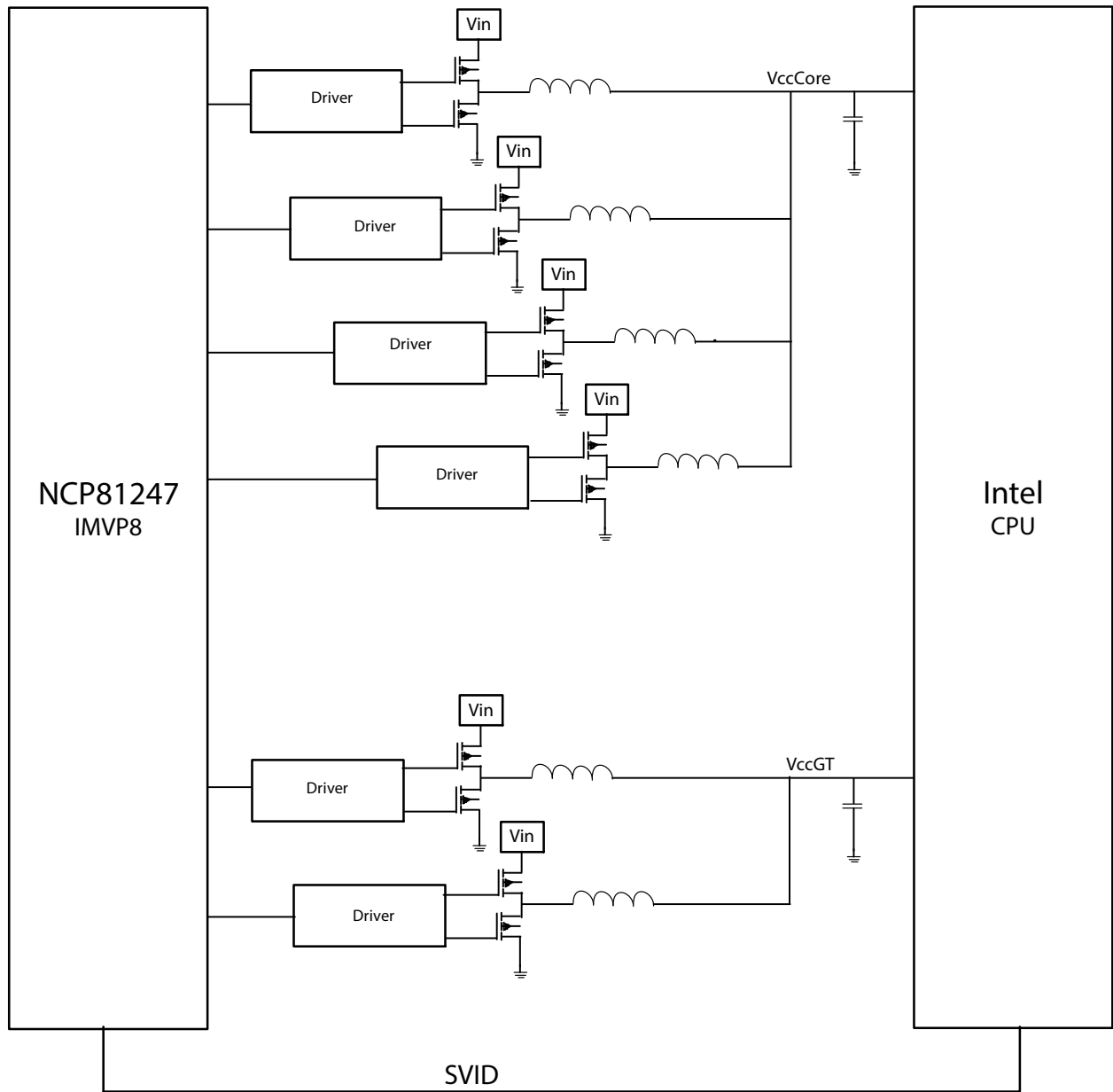
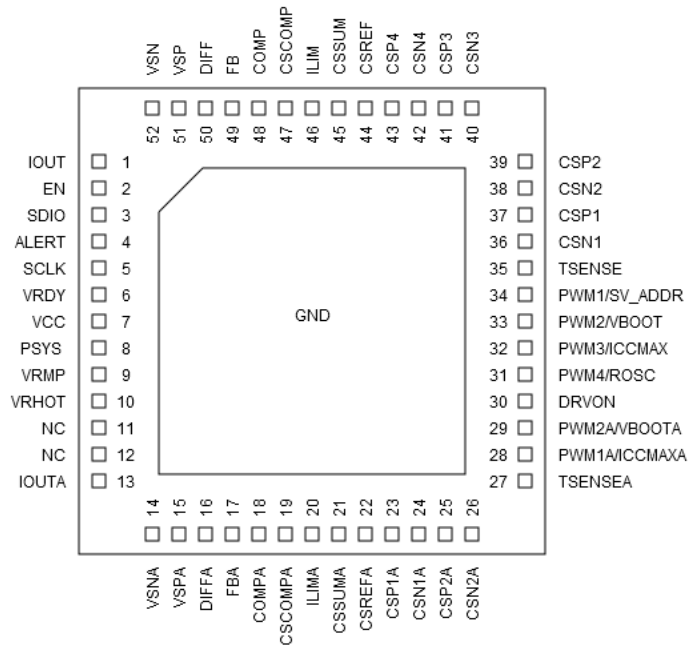

Figure 1. Block Diagram

# NCP81247



**Table 1. QFN52 PIN DESCRIPTION**

Pin No.	Symbol	Description
1	IOUT	Total output current monitor for four-phase regulator
2	EN	Enable. High enables both rails
3	SDIO	Serial VID data interface
4	ALERT	Serial VID ALERT
5	SCLK	Serial VID clock
6	VR_RDY	VR_RDY indicates both rails are ready to accept SVID commands
7	VCC	Power for the internal control circuits. A decoupling capacitor is connected from this pin to ground
8	PSYS	System power signal input
9	VRMP	Feed-forward input of Vin for the ramp-slope compensation. The current fed into this pin is used to control the ramp of the PWM slopes
10	VR_HOT	OD output. Indicates high VR temperature threshold crossed
11	NC	
12	NC	
13	IOUTA	Total output current monitor for two-phase regulator
14	VSNA	Differential output voltage positive sense for two-phase rail
15	VSPA	Differential output voltage negative sense for two-phase rail
16	DIFFA	Output of the two-phase regulator's differential remote sense amplifier
17	FBA	Error amplifier voltage feedback for two-phase regulator
18	COMPA	Output of the error amplifier and the inverting inputs of the PWM comparators for two-phase regulator
19	CSCOMPA	Output of total-current-sense amplifier for two-phase regulator
20	ILIMA	Over-current threshold setting – programmed with a resistor to CSCOMPA for two-phase regulator
21	CSSUMA	Inverting input of total-current-sense amplifier for two-phase regulator
22	CSREFA	Total-current-sense amplifier reference voltage input for two-phase regulator
23	CSP1A	Non-inverting input to current-balance amplifier for Phase 1 of two-phase regulator.
24	CSN1A	Inverting input to the current-balance amplifier for Phase 1 of two-phase regulator.

# NCP81247

**Table 1. QFN52 PIN DESCRIPTION**

Pin No.	Symbol	Description
25	CSP2A	Non-inverting input to current-balance amplifier for Phase 2 of the two-phase regulator. Pull this pin to Vcc to disable Phase 2.
26	CSN2A	Inverting input to the current-balance amplifier for Phase 2 of the two-phase regulator
27	TSENSEA	Temperature sense input for two-phase regulator
28	PWM1A / ICCMAXA	PWM1 output for two-phase regulator During startup, ICCMAX for two-phase regulator is programmed with a pull-down resistor
29	PWM2A / VBOOTA	PWM2 output for two-phase regulator Pin-program for two-phase Vboot.
30	DRON	External FET driver enable for discrete driver or ON Semiconductor DrMOS
31	PWM4 / ROSC	PWM4 output for four-phase regulator / Pulldown on this pin programs the operating frequency for both rails
32	PWM3 / ICCMAX	PWM3 output for four-phase regulator / Pulldown on this pin programs ICCMAX for four-phase rail during startup
33	PWM2 / VBOOT	PWM2 output for four-phase regulator / Pin-program for four-phase Vboot.
34	PWM1 / SV_ADDR	PWM1 output for four-phase regulator / Pulldown on this pin configures SVID address
35	TSENSE	Temperature sense input for four-phase regulator
36	CSN1	Differential current sense negative for Phase 1 of four-phase rail
37	CSP1	Differential current sense positive for Phase 1 of four-phase rail
38	CSN2	Differential current sense negative for Phase 2 of four-phase rail
39	CSP2	Differential current sense positive for Phase 2 of four-phase rail
40	CSN3	Differential current sense negative for Phase 3 of four-phase rail
41	CSP3	Differential current sense positive for Phase 3 of four-phase rail
42	CSN4	Differential current sense negative for Phase 4 of four-phase rail
43	CSP4	Differential current sense positive for Phase 4 of four-phase rail
44	CSREF	Total-current-sense amplifier reference voltage input for four-phase regulator
45	CSSUM	Inverting input of total-current-sense amplifier for four-phase regulator
46	ILIM	Over-current threshold setting – programmed with a resistor to CSCOMP for four-phase regulator
47	CSCOMP	Output of total-current-sense amplifier for four-phase regulator
48	COMP	Output of the error amplifier and the inverting inputs of the PWM comparators for four-phase regulator
49	FB	Error amplifier voltage feedback for four-phase regulator
50	DIFF	Output of the four-phase regulator's differential remote sense amplifier
51	VSP	Differential output voltage sense positive for four-phase regulator
52	VSN	Differential output voltage sense negative for four-phase regulator
53	Flag	GND

# NCP81247

**Table 2. ABSOLUTE MAXIMUM RATINGS**

Pin Symbol	V <sub>MAX</sub>	V <sub>MIN</sub>	I <sub>SOURCE</sub>	I <sub>SINK</sub>
COMP, COMPA	VCC + 0.3 V	-0.3 V	2 mA	2 mA
CSCOMP, CSCOMPA	VCC + 0.3 V	-0.3 V	2 mA	2 mA
DIFF, DIFFA	VCC + 0.3 V	-0.3 V	2 mA	2 mA
PWM1, PWM2, PWM3, PWM4, PWM1A, PWM2A	VCC + 0.3 V	-0.3 V		
VSN, VSNA	GND + 300 mV	GND - 300 mV	1 mA	1 mA
VRDY	VCC + 0.3 V	-0.3 V	2 mA	2 mA
VCC	6.5 V	-0.3 V		
VRMP	+25 V	-0.3 V		
All Other Pins	VCC + 0.3 V	-0.3 V		

Stresses exceeding those listed in the Maximum Ratings table may damage the device. If any of these limits are exceeded, device functionality should not be assumed, damage may occur and reliability may be affected.

\*All signals referenced to GND unless noted otherwise.

**Table 3. THERMAL INFORMATION**

Description	Symbol	Value	Unit
Thermal Characteristic - QFN Package (Note 1)	R <sub>JA</sub>	68	°C/W
Operating Junction Temperature Range (Note 2)	T <sub>J</sub>	-40 to +125	°C
Operating Ambient Temperature Range		-40 to +100	°C
Maximum Storage Temperature Range	T <sub>STG</sub>	-40 to +150	°C
Moisture Sensitivity Level - QFN Package	MSL	1	
ESD Human Body Model	HBM	2500	V
ESD Machine Model	MM	200	V
ESD Charged device model	CDM	1000	V

\*The maximum package power dissipation must be observed.

1. JESD 51-5 (1S2P Direct-Attach Method) with 0 LFM
2. JESD 51-7 (1S2P Direct-Attach Method) with 0 LFM

**Table 4. NCP81247 (4+2) ELECTRICAL CHARACTERISTICS**

Unless otherwise stated: -40°C < T<sub>A</sub> < 100°C; 4.75 V < VCC < 5.25 V; C<sub>VCC</sub> = 0.1 μF

Parameter	Test Conditions	Min	Typ	Max	Units
<b>ERROR AMPLIFIER</b>					
Input Bias Current		-400		400	nA
Open Loop DC Gain	CL = 20 pF to GND, RL = 10 KΩ to GND		80		dB
Open Loop Unity Gain Bandwidth	CL = 20 pF to GND, RL = 10 KΩ to GND		20		MHz
Slew Rate	ΔVin = 100 mV, G = -10 V/V, ΔVout = 0.75 V - 1.52 V, CL = 20 pF to GND, DC Load = 10 k to GND		20		V/μs
Maximum Output Voltage	I <sub>SOURCE</sub> = 2.0 mA	3.5	-	-	V
Minimum Output Voltage	I <sub>SINK</sub> = 2.0 mA	-	-	1	V
<b>DIFFERENTIAL SUMMING AMPLIFIER</b>					
Input Bias Current		-400	-	400	nA
VSP Input Voltage Range		-0.3	-	3.0	V
VSN Input Voltage Range		-0.3	-	0.3	V
-3 dB Bandwidth	CL = 20 pF to GND, RL = 10 KΩ to GND		12		MHz

# NCP81247

**Table 4. NCP81247 (4+2) ELECTRICAL CHARACTERISTICS**

Unless otherwise stated:  $-40^{\circ}\text{C} < T_A < 100^{\circ}\text{C}$ ;  $4.75\text{ V} < V_{CC} < 5.25\text{ V}$ ;  $C_{VCC} = 0.1\ \mu\text{F}$

Parameter	Test Conditions	Min	Typ	Max	Units
<b>DIFFERENTIAL SUMMING AMPLIFIER</b>					
Closed Loop DC gain VS to DIFF	$VS_+ \text{ to } VS_- = 0.5 \text{ to } 1.3\text{ V}$		1		V/V
Droop Accuracy	CSREF-DROOP = 80 mV DAC = 0.8 V to 1.2 V	-42	-40	-38	mV
Maximum Output Voltage	$I_{SOURCE} = 2\text{ mA}$	3.0	-	-	V
Minimum Output Voltage	$I_{SINK} = 2\text{ mA}$	-	-	0.5	V

<b>CURRENT SUMMING AMPLIFIER</b>					
Offset Voltage (Vos)		-300		300	$\mu\text{V}$
Input Bias Current	CSSUM = CSREF = 1.2 V	-7.5		7.5	$\mu\text{A}$
Open Loop Gain			80		dB
Current Sense Unity Gain Bandwidth	$C_L = 20\text{ pF to GND}$ , $R_L = 10\text{ K}\Omega \text{ to GND}$		10		MHz
Maximum CSCOMP (A) Output Voltage	$I_{SOURCE} = 2\text{ mA}$	3.5	-	-	V
Minimum CSCOMP(A) Output Voltage	$I_{SINK} = 2\text{ mA}$	-	-	0.1	V

<b>CURRENT BALANCE AMPLIFIER</b>					
Input Bias Current		-50	-	50	nA
Common Mode Input Voltage Range	CSPx = CSREF	0	-	2.5	V
Differential Mode Input Voltage Range	CSNx = 1.2 V	-	-	100	mV
Closed loop Input Offset Voltage Matching	CSPx = 1.2 V, Measured from the average	-1.5	-	1.5	mV
Current Sense Amplifier Gain	$0\text{ V} < \text{CSPx} < 0.1\text{ V}$	5.7	6.0	6.3	V/V
Multiphase Current Sense Gain Matching	CSREF = CSP = 10 mV to 30 mV		$\pm 3$		%
-3 dB Bandwidth	Guaranteed by simulation		8		MHz

<b>BIAS SUPPLY</b>					
Supply Voltage Range		4.75		5.25	V
VCC Quiescent Current	PS0			60	mA
VCC Quiescent Current	PS1			60	mA
VCC Quiescent Current	PS2			55	mA
VCC Quiescent Current	PS3		35		mA
VCC Quiescent Current	PS4 (@ 25°C)		250		$\mu\text{A}$
UVLO Threshold	VCC rising			4.5	V
	VCC falling	3.8			V
VCC UVLO Hysteresis		90	300	450	mV

<b>VRMP</b>					
Supply Range		4.5		20	V
VRMP UVLO Threshold	VRMP rising			4.25	V
	VRMP falling	3			V
VRMP UVLO Hysteresis			800		mV

<b>DAC SLEW RATE</b>					
Soft Start/Slow Slew Rate			1/2 SR Fast		mv/ $\mu\text{s}$
Slew Rate Fast			>10		mv/ $\mu\text{s}$

# NCP81247

**Table 4. NCP81247 (4+2) ELECTRICAL CHARACTERISTICS**

Unless otherwise stated:  $-40^{\circ}\text{C} < T_A < 100^{\circ}\text{C}$ ;  $4.75\text{ V} < V_{CC} < 5.25\text{ V}$ ;  $C_{VCC} = 0.1\ \mu\text{F}$

Parameter	Test Conditions	Min	Typ	Max	Units
-----------	-----------------	-----	-----	-----	-------

### DAC SLEW RATE

AUX Soft Start/Slow Slew Rate			1/2 SR Fast		mv/ $\mu\text{s}$
AUX Slew Rate Fast			>10		mv/ $\mu\text{s}$

### ENABLE INPUT

Enable High Input Leakage Current		-1	0	1	$\mu\text{A}$
Upper Threshold	VUPPER	0.8			V
Lower Threshold	VLOWER			0.3	V
Enable Delay Time	Measure time from Enable transitioning HI, VBOOT is not 0 V			2.55	ms

### DRON

Output High Voltage	Sourcing 500 $\mu\text{A}$	3.0	-	-	V
Output Low Voltage	Sinking 500 $\mu\text{A}$	-	-	0.1	V
Pull Up Resistances			2.0		k $\Omega$
Rise/Fall Time	CL (PCB) = 20 pF, $\Delta V_o = 10\%$ to 90%	-	160		ns
Internal Pull Down Resistance	VCC = 0 V		70		k $\Omega$

### IOUT /IOUTA OUTPUT

Input Referred Offset Voltage	Ilimit to CSREF	-4		+4	mV
Output current max	Ilimit sink current 30 $\mu\text{A}$	285	300	315	$\mu\text{A}$
Current Gain	(Iout current)/(Ilimit Current) Rlim = 20 K, Riout = 5 K DAC = 0.8 V, 1.25 V, 1.52 V	9.5	10	10.5	

### OSCILLATOR

Switching Frequency Range		180		1170	kHz
Switching Frequency Accuracy	180 kHz < Fsw < 1170 kHz	-10	-	10	%

### PSYS

Input current max	rsys = 20 K			100	$\mu\text{A}$
ADC resolution	8 bit		0.4		$\mu\text{A}/\text{Bit}$
Register update rate			145		$\mu\text{s}$

### OUTPUT OVER VOLTAGE & UNDER VOLTAGE PROTECTION (OVP & UVP)

Over Voltage Threshold During Soft-Start	CSREF Rising		2.5		V
Over Voltage Threshold Above DAC	VSP rising	350	400	475	mV
Over Voltage Delay	VSP rising to PWMx low		50		ns
Under Voltage Threshold Below DAC-DROOP	VSP falling	370	400	425	mV
Under-voltage Hysteresis	VSP rising		50		mV
Under Voltage Threshold Below DAC-Droop	VSP falling	370	400	425	mV
Under-voltage Hysteresis	VSP rising		25		mV
Under-Voltage Delay			5		$\mu\text{s}$

### OVERCURRENT PROTECTION

ILIM Threshold Current (OCP shut-down after 50 $\mu\text{s}$ delay)	Main Rail, Rlim = 20 k $\Omega$	7.5	10	11.5	$\mu\text{A}$
---	---------------------------------	-----	----	------	---------------

# NCP81247

**Table 4. NCP81247 (4+2) ELECTRICAL CHARACTERISTICS**

Unless otherwise stated:  $-40^{\circ}\text{C} < T_A < 100^{\circ}\text{C}$ ;  $4.75\text{ V} < V_{CC} < 5.25\text{ V}$ ;  $C_{VCC} = 0.1\ \mu\text{F}$

Parameter	Test Conditions	Min	Typ	Max	Units
-----------	-----------------	-----	-----	-----	-------

### OVERCURRENT PROTECTION

ILIM Threshold Current (immediate OCP shutdown)	Main Rail, $R_{lim} = 20\text{ k}$	13	15	17	$\mu\text{A}$
ILIM Threshold Current (OCP shutdown after 50 $\mu\text{s}$ delay)	Main Rail, $R_{lim} = 20\text{ K}$ (N = number of phases in PS0 mode)		10/N		$\mu\text{A}$
ILIM Threshold Current (immediate OCP shutdown)	Main Rail, $R_{lim} = 20\text{ K}$ (N = number of phases in PS0 mode)		15/N		$\mu\text{A}$
ILIM Threshold Current (OCP shutdown after 50 $\mu\text{s}$ delay)	Auxiliary Rail, $R_{lim} = 20\text{ k}$	7.5	10	11.5	$\mu\text{A}$
ILIM Threshold Current (immediate OCP shutdown)	Auxiliary Rail, $R_{lim} = 20\text{ k}$	13	15	17	$\mu\text{A}$
ILIM Threshold Current (OCP shutdown after 50 $\mu\text{s}$ delay)	Auxiliary Rail $R_{lim} = 20\text{ K}$		10/N		$\mu\text{A}$
ILIM Threshold Current (immediate OCP shutdown)	Auxiliary Rail, $R_{lim} = 20\text{ K}$		15/N		$\mu\text{A}$

### MODULATORS (PWM COMPARATORS) FOR MAIN RAIL & AUXILIARY RAIL

PWM Min Pulse Width	$F_{sw} = 350\text{ kHz}$		60		ns
0% Duty Cycle	COMP voltage when the PWM outputs remain LO		1.3	-	V
100% Duty Cycle	COMP voltage when the PWM outputs remain HI $V_{RMP} = 12.0\text{ V}$	-	2.5	-	V
PWM Ramp Duty Cycle Matching	COMP = 2 V, PWM Ton matching		1		%
PWM Phase Angle Error	Between adjacent phases		$\pm 5$		deg

### TSENSE/TSENSEA

VR_HOT Assert Threshold	106°C Threshold		466		mV
VR_HOT Rising Threshold			490		mV
Alert Assertion Threshold	103°C Threshold		485		mV
Alert Rising Threshold			513		mV
Bias Current		115	120	135	$\mu\text{A}$

### VR\_HOT

Output Low Voltage	$I_{sink} = 20\text{ mA}$			0.3	V
Output Leakage Current	High Impedance State	-1.0	-	1.0	$\mu\text{A}$

### ADC

Voltage Range		0		2.5	V
Total Unadjusted Error (TUE)		-1.25		+1.25	%
Differential Nonlinearity (DNL)	8-bit			1	LSB
Power Supply Sensitivity			$\pm 1$		%
Conversion Time			10		$\mu\text{s}$
Round Robin			145		$\mu\text{s}$

### VRDY OUTPUT

Output Low Voltage	$I_{VDD(A)\_VRDY} = 4\text{ mA}$	-	-	0.3	V
Rise Time	External pull-up of 1 K $\Omega$ to 3.3 V, $C_{TOT} = 45\text{ pF}$ , $\Delta V_o = 10\%$ to 90%			150	ns
Fall Time	External pull-up of 1 K $\Omega$ to 3.3 V, $C_{TOT} = 45\text{ pF}$ , $\Delta V_o = 90\%$ to 10%			150	ns



# NCP81247

**Table 4. NCP81247 (4+2) ELECTRICAL CHARACTERISTICS**

Unless otherwise stated:  $-40^{\circ}\text{C} < T_A < 100^{\circ}\text{C}$ ;  $4.75\text{ V} < V_{CC} < 5.25\text{ V}$ ;  $C_{VCC} = 0.1\ \mu\text{F}$

Parameter	Test Conditions	Min	Typ	Max	Units
<b>VRDY OUTPUT</b>					
Output Voltage at Power-up	VRDY pulled up to 5 V via 2 K $\Omega$ enable low	-	-	0.1	V
Output Leakage Current When High	VRDY = 5.0 V	-1.0	-	1.0	$\mu\text{A}$
VR_RDY Delay (rising)	EN rising to VRDY (TA)		0	2.55	ms
VRDY Delay (falling)	From OVP		300		ns
	Enable falling to VR_RDY falling (TD+TE)			1.5	$\mu\text{s}$
<b>PWM (A), OUTPUTS</b>					
Output High Voltage	Sourcing 500 $\mu\text{A}$	$V_{CC} - 0.2\text{ V}$	-	-	V
Output Mid Voltage	No Load, PS0&1	1.9	2.0	2.1	V
Output Low Voltage	Sinking 500 $\mu\text{A}$	-	-	0.7	V
Rise and Fall Time	CL (PCB) = 50 pF, $\Delta V_o = 10\%$ to 90% of VCC	-	10		ns
Tri-State Output Leakage	Gx = 2.0 V, x = 1-2, EN = Low	-1.0	-	1.0	$\mu\text{A}$
<b>PHASE DETECTION</b>					
CSP2, CSP3, CSP4, CSP1A, CSP2A Pin Threshold Voltage		$V_{CC} - 0.2\text{ V}$			V
Phase Detect Timer			100		$\mu\text{s}$

3. Guaranteed by design or characterization data, not in production test.

## NCP81247

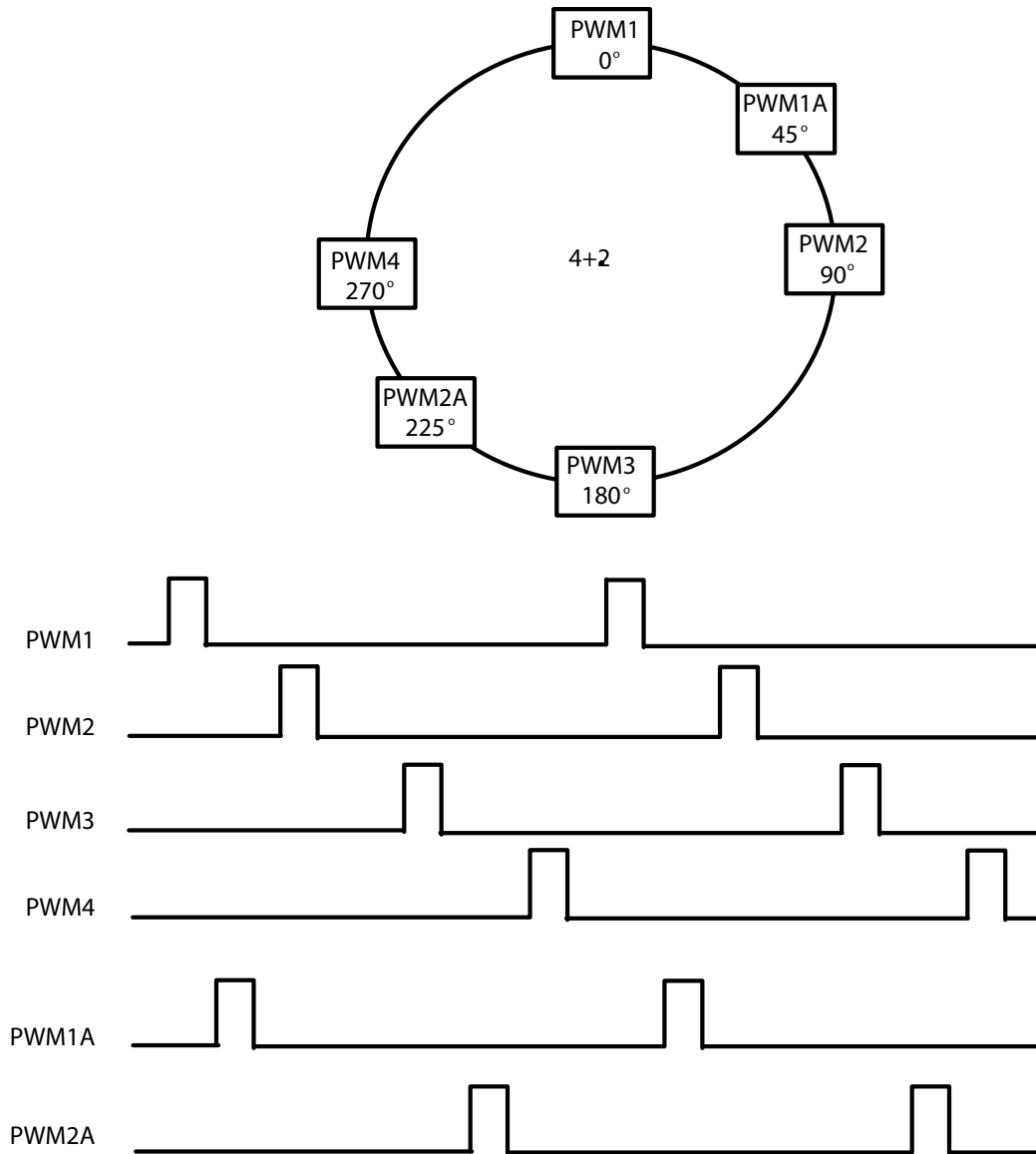

### Addresses/Phase Configuration

During startup, Pin 34 (PWM1/SV\_ADDR) is sampled to determine the SVID address and the phase configuration. More details in the table below:

Resistor	"main" SVID Address	"A" Address	4+2 or 3+3
10 kΩ	0 (Core)	1 (GT)	4+2
25 kΩ	1 (GT)	0 (Core)	4+2
45 kΩ	0 (Core)	2 (SA)	4+2
70 kΩ	1 (GT)	3 (GTUS)	4+2
95 kΩ	0 (Core)	1 (GT)	3+3
125 kΩ	1 (GT)	0 (Core)	3+3
165 kΩ	0 (Core)	2 (SA)	3+3
220 kΩ	1 (GT)	3 (GTUS)	3+3

The table above shows how to configure the part as either a 4+2 or a 3+3, however, if an alternative configuration such as 2+2 or 3+2 is desired then the phase that is no longer required must have its CSP pin shorted to 5 V. If any more than 2 phases are required on the GT rail then one of the 3+3 options in the table above must be selected.

I.e. if a 2+2 configuration is required, you must select a 4+2 configuration from the table above and then disable 2 phases from the Core rail by shorting CSP3 and CSP4 to 5 V.

If a 2+3 configuration is required, you will select a 3+3 configuration from the table above and disable the third phase of the Core rail by shorting CSP3 to 5 V. In this instance PWM4 is used on the GT rail.

**BOOT Voltage Programming**

The NCP81247 has a  $V_{BOOT}$  voltage register that can be externally programmed for both core and Auxiliary boot-up output voltages (pins 29 and 33). The  $V_{BOOT}$  voltage for main and auxiliary rails can be programmed with a resistor from  $V_{BOOT}$  and  $V_{BOOTA}$  pin to GND. Pin 33 (PWM2/ $V_{BOOT}$ ) is used to set the boot voltage for the main rail, pin 29 (PWM2A/ $V_{BOOTA}$ ) is used to configure the Auxiliary rail. On power up a 10  $\mu$ A current is sourced from these pins through a resistor connected to this pin and the resulting voltage is measured. Table 5 shows the resistor values that should be used and the corresponding  $V_{BOOT}$  options.

**Table 5.  $V_{BOOT}$  PROGRAMMABILITY**

Resistor	$V_{BOOT}$
10 k $\Omega$	0
30 k $\Omega$	0.8
60 k $\Omega$	1.05
100 k $\Omega$	1.2
160 k $\Omega$	1.4
220 k $\Omega$	1.5

**Precision Oscillator**

A programmable precision oscillator is provided. The clock oscillator serves as the master clock to the ramp generator circuit. This oscillator is programmed by a resistor to ground on the ROSC pin. The oscillator frequency range is between 180 KHz/phase to 1.17 MHz/phase. The ROSC pin provides approximately 2 V out and the source current is mirrored into the internal ramp oscillator. Available frequency options are as follows:

Resistor (k $\Omega$ )	Frequency (kHz)
10	180
14.7	225
20	270
26.1	315
33.2	360
41.2	405
49.9	450
60.4	495
71.5	540
84.5	630
100	720
118.3	810
136.6	900
157.7	990
182.1	1080
249	1170

**PSYS**

The psys pin is an analog input to the NCP81247. It is a system input power monitor that facilitates the monitoring of the total platform system power. The system power is sensed at the platform charging device, the NCP81247 facilitates reporting back current and through the SVID interface at address 0Dh.

**PSYS Disable**

The PSYS feature can be disabled by pulling the PSYS pin to 5 V.

**Phase Disable**

If a lower number of phases is required then phases can be disabled by pulling the relevant CSP pin directly to 5 V. For the Core rail here are the options for active phases:

4 Phase	All phases active
3 Phase	PWM4 is disabled by connecting CSP4 to 5 V.
2 Phase	PWM2 and PWM4 are disabled by connecting CSP2 and CSP4 to 5 V.
1 Phase	Only PWM1 is active, CSP2, CSP3 and CSP4 are tied to 5 V.

For the GT rail PWM1A & PWM2A can be disabled by connecting CSP1A & CSP2A to 5 V.

**Remote Sense Amplifier**

A high performance high input impedance true differential amplifier is provided to accurately sense the output voltage of the regulator. The VSP and VSN inputs should be connected to the regulator’s output voltage sense points. The remote sense amplifier takes the difference of the output voltage with the DAC voltage and adds the droop voltage to

$$V_{DIFOUT} = (V_{VSP} - V_{VSN}) + (1.3\text{ V} - V_{DAC}) + (V_{DROOP} - V_{CSREF})$$

This signal then goes through a standard error compensation network and into the inverting input of the error amplifier. The non-inverting input of the error amplifier is connected to the same 1.3 V reference used for the differential sense amplifier output bias.

**High Performance Voltage Error Amplifier**

A high performance error amplifier is provided for high bandwidth transient performance. A standard type III compensation circuit is normally used to compensate the system.

**Differential Current Feedback Amplifiers**

Each phase has a low offset differential amplifier to sense that phase current for current balance. The inputs to the CSNx and CSPx pins are high impedance inputs. It is recommended that any external filter resistor RCSN does not exceed 10 kΩ to avoid offset issues with leakage current. It is also recommended that the voltage sense element be no less than 0.5 mΩ for accurate current balance. Fine tuning of this time constant is generally not required. The individual phase current is summed into the PWM comparator feedback this way current is balanced via a current mode control approach.

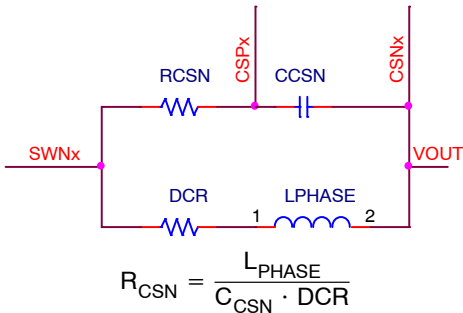

**Total Current Sense Amplifier**

The NCP81247 uses a patented approach to sum the phase currents into a single temperature compensated total current signal. This signal is then used to generate the output voltage droop, total current limit, and the output current monitoring functions. The total current signal is floating with respect to CSREF. The current signal is the difference between CSCOMP and CSREF. The Ref(n) resistors sum the signals from the output side of the inductors to create a low impedance virtual ground. The amplifier actively filters and gains up the voltage applied across the inductors to recover

the voltage drop across the inductor series resistance (DCR). Rth is placed near an inductor to sense the temperature of the inductor. This allows the filter time constant and gain to be a function of the Rth NTC resistor and compensate for the change in the DCR with temperature.

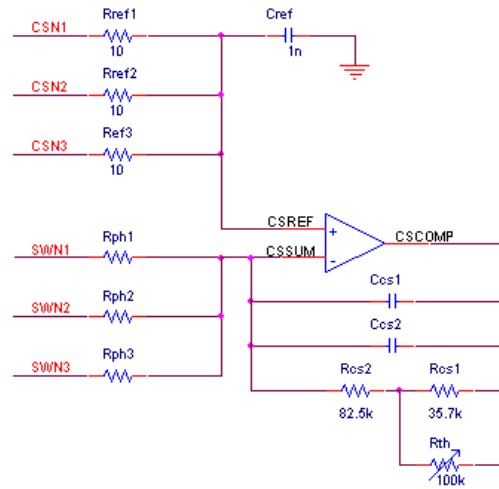

The DC gain equation for the current sensing:

$$V_{CSCOMP-CSREF} = \frac{Rcs2 + \frac{Rcs1 \cdot Rth}{Rcs1 + Rth}}{Rph} \cdot (I_{outTotal} \cdot DCR)$$

Set the gain by adjusting the value of the Rph resistors. The DC gain should be set to the output voltage droop. If the voltage from CSCOMP to CSREF is less than 100 mV at ICCMAX then it is recommend increasing the gain of the CSCOMP amp. This is required to provide a good current signal to offset voltage ratio for the ILIMIT pin. When no droop is needed, the gain of the amplifier should be set to provide ~100 mV across the current limit programming resistor at full load. The values of Rcs1 and Rcs2 are set based on the 100 k NTC and the temperature effect of the inductor and should not need to be changed. The NTC should be placed near the closest inductor. The output voltage droop should be set with the droop filter divider.

The pole frequency in the CSCOMP filter should be set equal to the zero from the output inductor. This allows the circuit to recover the inductor DCR voltage drop current signal. Ccs1 and Ccs2 are in parallel to allow for fine tuning of the time constant using commonly available values. It is best to fine tune this filter during transient testing.

$$F_z = \frac{DCR@25C}{2 \cdot \pi \cdot L_{Phase}}$$

**Programming the Current Limit**

The NCP81247 compares a programmable current-limit set point to the voltage from the output of the current-summing amplifier. The level of current limit is set with the resistor from the ILIM pin to CSCOMP. The current through the external resistor connected between ILIM and CSCOMP is then compared to the internal current limit current ICL. If the current generated through this resistor into

the ILIM pin (Ilim) exceeds the internal current-limit threshold current (ICL), an internal latch-off counter starts, and the controller shuts down if the fault is not removed after 50 μs (shut down immediately for 150% load current) after which the outputs will remain disabled until the Vcc voltage or EN is toggled.

The voltage swing of CSCOMP cannot go below ground. This limits the voltage drop across the DCR through the current balance circuitry. An inherent per-phase current limit protects individual phases if one or more phases stop functioning because of a faulty component. The over-current limit is programmed by a resistor on the ILIM pin. The resistor value can be calculated by the following equations,

Equation related to the Rilim,:

$$R_{ILIM} = \frac{I_{LIM} \cdot DCR \cdot R_{CS} / R_{PH}}{I_{CL}}$$

Where ICL = 10 μA

**Programming DAC Feed-Forward Filter**

The DAC feed-forward implementation is realized by having a filter on the VSN pin. Programming Rvsn sets the gain of the DAC feed-forward and Cvsn provides the time constant to cancel the time constant of the system per the following equations. Cout is the total output capacitance and Rout is the output impedance of the system.

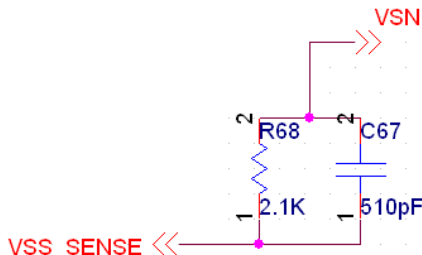

$$R_{vsn} = C_{out} \cdot R_{out} \cdot 453.6 \times 10^6$$

$$C_{vsn} = \frac{R_{out} \cdot C_{out}}{R_{vsn}}$$

**Programming DROOP**

The signals CSCOMP and CSREF are differentially summed with the output voltage feedback to add precision voltage droop to the output voltage.

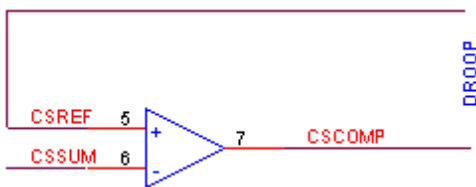

$$Droop = DCR * (R_{CS} / R_{ph})$$

**Programming IOU**

The IOU pin sources a current in proportion to the ILIMIT sink current. The voltage on the IOU pin is monitored by the internal A/D converter and should be scaled with an external resistor to ground such that a load equal to ICCMAX generates a 2.5 V signal on IOU. A pull-up resistor from 5 V VCC can be used to offset the IOU signal positive if needed.

$$R_{IOU} = \frac{2.5 V \cdot R_{LIMIT}}{10 \cdot \frac{R_{cs2} + \frac{R_{cs1} \cdot R_{th}}{R_{cs1} + R_{th}}}{R_{ph}} \cdot (I_{out_{ICC\_MAX}} \cdot DCR)}$$

**Programming ICC\_MAX**

A resistor to ground on the IMAX pin programs these registers at the time the part is enabled. 10 μA is sourced from these pins to generate a voltage on the program resistor. The value of the register is 1 A per LSB and is set by the equation below. The resistor value should be no less than 10 k.

$$ICC\_MAX_{21h} = \frac{R \cdot 10 \mu A \cdot 255 A}{2.5 V}$$

**Programming DAC Feed-Forward Filter**

The DAC feed-forward implementation is realized by having a filter on the VSN pin. Programming Rvsn sets the gain of the DAC feed-forward and Cvsn provides the time constant to cancel the time constant of the system per the following equations. Cout is the total output capacitance and Rout is the output impedance of the system.

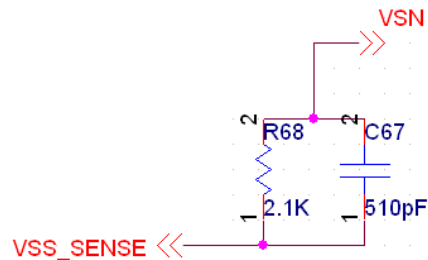

$$R_{vsn} = C_{out} \cdot R_{out} \cdot 453.6 \times 10^6$$

$$C_{vsn} = \frac{R_{out} \cdot C_{out}}{R_{vsn}}$$

**Programming TSENSE**

A temperature sense inputs are provided. A precision current is sourced out the output of the TSENSE pin to generate a voltage on the temperature sense network. The voltage on the temperature sense input is sampled by the internal A/D converter. A 10 k NTC similar to the TSM0B103H3371RZ should be used. Rcomp1 is mainly used for noise. See the specification table for the thermal sensing voltage thresholds and source current.

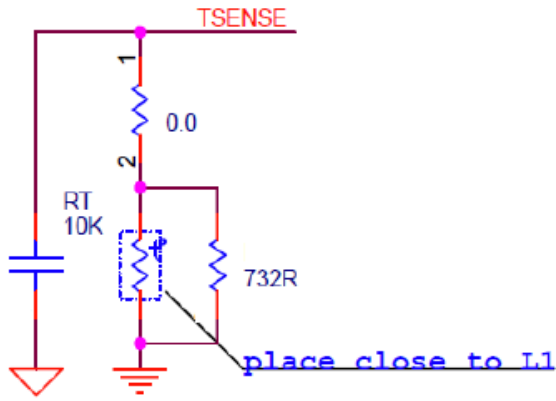

**Precision Oscillator**

A programmable precision oscillator is provided. The clock oscillator serves as the master clock to the ramp generator circuit. The oscillator frequency range is between 180 kHz/phase to 1170 kHz/phase. The operating frequency can be programmed using a resistor to ground from PWM4.

The oscillator generates triangle ramps that are 0.5~1.3 V in amplitude depending on the VRMP pin voltage to provide input voltage feed forward compensation. The ramps are equally spaced out of phase with respect to each other and the signal phase rail is set half way between phases 1 and 2 of the multi phase rail for minimum input ripple current.

**Programming the Ramp Feed-Forward Circuit**

The ramp generator circuit provides the ramp used by the PWM comparators. The ramp generator provides voltage feed-forward control by varying the ramp magnitude with respect to the VRMP pin voltage. The VRMP pin also has a 4 V UVLO function. The VRMP UVLO is only active after the controller is enabled. The VRMP pin is high impedance input when the controller is disabled.

The PWM ramp time is changed according to the following,

$$V_{RAMPpk-pk_{pp}} = 0.1 \cdot V_{VRMP}$$

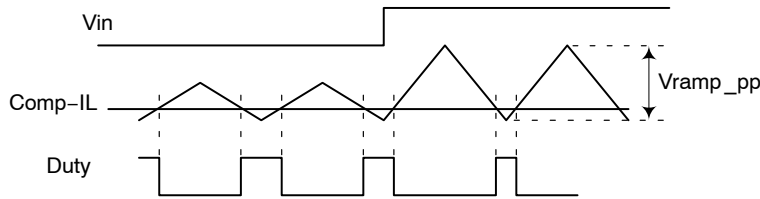

**PWM Comparators**

The non-inverting input of the comparator for each phase is connected to the summed output of the error amplifier (COMP) and each phase current (I\*DCR\*Phase Balance Gain Factor). The inverting input is connected to the oscillator ramp voltage with a 1.3 V offset. The operating input voltage range of the comparators is from 0 V to 3.0 V and the output of the comparator generates the PWM output.

During steady state operation, the duty cycle is centered on the valley of the sawtooth ramp waveform. The steady state duty cycle is still calculated by approximately  $V_{out}/V_{in}$ . During a transient event, the controller will operate in a hysteretic mode with the duty cycles pull in for all phases as the error amp signal increases with respect to all the ramps.

# NCP81247

## Protection Features

### Under Voltage Lockouts

There are several under voltage monitors in the system. Hysteresis is incorporated within the comparators. NCP81247 monitors the 5 V VCC supply. The gate driver monitors both the gate driver VCC and the BST voltage. When the voltage on the gate driver is insufficient it will pull

DRON low and prevents the controller from being enabled. The gate driver will hold DRON low for a minimum period of time to allow the controller to hold off its startup sequence. In this case the PWM is set to the MID state to begin soft start.

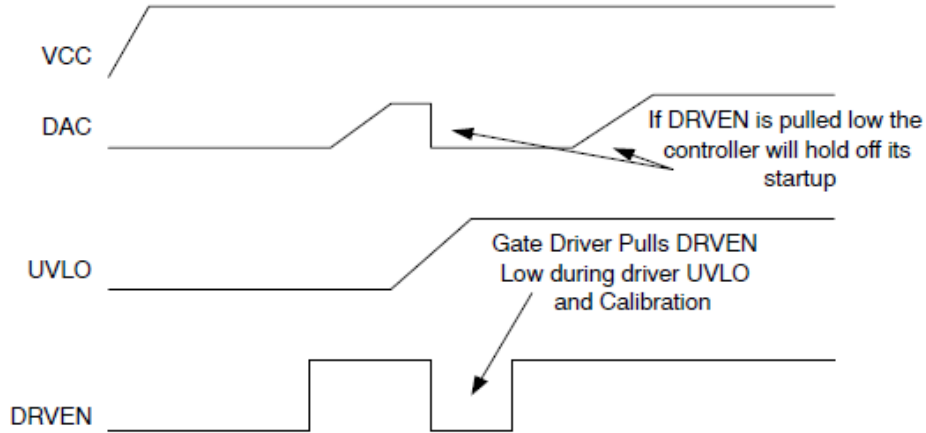

Figure 2. Gate Driver UVLO Restart

### Soft Start

Soft start is implemented internally. A digital counter steps the DAC up from zero to the target voltage based on the predetermined rate in the spec table. The PWM signals will start out open with a test current to collect data on phase count and for setting internal registers. After the configuration data is collected, if the controller is enabled

the PWMs will be set to 2.0 V MID state to indicate that the drivers should be in diode mode. DRON will then be asserted. As the DAC ramps the PWM outputs will begin to fire. Each phase will move out of the MID state when the first PWM pulse is produced. When the controller is disabled the PWM signal will return to the MID state.

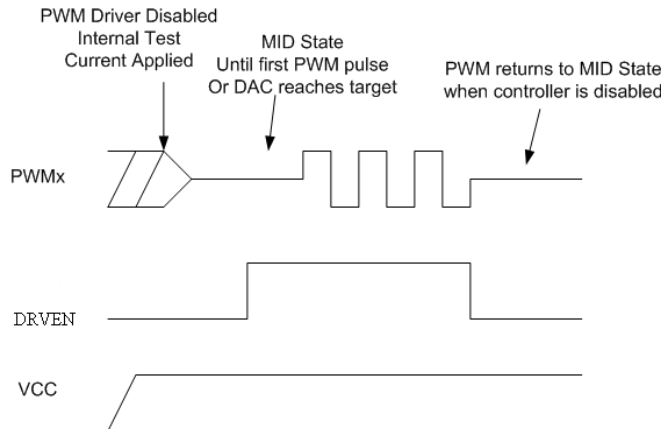

Figure 3. Soft-Start Sequence

### Over Voltage Protection

The output voltage is also monitored at the output of the differential amplifier for OVP. During normal operation, if the output voltage exceeds the DAC voltage (DAC voltage includes offset) by 400 mV, the VR\_RDY flag goes low, and

the output voltage will be ramped down to 0 V. At the same time, the high side gate drivers are all turned off and the low side gate drivers are all turned on. The part will stay in this mode until the Vcc voltage or EN is toggled.

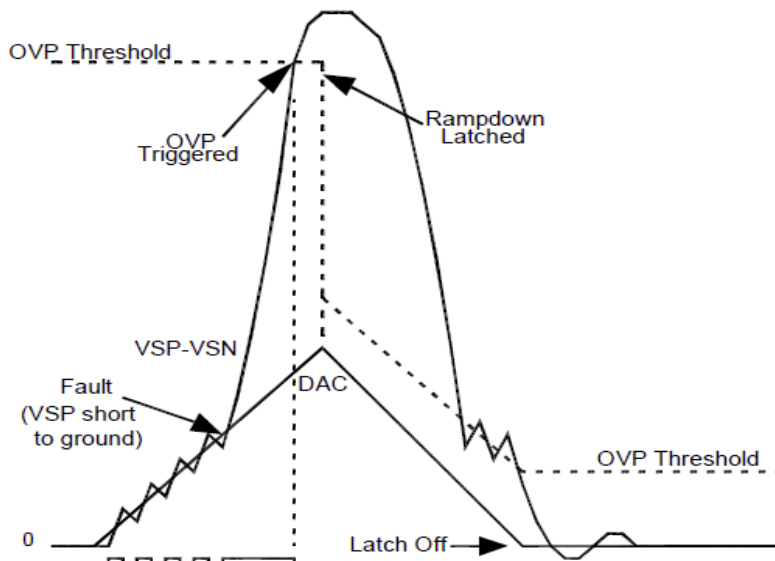

Figure 4. OVP Behavior at Startup

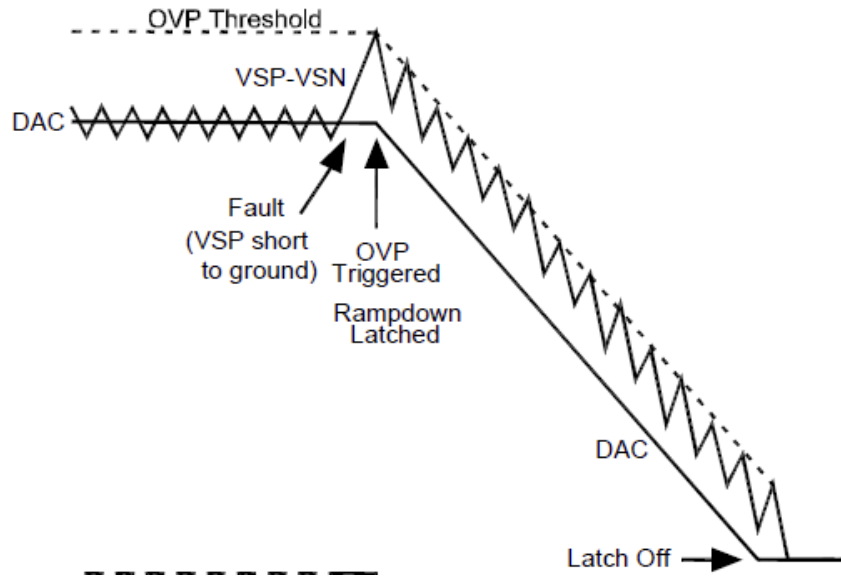

Figure 5. OVP During Normal Operation Mode



# NCP81247

## PACKAGE DIMENSIONS

QFN52 6x6, 0.4P  
CASE 485BE  
ISSUE B

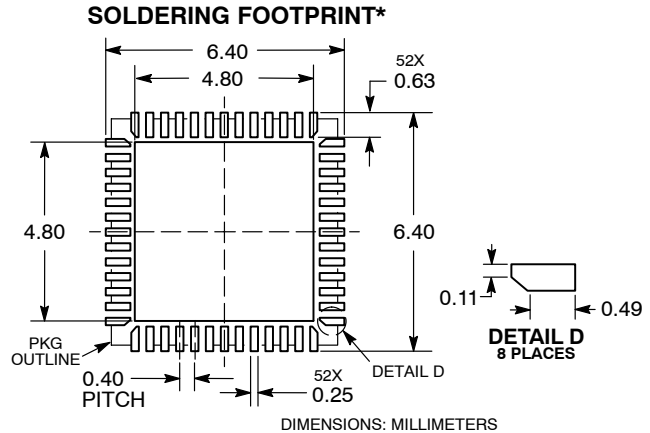
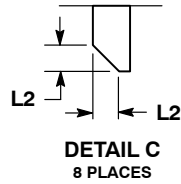
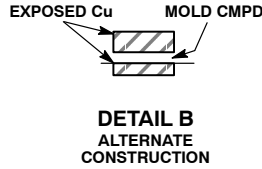
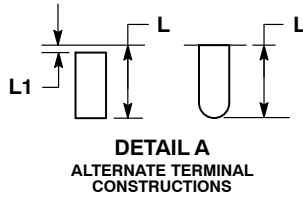
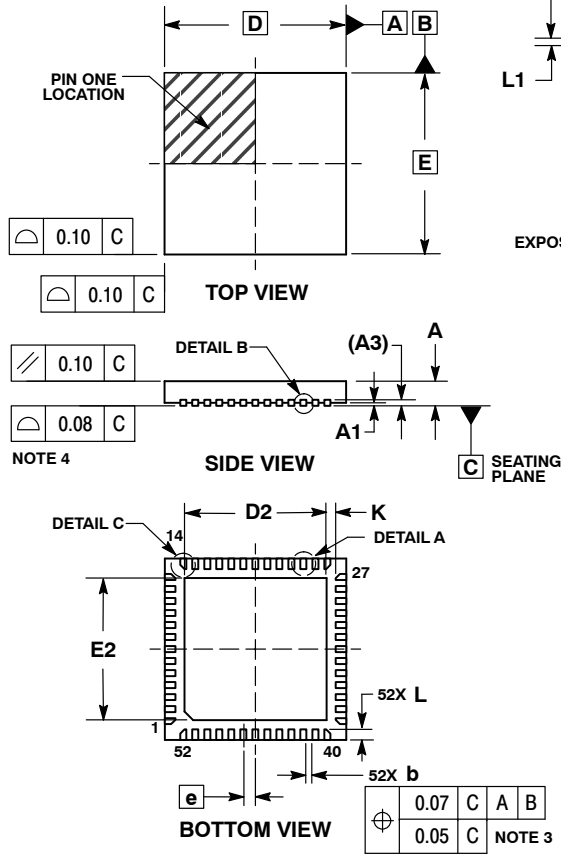

- NOTES:
1. DIMENSIONING AND TOLERANCING PER ASME Y14.5M, 1994.
  2. CONTROLLING DIMENSIONS: MILLIMETERS.
  3. DIMENSION b APPLIES TO PLATED TERMINAL AND IS MEASURED BETWEEN 0.15 AND 0.30mm FROM TERMINAL TIP
  4. COPLANARITY APPLIES TO THE EXPOSED PAD AS WELL AS THE TERMINALS.

MILLIMETERS		
DIM	MIN	MAX
A	0.80	1.00
A1	0.00	0.05
A3	0.20	REF
b	0.15	0.25
D	6.00 BSC	
D2	4.60	4.80
E	6.00 BSC	
E2	4.60	4.80
e	0.40 BSC	
K	0.30 REF	
L	0.25	0.45
L1	0.00	0.15
L2	0.15 REF	

\*For additional information on our Pb-Free strategy and soldering details, please download the ON Semiconductor Soldering and Mounting Techniques Reference Manual, SOLDERRM/D.

ON Semiconductor and are trademarks of Semiconductor Components Industries, LLC dba ON Semiconductor or its subsidiaries in the United States and/or other countries. ON Semiconductor owns the rights to a number of patents, trademarks, copyrights, trade secrets, and other intellectual property. A listing of ON Semiconductor's product/patent coverage may be accessed at [www.onsemi.com/site/pdf/Patent-Marketing.pdf](http://www.onsemi.com/site/pdf/Patent-Marketing.pdf). ON Semiconductor reserves the right to make changes without further notice to any products herein. ON Semiconductor makes no warranty, representation or guarantee regarding the suitability of its products for any particular purpose, nor does ON Semiconductor assume any liability arising out of the application or use of any product or circuit, and specifically disclaims any and all liability, including without limitation special, consequential or incidental damages. Buyer is responsible for its products and applications using ON Semiconductor products, including compliance with all laws, regulations and safety requirements or standards, regardless of any support or applications information provided by ON Semiconductor. "Typical" parameters which may be provided in ON Semiconductor data sheets and/or specifications can and do vary in different applications and actual performance may vary over time. All operating parameters, including "Typicals" must be validated for each customer application by customer's technical experts. ON Semiconductor does not convey any license under its patent rights nor the rights of others. ON Semiconductor products are not designed, intended, or authorized for use as a critical component in life support systems or any FDA Class 3 medical devices or medical devices with a same or similar classification in a foreign jurisdiction or any devices intended for implantation in the human body. Should Buyer purchase or use ON Semiconductor products for any such unintended or unauthorized application, Buyer shall indemnify and hold ON Semiconductor and its officers, employees, subsidiaries, affiliates, and distributors harmless against all claims, costs, damages, and expenses, and reasonable attorney fees arising out of, directly or indirectly, any claim of personal injury or death associated with such unintended or unauthorized use, even if such claim alleges that ON Semiconductor was negligent regarding the design or manufacture of the part. ON Semiconductor is an Equal Opportunity/Affirmative Action Employer. This literature is subject to all applicable copyright laws and is not for resale in any manner.

### PUBLICATION ORDERING INFORMATION

**LITERATURE FULFILLMENT:**  
Literature Distribution Center for ON Semiconductor  
19521 E. 32nd Pkwy, Aurora, Colorado 80011 USA  
**Phone:** 303-675-2175 or 800-344-3860 Toll Free USA/Canada  
**Fax:** 303-675-2176 or 800-344-3867 Toll Free USA/Canada  
**Email:** [orderlit@onsemi.com](mailto:orderlit@onsemi.com)

**N. American Technical Support:** 800-282-9855 Toll Free  
USA/Canada  
**Europe, Middle East and Africa Technical Support:**  
Phone: 421 33 790 2910

**ON Semiconductor Website:** [www.onsemi.com](http://www.onsemi.com)  
**Order Literature:** <http://www.onsemi.com/orderlit>

For additional information, please contact your local Sales Representative