

NL17SZ240

Inverting 3-State Buffer

The NL17SZ240 is a single inverting 3-state buffer in tiny footprint packages.

Features

- Designed for 1.65 V to 5.5 V V_{CC} Operation
- 2.7 ns t_{PD} at $V_{CC} = 5$ V (typ)
- Inputs/Outputs Overvoltage Tolerant up to 5.5 V
- I_{OFF} Supports Partial Power Down Protection
- Source/Sink 24 mA at 3.0 V
- Available in SC-88A, SC-74A, TSOP-5, SOT-553, SOT-953 and UDFN6 Packages
- Chip Complexity < 100 FETs
- NLV Prefix for Automotive and Other Applications Requiring Unique Site and Control Change Requirements; AEC-Q100 Qualified and PPAP Capable
- These Devices are Pb-Free, Halogen Free/BFR Free and are RoHS Compliant

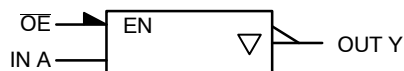

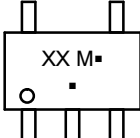

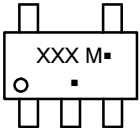

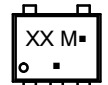

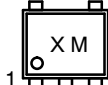





Figure 1. Logic Symbol



ON Semiconductor®

www.onsemi.com

| MARKING DIAGRAMS | | |
|--|--|---|
|  | SC-88A (SOT-353) DF SUFFIX CASE 419A |  |
|  | SC-74A DBV SUFFIX CASE 318BQ |  |
|  | SOT-553 XV5 SUFFIX CASE 463B |  |
|  | SOT-953 P5 SUFFIX CASE 527AE |  |
|  | UDFN6 1.45 x 1.0 CASE 517AQ |  |
|  | UDFN6 1.0 x 1.0 CASE 517BX |  |

XX = Specific Device Code
 M = Date Code*
 ■ = Pb-Free Package

(Note: Microdot may be in either location)

*Date Code orientation and/or position may vary depending upon manufacturing location.

ORDERING INFORMATION

See detailed ordering, marking and shipping information in the package dimensions section on page 6 of this data sheet.

NL17SZ240

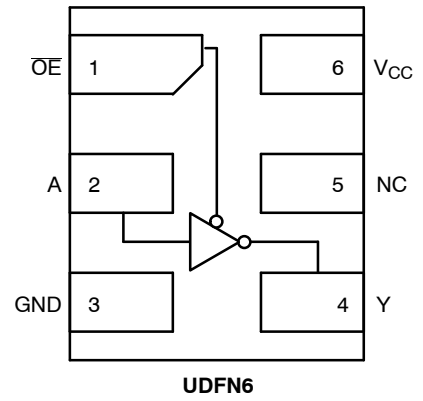
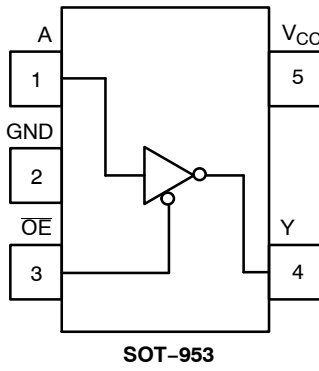
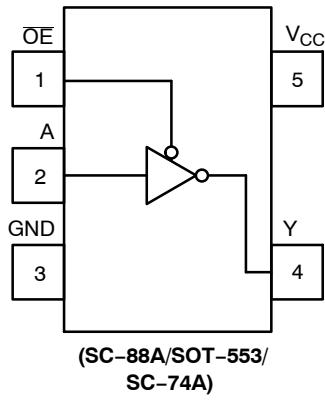

Figure 2. Pinout (Top View)

PIN ASSIGNMENT (SC-88A/SOT-553/SC-74A)

| Pin | Function |
|-----|-----------------|
| 1 | \overline{OE} |
| 2 | A |
| 3 | GND |
| 4 | Y |
| 5 | V _{CC} |

PIN ASSIGNMENT (SOT-953)

| Pin | Function |
|-----|-----------------|
| 1 | A |
| 2 | GND |
| 3 | \overline{OE} |
| 4 | Y |
| 5 | V _{CC} |

PIN ASSIGNMENT (UDFN)

| Pin | Function |
|-----|-----------------|
| 1 | \overline{OE} |
| 2 | A |
| 3 | GND |
| 4 | Y |
| 5 | NC |
| 6 | V _{CC} |

FUNCTION TABLE

| Input | | Output |
|-----------------|---|--------|
| \overline{OE} | A | Y |
| L | L | H |
| L | H | L |
| H | X | Z |

X = Don't Care

NL17SZ240

MAXIMUM RATINGS

| Symbol | Characteristics | Value | Unit | |
|-------------------------------------|--|---|---|------|
| V _{CC} | DC Supply Voltage | -0.5 to +6.5 | V | |
| V _{IN} | DC Input Voltage | -0.5 to +6.5 | V | |
| | DC Output Voltage | Active-Mode (High or Low State) Tri-State Mode (Note 1) Power-Down Mode (V _{CC} = 0 V) | -0.5 to V _{CC} + 0.5 -0.5 to +6.5 -0.5 to +6.5 | V |
| I _{IK} | DC Input Diode Current | V _{IN} < GND | -50 | mA |
| I _{OK} | DC Output Diode Current | V _{OUT} < GND | -50 | mA |
| I _{OUT} | DC Output Source/Sink Current | | ±50 | mA |
| I _{CC} or I _{GND} | DC Supply Current per Supply Pin or Ground Pin | | ±100 | mA |
| T _{STG} | Storage Temperature Range | | -65 to +150 | °C |
| T _L | Lead Temperature, 1 mm from Case for 10 secs | | 260 | °C |
| T _J | Junction Temperature Under Bias | | +150 | °C |
| θ _{JA} | Thermal Resistance (Note 2) | SC-88A | 659 | °C/W |
| | | SC-74A | 555 | |
| | | SOT-553 | 562 | |
| | | SOT-953 | 560 | |
| | | UDFN6 | 382 | |
| P _D | Power Dissipation in Still Air | SC-88A | 190 | mW |
| | | SC-74A | 225 | |
| | | SOT-553 | 222 | |
| | | SOT-953 | 223 | |
| | | UDFN6 | 327 | |
| MSL | Moisture Sensitivity | | Level 1 | - |
| F _R | Flammability Rating | Oxygen Index: 28 to 34 | UL 94 V-0 @ 0.125 in | - |
| V _{ESD} | ESD Withstand Voltage (Note 3) | Human Body Model | 2000 | V |
| | | Charged Device Model | 1000 | |
| I _{Latchup} | Latchup Performance (Note 4) | | ± 100 | mA |

Stresses exceeding those listed in the Maximum Ratings table may damage the device. If any of these limits are exceeded, device functionality should not be assumed, damage may occur and reliability may be affected.

1. Applicable to devices with outputs that may be tri-stated.
2. Measured with minimum pad spacing on an FR4 board, using 10mm-by-1inch, 2 ounce copper trace no air flow.
3. HBM tested to ANSI/ESDA/JEDEC JS-001-2017. CDM tested to EIA/JESD22-C101-F. JEDEC recommends that ESD qualification to EIA/JESD22-A115-A (Machine Model) be discontinued per JEDEC/JEP172A.
4. Tested to EIA/JESD78 Class II.

RECOMMENDED OPERATING CONDITIONS

| Symbol | Characteristics | Min | Max | Unit | |
|------------------|-----------------------------|---|------|------|-----------------|
| V _{CC} | Positive DC Supply Voltage | 1.65 | 5.5 | V | |
| V _{IN} | DC Input Voltage | 0 | 5.5 | V | |
| V _{OUT} | DC Output Voltage | Active-Mode (High or Low State) | 0 | | V _{CC} |
| | | Tri-State Mode (Note 1) | 0 | 5.5 | |
| | | Power-Down Mode (V _{CC} = 0 V) | 0 | 5.5 | |
| T _A | Operating Temperature Range | -55 | +125 | °C | |
| | Input Rise and Fall Time | V _{CC} = 1.65 V to 1.95 V | 0 | | 20 |
| | | V _{CC} = 2.3 V to 2.7 V | 0 | | 20 |
| | | V _{CC} = 3.0 V to 3.6 V | 0 | | 10 |
| | | V _{CC} = 4.5 V to 5.5 V | 0 | | 5 |

Functional operation above the stresses listed in the Recommended Operating Ranges is not implied. Extended exposure to stresses beyond the Recommended Operating Ranges limits may affect device reliability.

NL17SZ240

DC ELECTRICAL CHARACTERISTICS

| Symbol | Parameter | Condition | V _{CC} (V) | T _A = 25°C | | | -55°C ≤ T _A ≤ 125°C | | Units |
|------------------|--------------------------------|---|---------------------|-----------------------|-----------------|----------------------|--------------------------------|----------------------|-------|
| | | | | Min | Typ | Max | Min | Max | |
| V _{IH} | High-Level Input Voltage | | 1.65 to 1.95 | 0.65 V _{CC} | - | - | 0.65 V _{CC} | - | V |
| | | | 2.3 to 5.5 | 0.70 V _{CC} | - | - | 0.70 V _{CC} | - | |
| V _{IL} | Low-Level Input Voltage | | 1.65 to 1.95 | - | - | 0.35 V _{CC} | - | 0.35 V _{CC} | V |
| | | | 2.3 to 5.5 | - | - | 0.30 V _{CC} | - | 0.30 V _{CC} | |
| V _{OH} | High-Level Output Voltage | V _{IN} = V _{IH} or V _{IL} I _{OH} = -100 μA I _{OH} = -4 mA I _{OH} = -8 mA I _{OH} = -12 mA I _{OH} = -16 mA I _{OH} = -24 mA I _{OH} = -32 mA | 1.65 to 5.5 | V _{CC} - 0.1 | V _{CC} | - | V _{CC} - 0.1 | - | V |
| | | | 1.65 | 1.29 | 1.4 | - | 1.29 | - | |
| | | | 2.3 | 1.9 | 2.1 | - | 1.9 | - | |
| | | | 2.7 | 2.2 | 2.4 | - | 2.2 | - | |
| | | | 3.0 | 2.4 | 2.7 | - | 2.4 | - | |
| | | | 3.0 | 2.3 | 2.5 | - | 2.3 | - | |
| | | | 4.5 | 3.8 | 4.0 | - | 3.8 | - | |
| V _{OL} | Low-Level Output Voltage | V _{IN} = V _{IH} or V _{IL} I _{OL} = 100 μA I _{OL} = 4 mA I _{OL} = 8 mA I _{OL} = 12 mA I _{OL} = 16 mA I _{OL} = 24 mA I _{OL} = 32 mA | 1.65 to 5.5 | - | - | 0.1 | - | 0.1 | V |
| | | | 1.65 | - | 0.08 | 0.24 | - | 0.24 | |
| | | | 2.3 | - | 0.2 | 0.3 | - | 0.3 | |
| | | | 2.7 | - | 0.22 | 0.4 | - | 0.4 | |
| | | | 3.0 | - | 0.28 | 0.4 | - | 0.4 | |
| | | | 3.0 | - | 0.38 | 0.55 | - | 0.55 | |
| | | | 4.5 | - | 0.42 | 0.55 | - | 0.55 | |
| I _{IN} | Input Leakage Current | V _{IN} = 5.5 V or GND | 1.65 to 5.5 | - | - | ±0.1 | - | ±1.0 | μA |
| I _{OZ} | 3-State Output Leakage Current | V _{OUT} = 0 V to 5.5 V | 1.65 to 5.5 | - | - | ±0.5 | - | ±5.0 | μA |
| I _{OFF} | Power Off Leakage Current | V _{IN} = 5.5 V or V _{OUT} = 5.5 V | 0 | - | - | 1.0 | - | 10 | μA |
| I _{CC} | Quiescent Supply Current | V _{IN} = V _{CC} or GND | 5.5 | - | - | 1.0 | - | 10 | μA |

Product parametric performance is indicated in the Electrical Characteristics for the listed test conditions, unless otherwise noted. Product performance may not be indicated by the Electrical Characteristics if operated under different conditions.

AC ELECTRICAL CHARACTERISTICS (t_R = t_F = 3.0 ns)

| Symbol | Parameter | Condition | V _{CC} (V) | T _A = 25°C | | | -55°C ≤ T _A ≤ 125°C | | Units |
|--------------------------------------|--|--|---------------------|-----------------------|-----|-----|--------------------------------|------|-------|
| | | | | Min | Typ | Max | Min | Max | |
| t _{PLH} t _{PHL} | Propagation Delay, A to Y (Figures 3 and 4) | R _L = 1 MΩ, C _L = 15 pF | 1.65 to 1.95 | - | 6.0 | 10 | - | 10.5 | ns |
| | | R _L = 1 MΩ, C _L = 15 pF | 2.3 to 2.7 | - | 6.0 | 7.5 | - | 8.0 | |
| | | R _L = 1 MΩ, C _L = 15 pF | 3.0 to 3.6 | - | 2.5 | 5.2 | - | 5.5 | |
| | | R _L = 500 Ω, C _L = 50 pF | | - | 2.9 | 5.7 | - | 6.0 | |
| | | R _L = 1 MΩ, C _L = 15 pF | 4.5 to 5.5 | - | 2.0 | 4.5 | - | 4.8 | |
| | | R _L = 500 Ω, C _L = 50 pF | | - | 2.3 | 5.0 | - | 5.3 | |
| t _{PZH} t _{PZL} | Output Enable Time, OE to Y (Figures 3 and 4) | | 1.65 to 1.95 | - | 7.6 | 9.5 | - | 10 | ns |
| | | | 2.3 to 2.7 | - | 3.6 | 8.5 | - | 9.0 | |
| | | | 3.0 to 3.6 | - | 2.8 | 6.2 | - | 6.5 | |
| | | | 4.5 to 5.5 | - | 2.0 | 5.5 | - | 5.8 | |
| t _{PHZ} t _{PLZ} | Output Disable Time, OE to Y (Figures 3 and 4) | | 1.65 to 1.95 | - | 5.0 | 10 | - | 10.5 | ns |
| | | | 2.3 to 2.7 | - | 3.3 | 8.0 | - | 8.5 | |
| | | | 3.0 to 3.6 | - | 2.7 | 5.7 | - | 6.0 | |
| | | | 4.5 to 5.5 | - | 2.6 | 4.7 | - | 5.0 | |

CAPACITIVE CHARACTERISTICS ($t_R = t_F = 3.0$ ns)

| Symbol | Parameter | Condition | Typical | Units |
|-----------|--|--|---------|-------|
| C_{IN} | Input Capacitance | $V_{CC} = 5.5$ V, $V_{IN} = 0$ V or V_{CC} | 2.5 | pF |
| C_{OUT} | Output Capacitance | $V_{CC} = 5.5$ V, $V_{IN} = 0$ V or V_{CC} | 2.5 | pF |
| C_{PD} | Power Dissipation Capacitance (Note 5) | 10 MHz, $V_{CC} = 3.3$ V, $V_{IN} = 0$ V or V_{CC} | 9 | pF |
| | | 10 MHz, $V_{CC} = 5.5$ V, $V_{IN} = 0$ V or V_{CC} | 11 | |

5. C_{PD} is defined as the value of the internal equivalent capacitance which is calculated from the operating current consumption without load. Average operating current can be obtained by the equation: $I_{CC(OPR)} = C_{PD} \cdot V_{CC} \cdot f_{in} + I_{CC}$. C_{PD} is used to determine the no-load dynamic power consumption; $P_D = C_{PD} \cdot V_{CC}^2 \cdot f_{in} + I_{CC} \cdot V_{CC}$.

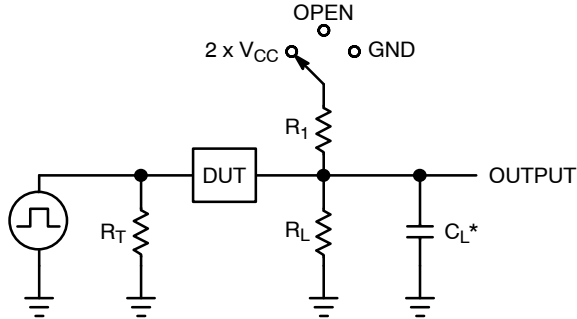

C_L includes probe and jig capacitance
 R_T is Z_{OUT} of pulse generator (typically 50 Ω)
 $f = 1$ MHz

Figure 3. Test Circuit

| Test | Switch Position | C_L , pF | R_L , Ω | R_1 , Ω |
|---------------------|-------------------|------------------------------|------------------|------------------|
| t_{PLH} / t_{PHL} | Open | See AC Characteristics Table | | |
| t_{PLZ} / t_{PZL} | $2 \times V_{CC}$ | 50 | 500 | 500 |
| t_{PHZ} / t_{PZH} | GND | 50 | 500 | 500 |

X = Don't Care

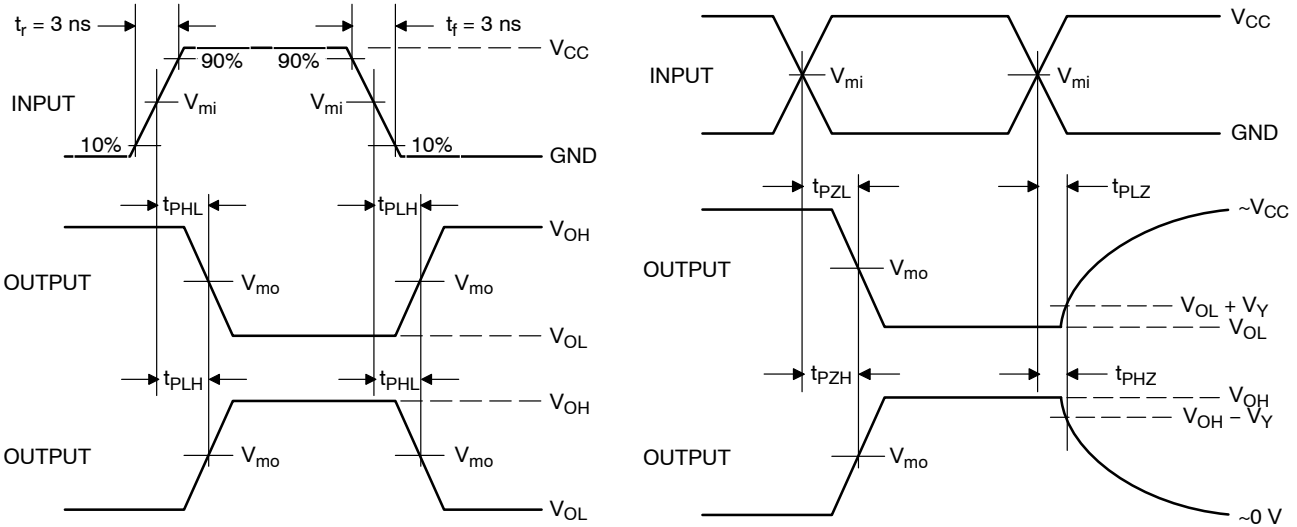

Figure 4. Switching Waveforms

| V_{CC} , V | V_{mi} , V | V_{mo} , V | | V_Y , V |
|--------------|--------------|-----------------------|--------------------------------------|-----------|
| | | t_{PLH}, t_{PHL} | $t_{PZL}, t_{PLZ}, t_{PZH}, t_{PHZ}$ | |
| 1.65 to 1.95 | $V_{CC}/2$ | $(V_{OH} - V_{OL})/2$ | $V_{CC}/2$ | 0.15 |
| 2.3 to 2.7 | $V_{CC}/2$ | $(V_{OH} - V_{OL})/2$ | $V_{CC}/2$ | 0.15 |
| 3.0 to 3.6 | $V_{CC}/2$ | $(V_{OH} - V_{OL})/2$ | $V_{CC}/2$ | 0.3 |
| 4.5 to 5.5 | $V_{CC}/2$ | $(V_{OH} - V_{OL})/2$ | $V_{CC}/2$ | 0.3 |

NL17SZ240

DEVICE ORDERING INFORMATION

| Device | Packages | Marking | Pin 1 Orientation (See below) | Shipping [†] |
|--------------------------------------|---------------------------|---------|----------------------------------|-----------------------|
| NL17SZ240DFT2G | SC-88A | U7 | Q4 | 3000 / Tape & Reel |
| NLV17SZ240DFT1G* (In Development) | SC-88A | U7 | Q2 | 3000 / Tape & Reel |
| NLV17SZ240DFT2G* (In Development) | SC-88A | U7 | Q4 | 3000 / Tape & Reel |
| NL17SZ240DBVT1G (In Development) | SC-74A | TBD | TBD | 3000 / Tape & Reel |
| NL17SZ240XV5T2G (In Development) | SOT-553 | TBD | TBD | 3000 / Tape & Reel |
| NL17SZ240P5T5G (In Development) | SOT-953 | TBD | TBD | 4000 / Tape & Reel |
| NL17SZ240MU1TCG (In Development) | UDFN6, 1.45 x 1.0 x 0.35P | TBD | TBD | 3000 / Tape & Reel |
| NL17SZ240MU3TCG (In Development) | UDFN6, 1.0 x 1.0 x 0.35P | TBD | TBD | 3000 / Tape & Reel |

[†]For information on tape and reel specifications, including part orientation and tape sizes, please refer to our Tape and Reel Packaging Specifications Brochure, BRD8011/D.

*NLV Prefix for Automotive and Other Applications Requiring Unique Site and Control Change Requirements; AEC-Q100 Qualified and PPAP Capable.

Pin 1 Orientation in Tape and Reel

Direction of Feed

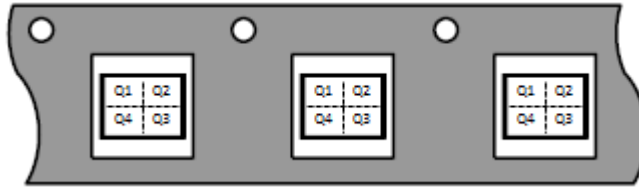

NL17SZ240

PACKAGE DIMENSIONS

SC-88A (SC-70-5/SOT-353)
CASE 419A-02
ISSUE L

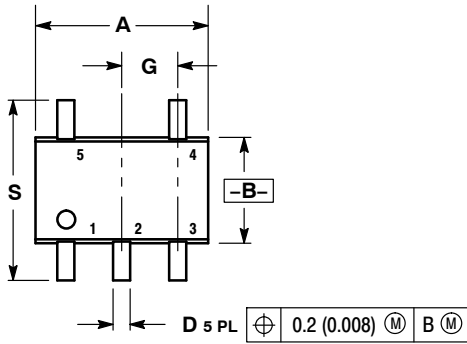

- NOTES:
1. DIMENSIONING AND TOLERANCING PER ANSI Y14.5M, 1982.
 2. CONTROLLING DIMENSION: INCH.
 3. 419A-01 OBSOLETE. NEW STANDARD 419A-02.
 4. DIMENSIONS A AND B DO NOT INCLUDE MOLD FLASH, PROTRUSIONS, OR GATE BURRS.

| DIM | INCHES | | MILLIMETERS | |
|-----|-----------|-------|-------------|------|
| | MIN | MAX | MIN | MAX |
| A | 0.071 | 0.087 | 1.80 | 2.20 |
| B | 0.045 | 0.053 | 1.15 | 1.35 |
| C | 0.031 | 0.043 | 0.80 | 1.10 |
| D | 0.004 | 0.012 | 0.10 | 0.30 |
| G | 0.026 BSC | | 0.65 BSC | |
| H | --- | 0.004 | --- | 0.10 |
| J | 0.004 | 0.010 | 0.10 | 0.25 |
| K | 0.004 | 0.012 | 0.10 | 0.30 |
| N | 0.008 REF | | 0.20 REF | |
| S | 0.079 | 0.087 | 2.00 | 2.20 |

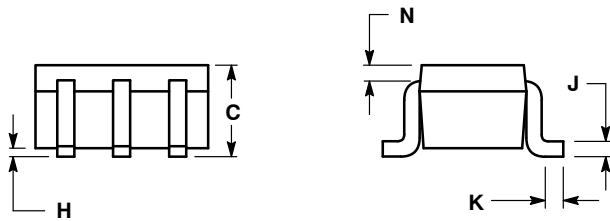

SOLDER FOOTPRINT*

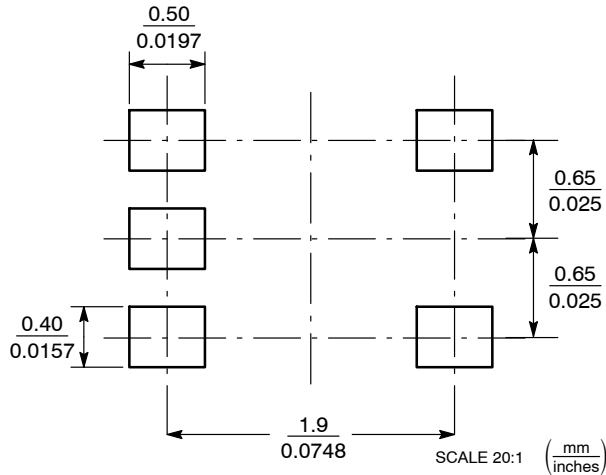

*For additional information on our Pb-Free strategy and soldering details, please download the ON Semiconductor Soldering and Mounting Techniques Reference Manual, SOLDERRM/D.

NL17SZ240

PACKAGE DIMENSIONS

SC-74A CASE 318BQ ISSUE B

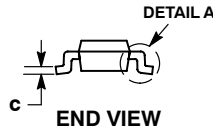
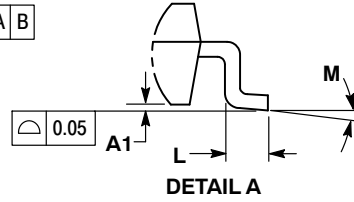
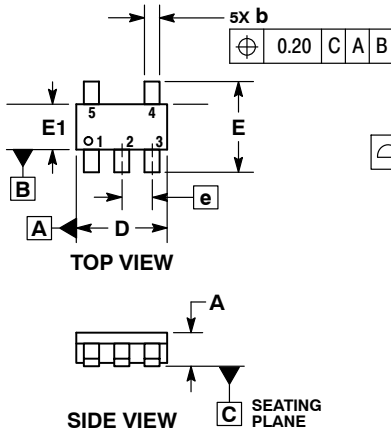

NOTES:

1. DIMENSIONING AND TOLERANCING PER ASME Y14.5M, 1994.
2. CONTROLLING DIMENSION: MILLIMETERS.
3. MAXIMUM LEAD THICKNESS INCLUDES LEAD FINISH THICKNESS. MINIMUM LEAD THICKNESS IS THE MINIMUM THICKNESS OF BASE MATERIAL.
4. DIMENSIONS A AND B DO NOT INCLUDE MOLD FLASH, PROTRUSIONS, OR GATE BURRS. MOLD FLASH, PROTRUSIONS, OR GATE BURRS SHALL NOT EXCEED 0.15 PER SIDE.

| DIM | MILLIMETERS | |
|-----|-------------|------|
| | MIN | MAX |
| A | 0.90 | 1.10 |
| A1 | 0.01 | 0.10 |
| b | 0.25 | 0.50 |
| c | 0.10 | 0.26 |
| D | 2.85 | 3.15 |
| E | 2.50 | 3.00 |
| E1 | 1.35 | 1.65 |
| e | 0.95 BSC | |
| L | 0.20 | 0.60 |
| M | 0° 10° | |

RECOMMENDED SOLDERING FOOTPRINT*

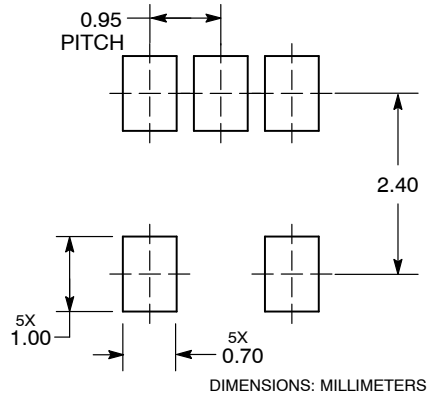

DIMENSIONS: MILLIMETERS

*For additional information on our Pb-Free strategy and soldering details, please download the ON Semiconductor Soldering and Mounting Techniques Reference Manual, SOLDERRM/D.

NL17SZ240

PACKAGE DIMENSIONS

SOT-553, 5 LEAD CASE 463B ISSUE C

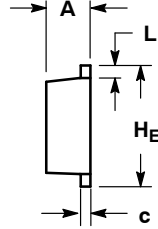
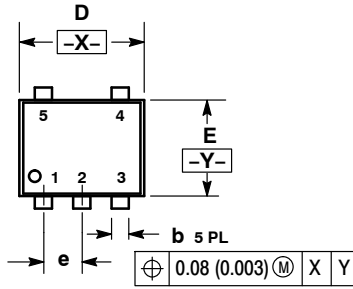

NOTES:

1. DIMENSIONING AND TOLERANCING PER ANSI Y14.5M, 1982.
2. CONTROLLING DIMENSION: MILLIMETERS
3. MAXIMUM LEAD THICKNESS INCLUDES LEAD FINISH THICKNESS. MINIMUM LEAD THICKNESS IS THE MINIMUM THICKNESS OF BASE MATERIAL.

| DIM | MILLIMETERS | | | INCHES | | |
|-----|-------------|------|------|-----------|-------|-------|
| | MIN | NOM | MAX | MIN | NOM | MAX |
| A | 0.50 | 0.55 | 0.60 | 0.020 | 0.022 | 0.024 |
| b | 0.17 | 0.22 | 0.27 | 0.007 | 0.009 | 0.011 |
| c | 0.08 | 0.13 | 0.18 | 0.003 | 0.005 | 0.007 |
| D | 1.55 | 1.60 | 1.65 | 0.061 | 0.063 | 0.065 |
| E | 1.15 | 1.20 | 1.25 | 0.045 | 0.047 | 0.049 |
| e | 0.50 BSC | | | 0.020 BSC | | |
| L | 0.10 | 0.20 | 0.30 | 0.004 | 0.008 | 0.012 |
| HE | 1.55 | 1.60 | 1.65 | 0.061 | 0.063 | 0.065 |

SOLDERING FOOTPRINT*

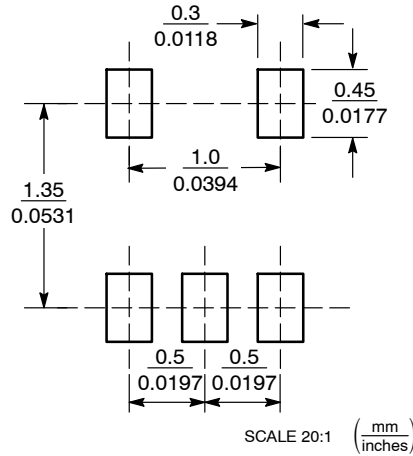

*For additional information on our Pb-Free strategy and soldering details, please download the ON Semiconductor Soldering and Mounting Techniques Reference Manual, SOLDERRM/D.

NL17SZ240

PACKAGE DIMENSIONS

SOT-953
CASE 527AE
ISSUE E

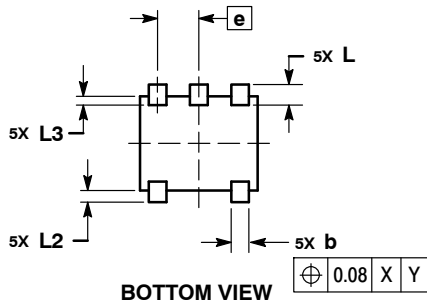
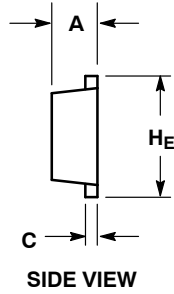
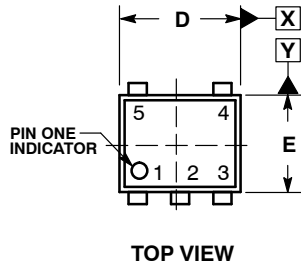

NOTES:

1. DIMENSIONING AND TOLERANCING PER ASME Y14.5M, 1994.
2. CONTROLLING DIMENSION: MILLIMETERS
3. MAXIMUM LEAD THICKNESS INCLUDES LEAD FINISH. MINIMUM LEAD THICKNESS IS THE MINIMUM THICKNESS OF THE BASE MATERIAL.
4. DIMENSIONS D AND E DO NOT INCLUDE MOLD FLASH, PROTRUSIONS, OR GATE BURRS.

| MILLIMETERS | | | |
|----------------|-----------|------|------|
| DIM | MIN | NOM | MAX |
| A | 0.34 | 0.37 | 0.40 |
| b | 0.10 | 0.15 | 0.20 |
| C | 0.07 | 0.12 | 0.17 |
| D | 0.95 | 1.00 | 1.05 |
| E | 0.75 | 0.80 | 0.85 |
| e | 0.35 BSC | | |
| H _E | 0.95 | 1.00 | 1.05 |
| L | 0.175 REF | | |
| L2 | 0.05 | 0.10 | 0.15 |
| L3 | --- | --- | 0.15 |

SOLDERING FOOTPRINT*

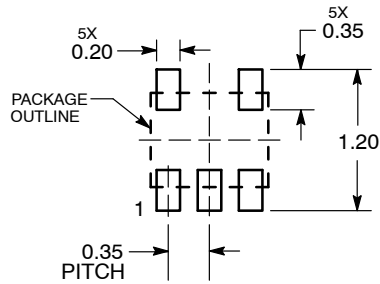

DIMENSIONS: MILLIMETERS

*For additional information on our Pb-Free strategy and soldering details, please download the ON Semiconductor Soldering and Mounting Techniques Reference Manual, SOLDETRM/D.

NL17SZ240

PACKAGE DIMENSIONS

UDFN6, 1.45x1.0, 0.5P
CASE 517AQ
ISSUE O

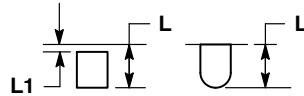
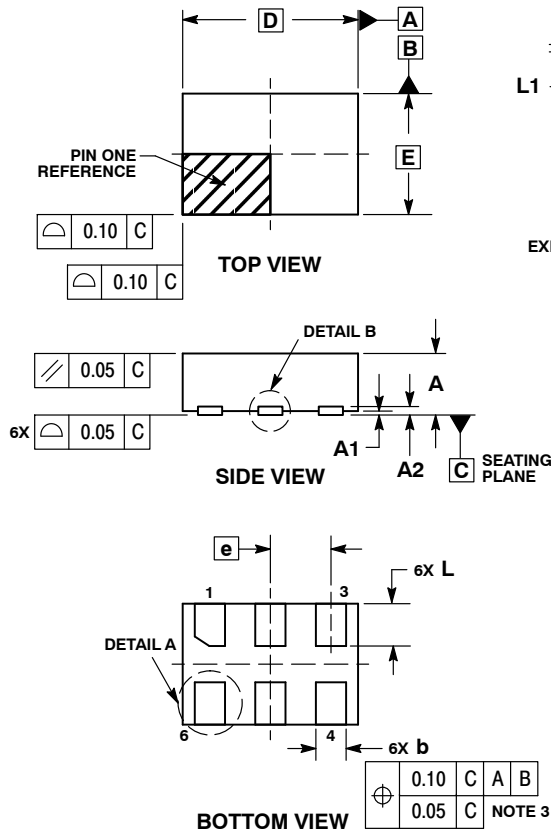

DETAIL A
OPTIONAL
CONSTRUCTIONS

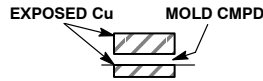

DETAIL B
OPTIONAL
CONSTRUCTIONS

NOTES:

1. DIMENSIONING AND TOLERANCING PER ASME Y14.5M, 1994.
2. CONTROLLING DIMENSION: MILLIMETERS.
3. DIMENSION b APPLIES TO PLATED TERMINAL AND IS MEASURED BETWEEN 0.15 AND 0.30 mm FROM THE TERMINAL TIP.

| MILLIMETERS | | |
|-------------|------|------|
| DIM | MIN | MAX |
| A | 0.45 | 0.55 |
| A1 | 0.00 | 0.05 |
| A2 | 0.07 | REF |
| b | 0.20 | 0.30 |
| D | 1.45 | BSC |
| E | 1.00 | BSC |
| e | 0.50 | BSC |
| L | 0.30 | 0.40 |
| L1 | --- | 0.15 |

MOUNTING FOOTPRINT

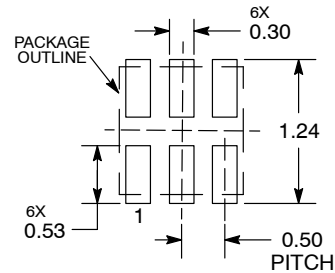

DIMENSIONS: MILLIMETERS

*For additional information on our Pb-Free strategy and soldering details, please download the ON Semiconductor Soldering and Mounting Techniques Reference Manual, SOLDERRM/D.

NL17SZ240

PACKAGE DIMENSIONS

UDFN6, 1x1, 0.35P
CASE 517BX
ISSUE O

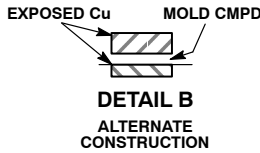
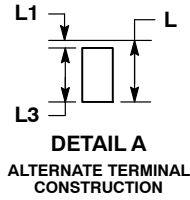
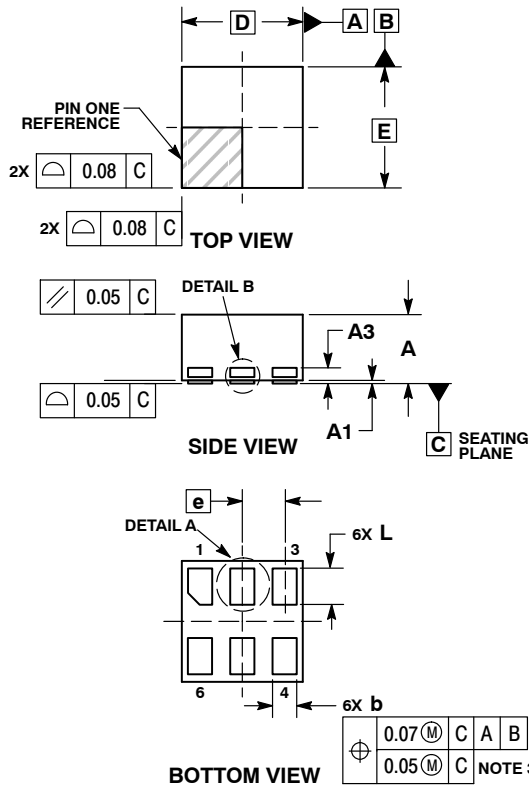

NOTES:

1. DIMENSIONING AND TOLERANCING PER ASME Y14.5M, 1994.
2. CONTROLLING DIMENSION: MILLIMETERS.
3. DIMENSION b APPLIES TO PLATED TERMINAL AND IS MEASURED BETWEEN 0.15 AND 0.20 MM FROM TERMINAL TIP.
4. PACKAGE DIMENSIONS EXCLUSIVE OF BURRS AND MOLD FLASH.

| DIM | MILLIMETERS | |
|-----|-------------|------|
| | MIN | MAX |
| A | 0.50 | 0.65 |
| A1 | 0.00 | 0.05 |
| A3 | 0.13 REF | |
| b | 0.17 | 0.23 |
| D | 1.00 BSC | |
| E | 1.00 BSC | |
| e | 0.35 | |
| L | 0.20 | 0.40 |
| L1 | --- | 0.15 |
| L3 | 0.26 | 0.33 |

RECOMMENDED SOLDERING FOOTPRINT*

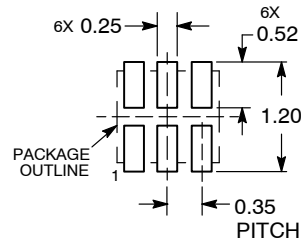

DIMENSION: MILLIMETERS

*For additional information on our Pb-Free strategy and soldering details, please download the ON Semiconductor Soldering and Mounting Techniques Reference Manual, SOLDERRM/D.

ON Semiconductor and are trademarks of Semiconductor Components Industries, LLC dba ON Semiconductor or its subsidiaries in the United States and/or other countries. ON Semiconductor owns the rights to a number of patents, trademarks, copyrights, trade secrets, and other intellectual property. A listing of ON Semiconductor's product/patent coverage may be accessed at www.onsemi.com/site/pdf/Patent-Marketing.pdf. ON Semiconductor reserves the right to make changes without further notice to any products herein. ON Semiconductor makes no warranty, representation or guarantee regarding the suitability of its products for any particular purpose, nor does ON Semiconductor assume any liability arising out of the application or use of any product or circuit, and specifically disclaims any and all liability, including without limitation special, consequential or incidental damages. Buyer is responsible for its products and applications using ON Semiconductor products, including compliance with all laws, regulations and safety requirements or standards, regardless of any support or applications information provided by ON Semiconductor. "Typical" parameters which may be provided in ON Semiconductor data sheets and/or specifications can and do vary in different applications and actual performance may vary over time. All operating parameters, including "Typicals" must be validated for each customer application by customer's technical experts. ON Semiconductor does not convey any license under its patent rights nor the rights of others. ON Semiconductor products are not designed, intended, or authorized for use as a critical component in life support systems or any FDA Class 3 medical devices or medical devices with a same or similar classification in a foreign jurisdiction or any devices intended for implantation in the human body. Should Buyer purchase or use ON Semiconductor products for any such unintended or unauthorized application, Buyer shall indemnify and hold ON Semiconductor and its officers, employees, subsidiaries, affiliates, and distributors harmless against all claims, costs, damages, and expenses, and reasonable attorney fees arising out of, directly or indirectly, any claim of personal injury or death associated with such unintended or unauthorized use, even if such claim alleges that ON Semiconductor was negligent regarding the design or manufacture of the part. ON Semiconductor is an Equal Opportunity/Affirmative Action Employer. This literature is subject to all applicable copyright laws and is not for resale in any manner.

PUBLICATION ORDERING INFORMATION

LITERATURE FULFILLMENT:

Literature Distribution Center for ON Semiconductor
19521 E. 32nd Pkwy, Aurora, Colorado 80011 USA
Phone: 303-675-2175 or 800-344-3860 Toll Free USA/Canada
Fax: 303-675-2176 or 800-344-3867 Toll Free USA/Canada
Email: orderlit@onsemi.com

N. American Technical Support: 800-282-9855 Toll Free
USA/Canada
Europe, Middle East and Africa Technical Support:
Phone: 421 33 790 2910

ON Semiconductor Website: www.onsemi.com

Order Literature: <http://www.onsemi.com/orderlit>

For additional information, please contact your local Sales Representative