

NL3S588

USB 2.0-Capable Ultra-Low THD DPDT Switch

The NL3S588 is a single supply, bidirectional, double-pole/double-throw (DPDT) switch suitable for both hi-fidelity audio and high-speed data applications.

The NL3S588 features ultra-low distortion, high OFF-Isolation analog switches that can pass analog signals that are positive and negative with respect to ground. It is targeted at consumer and professional DC-coupled GND-referenced audio switching applications such as computer sound cards and home theater products.

The NL3S588 may also be used in high-speed differential data routing applications. Both channels are USB 2.0-compliant.

Features

- DPDT Switch
- 3.3 V Single Supply Operation
- Available in 1.4 mm x 1.8 mm UQFN10
- This Device is Pb-Free, Halogen Free/BFR Free and RoHS Compliant

Audio Capabilities

- 2 V_{RMS} Signal Switching
- -116 dB THD+N into 20 k Ω Load at 2 V_{RMS}
- -112 dB THD+N into 32 Ω Load at 0.707 V_{RMS}
- Signal to Noise Ratio: > 125 dBV
- ± 0.004 dB Insertion Loss at 1 kHz, 20 k Ω Load
- ± 0.0008 dB Gain Variation 20 Hz to 20 kHz
- 112 dB Signal Muting into 20 k Ω Load
- 131 dB PSRR 20 Hz to 20 kHz

High-Speed Data Capabilities

- Input Signal Range: 0 V to V_{DD}
- C_{ON} : 8.9 pF (Typ)
- Data Rate: USB 2.0-Compliant – up to 480 Mbps
- Bandwidth: 580 MHz

Applications

- Hi-Fi Audio Switching
- USB 2.0 High-Speed Data Switching
- USB 3.x Type C Switching



ON Semiconductor®

www.onsemi.com

MARKING DIAGRAM

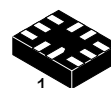

UQFN10
MU SUFFIX
CASE 488AT

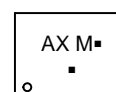

AX = Device Code
M = Date Code
▪ = Pb-Free Device

(Note: Microdot may be in either location)

PIN ASSIGNMENT

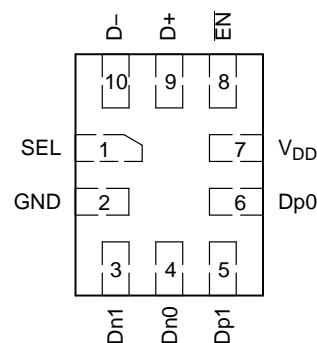

(Top View)

ORDERING INFORMATION

Device	Package	Shipping [†]
NL3S588MUTBG	UQFN10 (Pb-Free)	3000 / Tape & Reel

[†]For information on tape and reel specifications, including part orientation and tape sizes, please refer to our Tape and Reel Packaging Specification Brochure, BRD8011/D.

NL3S588

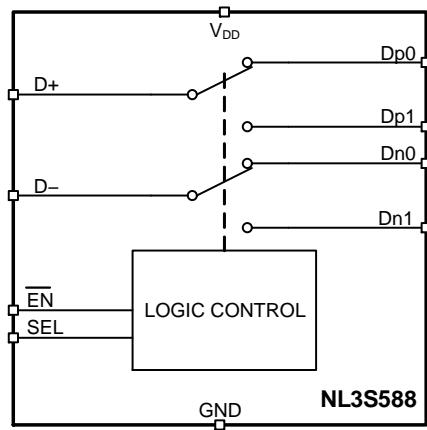

Figure 1. Block Diagram

FUNCTION TABLE

INPUTS		Operating Mode
EN	SEL	
0	0	Dp0 connected to D+ / Dn0 connected to D-
0	1	Dp1 connected to D+ / Dn1 connected to D-
1	X	Shutdown (I/Os Disconnected)

NOTE: EN Logic "0" ≤ 0.5 V, Logic "1" ≥ 1.4 V or float.
 SEL Logic "0" ≤ 0.5 V, Logic "1" ≥ 1.4 V.
 X = Don't Care

PIN DESCRIPTIONS

PIN NAME	PIN	DESCRIPTION
SEL	1	Channel Select
GND	2	Ground
Dn1	3	Normally-Open I/O
Dp1	5	
Dn0	4	Normally-Closed I/O
Dp0	6	
V _{DD}	7	System power supply pin (+3 V to +3.6 V)
EN	8	Signal mute control pin
D+	9	Common I/O
D-	10	

MAXIMUM RATINGS

Symbol	Rating	Value	Unit
V _{DD}	Positive 3 V DC Supply Voltage	-0.5 to +4.1	V
V _{IS}	Analog Input/Output Voltage (D+, D-, Dpx, Dnx)	-3.1 to V _{DD} + 0.5	V
V _{IN}	Digital Input Voltage (EN, SEL)	-0.5 to V _{DD} + 0.5	V
I _{IO}	Switch Continuous Current (D+, D-, Dpx, Dnx)	±300	mA
I _{IO_PK}	Switch Peak Current (D+, D-, Dpx, Dnx) (Pulsed 1 ms, 10% Duty Cycle, Max).	±500	mA
P _D	Power Dissipation in Still Air	800	mW
T _s	Storage Temperature	-65 to +150	°C
T _L	Lead Temperature, 1 mm from Case for 10 seconds	260	°C
T _J	Junction Bias Under Bias	150	°C
θ _{JA}	Thermal Resistance	80	°C/W
T _s	Storage Temperature	-65 to +150	°C
MSL	Moisture Sensitivity	Level 1	
F _R	Flammability Rating Oxygen Index: 30% – 35%	UL94-V0 (0.125 in)	°C
ESD	ESD Protection Human Body Model Machine Model	3000 200	V
I _L	Latch-up Current, Above V _{CC} and below GND at 125°C (Note 1)	±300	mA

Stresses exceeding those listed in the Maximum Ratings table may damage the device. If any of these limits are exceeded, device functionality should not be assumed, damage may occur and reliability may be affected.

1. Tested to EIA/JESD78.

RECOMMENDED OPERATING CONDITIONS

Symbol	Parameter	Min	Max	Unit
V _{DD}	Positive DC Supply Voltage	3.0	3.6	V
V _S	Switch Input / Output Voltage (D+, D-, Dpx, Dnx)	-2.9	V _{DD}	V
V _{IN}	Digital Select Input Voltage (EN, SEL)	GND	V _{DD}	V
T _A	Operating Temperature Range	-40	+85	°C

DC ELECTRICAL CHARACTERISTICS (Voltages referenced to GND): V_{DD} = +3.0 V to +3.6 V, GND = 0 V, V_S = 2 V_{RMS}, R_{LOAD} = 20 kΩ, f = 1 kHz, V_{SELH} = V_{ENH} = 1.4 V, V_{SELL} = V_{ENL} = 0.5 V, (Note 2), Unless otherwise specified.

Parameter	Test Conditions	Supply (V)	Temp (°C)	Min (Notes 3, 4)	Typ	Max (Notes 3, 4)	Units
-----------	-----------------	------------	-----------	------------------	-----	------------------	-------

ANALOG SWITCH CHARACTERISTICS

Analog Signal Range, V _{ANALOG}		3.3	Full	-	2	-	V _{RMS}
ON-Resistance, r _{ON}	I _{D+} or I _{D-} = 80mA, V _{Dpx} or V _{Dnx} = -2.828 V to +2.828 V (See Figure 5)	3.3	25	-	2.1	-	Ω
			Full	-	2.5	-	
r _{ON} Matching Between Channels, Δr _{ON}	I _{D+} or I _{D-} = 80mA, V _{Dpx} or V _{Dnx} = Voltage at max r _{ON} over -2.828 V to +2.828 V (Note 7)	3.3	25	-	0.046	-	Ω
			Full	-	0.23	-	
r _{ON} Flatness, r _{FLAT(ON)}	I _{D+} or I _{D-} = 80mA, V _{Dpx} or V _{Dnx} = -2.828 V, 0V, +2.828 V (Note 5)	3.3	25	-	0.047	0.05	Ω
			Full	-	0.092	-	

- V_{IN} = input voltage to perform proper function.
- The algebraic convention, whereby the most negative value is a minimum and the most positive a maximum, is used in this data sheet.
- Parameters with MIN and/or MAX limits are 100% tested at +25°C, unless otherwise specified. Temperature limits established by characterization and are not production tested.
- Flatness is defined as the difference between maximum and minimum value of ON-resistance at the specified analog signal voltage points.
- Limits established by characterization and are not production tested.
- r_{ON} matching between channels is calculated by subtracting the channel with the highest max r_{ON} value from the channel with lowest max r_{ON} value.
- Crosstalk is inversely proportional to source impedance.

NL3S588

DC ELECTRICAL CHARACTERISTICS (Voltages referenced to GND): $V_{DD} = +3.0\text{ V}$ to $+3.6\text{ V}$, $GND = 0\text{ V}$, $V_S = 2\text{ V}_{RMS}$, $R_{LOAD} = 20\text{ k}\Omega$, $f = 1\text{ kHz}$, $V_{SELH} = V_{ENH} = 1.4\text{ V}$, $V_{SELL} = V_{ENL} = 0.5\text{ V}$, (Note 2), Unless otherwise specified.

Parameter	Test Conditions	Supply (V)	Temp (°C)	Min (Notes 3, 4)	Typ	Max (Notes 3, 4)	Units
-----------	-----------------	------------	-----------	------------------	-----	------------------	-------

ANALOG SWITCH CHARACTERISTICS

D+, D-, Dpx, Dnx Pull-down Resistance	V_{Dpx} or $V_{Dnx} = -2.83\text{ V}$, 2.83 V , V_{D+} or $V_{D-} = -2.83\text{ V}$, 2.83 V , $V_{EN} = 3.6\text{ V}$, measure current, calculate resistance.	3.6	25	225	300	375	k Ω
			Full	-	345	-	

DYNAMIC CHARACTERISTICS

THD+N	$V_S = 2\text{ V}_{RMS}$, $f = 1\text{ kHz}$, A-weighted filter, $R_{LOAD} = 20\text{ k}\Omega$	3.3	25	-	< -116	-	dB
	$V_S = 1.9\text{ V}_{RMS}$, $f = 1\text{ kHz}$, A-weighted filter, $R_{LOAD} = 20\text{ k}\Omega$		25	-	< -116	-	
	$V_S = 1.8\text{ V}_{RMS}$, $f = 1\text{ kHz}$, A-weighted filter, $R_{LOAD} = 20\text{ k}\Omega$		25	-	< -116	-	
	$V_S = 0.707\text{ V}_{RMS}$, $f = 1\text{ kHz}$, A-weighted filter, $R_{LOAD} = 32\text{ }\Omega$		25	-	< -112	-	
SNR	$f = 20\text{ Hz}$ to 20 kHz , A-weighted filter, inputs grounded, $R_{LOAD} = 20\text{ k}\Omega$ or $32\text{ }\Omega$	3.3	25	-	> 125	-	dBV
Insertion Loss, G_{ON}	$f = 1\text{ kHz}$, $R_{LOAD} = 20\text{ k}\Omega$	3.3	25	-	± 0.004	-	dB
Gain vs Frequency, G_f	$f = 20\text{ Hz}$ to 20 kHz , $R_{LOAD} = 20\text{ k}\Omega$, reference to G_{ON} at 1 kHz	3.3	25	-	± 0.0008	-	dB
Stereo Channel Imbalance $Dp0$ and $Dn0$, $Dp1$ and $Dn1$	$f = 20\text{ Hz}$ to 20 kHz , $R_{LOAD} = 20\text{ k}\Omega$	3.3	25	-	± 0.0001	-	dB
OFF-Isolation (Disabling)	$f = 20\text{ Hz}$ to 22 kHz , $D+ = D- = 2\text{ V}_{RMS}$, $R_{LOAD} = 20\text{ k}\Omega$, $SEL = "X"$	3.3	25	-	112	-	dB
	$f = 20\text{ Hz}$ to 22 kHz , V_{D+} or $V_{D-} = 0.7\text{ V}_{RMS}$, $R_{LOAD} = 32\text{ }\Omega$		25	-	129	-	
Crosstalk (Channel-to-Channel)	$R_L = 20\text{ k}\Omega$, $f = 20\text{ Hz}$ to 20 kHz , $V_S = 2\text{ V}_{RMS}$, signal source impedance = $20\text{ }\Omega$, (Note 8)	3.3	25	-	102	-	dB
	$R_L = 32\text{ }\Omega$, $f = 20\text{ Hz}$ to 20 kHz , $V_S = 0.7\text{ V}_{RMS}$, signal source impedance = $20\text{ }\Omega$, (Note 8)		25	-	129	-	
PSRR	$f = 1\text{ kHz}$, $V_S = 100\text{ mV}_{RMS}$, inputs grounded	3.3	25	-	131	-	dB
	$f = 20\text{ kHz}$, $V_S = 100\text{ mV}_{RMS}$, inputs grounded		25	-	133	-	
Bandwidth, -3 dB	$R_{LOAD} = 50\text{ }\Omega$	3.3	25	-	580	-	MHz
ON to Disable Time, $T_{TRANS-OM}$		3.3	25	-	250	-	ns
Disable to ON Time, $T_{TRANS-MO}$	$V_{IS} = 1.5\text{ V}$	3.3	25	-	1680	-	μs
Turn-ON Time, t_{ON}	V_{Dpx} or $V_{Dnx} = 1.5\text{ V}$, $V_{EN} = 0\text{ V}$, $R_L = 32\text{ }\Omega$ (See Figure 2)	3.3	25	-	14	-	μs
Turn-OFF Time, t_{OFF}	V_{Dpx} or $V_{Dnx} = 1.5\text{ V}$, $V_{EN} = 0\text{ V}$, $R_L = 32\text{ }\Omega$ (See Figure 2)	3.3	25	-	95	-	ns

- V_{IN} = input voltage to perform proper function.
- The algebraic convention, whereby the most negative value is a minimum and the most positive a maximum, is used in this data sheet.
- Parameters with MIN and/or MAX limits are 100% tested at $+25^\circ\text{C}$, unless otherwise specified. Temperature limits established by characterization and are not production tested.
- Flatness is defined as the difference between maximum and minimum value of ON-resistance at the specified analog signal voltage points.
- Limits established by characterization and are not production tested.
- r_{ON} matching between channels is calculated by subtracting the channel with the highest max r_{ON} value from the channel with lowest max r_{ON} value.
- Crosstalk is inversely proportional to source impedance.

NL3S588

DC ELECTRICAL CHARACTERISTICS (Voltages referenced to GND): $V_{DD} = +3.0\text{ V to }+3.6\text{ V}$, $GND = 0\text{ V}$, $V_S = 2\text{ V}_{RMS}$, $R_{LOAD} = 20\text{ k}\Omega$, $f = 1\text{ kHz}$, $V_{SELH} = V_{ENH} = 1.4\text{ V}$, $V_{SELL} = V_{ENL} = 0.5\text{ V}$, (Note 2), Unless otherwise specified.

Parameter	Test Conditions	Supply (V)	Temp (°C)	Min (Notes 3, 4)	Typ	Max (Notes 3, 4)	Units
DYNAMIC CHARACTERISTICS							
Break-Before-Make Time Delay, t_D	V_{Dpx} or $V_{Dnx} = 1.5\text{ V}$, $V_{EN} = 0\text{ V}$, $R_L = 32\ \Omega$ (See Figure 3)	3.6	25	–	10	–	μs
OFF-Isolation	$R_L = 50\ \Omega$, $f = 1\text{ MHz}$, V_{D+} or $V_{D-} = 1\text{ V}_{RMS}$ (See Figure 4)	3.3	25	–	70	–	dB
Crosstalk (Channel-to-Channel)	$R_L = 50\ \Omega$, $f = 1\text{ MHz}$, V_{D+} or $V_{D-} = 1\text{ V}_{RMS}$ (See Figure 4)	3.3	25	–	89	–	dB
Dpx, Dnx OFF Capacitance, C_{OFF}	$f = 1\text{ MHz}$, V_{Dpx} or $V_{Dnx} = V_{D+}$ or $V_{D-} = 0\text{ V}$ (See Figure 7)	3.3	25	–	2.7	–	pF
D+, D- ON Capacitance, $C_{COM(ON)}$	$f = 1\text{ MHz}$, V_{Dpx} or $V_{Dnx} = V_{COM} = 0\text{ V}$ (See Figure 7)	3.3	25	–	8.9	–	pF
Differential Insertion Loss, D_{IL}	$f = 10\text{ MHz}$	3.3	25	–	-0.22	–	dB
	$f = 800\text{ MHz}$	3.3	25	–	-3.3	–	
Differential OFF-Isolation, D_{ISO}	$f = 10\text{ MHz}$	3.3	25	–	-44	–	dB
	$f = 800\text{ MHz}$	3.3	25	–	-16	–	
Differential Crosstalk, D_{CTK}	$f = 10\text{ MHz}$	3.3	25	–	-44	–	dB
	$f = 800\text{ MHz}$	3.3	25	–	-16	–	

POWER SUPPLY CHARACTERISTICS

Power Supply Range, V_{DD}		3.3	Full	3	–	3.6	V
Positive Supply Current, I_+	$V_{EN} = 0\text{ V}$, $V_{SEL} = 0\text{ V}$ or V_{DD}	3.6	25	–	54	65	μA
			Full	–	59	–	
	$V_{EN} = V_{DD}$, $V_{SEL} = 0\text{ V}$ or V_{DD}	3.6	25	–	14	40	μA
			Full	–	15	–	
	$V_{EN} = 0\text{ V}$, $V_{SEL} = 1.8\text{ V}$	3.6	25	–	55	65	μA
Full			–	58	–		

- V_{IN} = input voltage to perform proper function.
- The algebraic convention, whereby the most negative value is a minimum and the most positive a maximum, is used in this data sheet.
- Parameters with MIN and/or MAX limits are 100% tested at +25°C, unless otherwise specified. Temperature limits established by characterization and are not production tested.
- Flatness is defined as the difference between maximum and minimum value of ON-resistance at the specified analog signal voltage points.
- Limits established by characterization and are not production tested.
- r_{ON} matching between channels is calculated by subtracting the channel with the highest max r_{ON} value from the channel with lowest max r_{ON} value.
- Crosstalk is inversely proportional to source impedance.

DC ELECTRICAL CHARACTERISTICS – Digital Section (Voltages referenced to GND): $V_{DD} = +3.0\text{ V to }+3.6\text{ V}$, $GND = 0\text{ V}$, $V_S = 2\text{ V}_{RMS}$, $R_{LOAD} = 20\text{ k}\Omega$, $f = 1\text{ kHz}$, $V_{SELH} = V_{ENH} = 1.4\text{ V}$, $V_{SELL} = V_{ENL} = 0.5\text{ V}$, (Note 9), Unless otherwise specified.

Parameter	Test Conditions	Supply (V)	Temp (°C)	Min (Notes 10, 11)	Typ	Max (Notes 10, 11)	Units
DIGITAL INPUT CHARACTERISTICS							
Input Voltage Low, V_{SELL} , V_{ENL}		3.3	Full	–	–	0.5	V
Input Voltage High, V_{SELH} , V_{ENH}		3.3	Full	1.4	–	–	V
Input Current, I_{SELH} , I_{SELL}	$V_{EN} = 0\text{ V}$, $V_{SEL} = 0\text{ V}$ or V_{DD}	3.6	Full	-0.5	0.01	0.5	μA
Input Current, I_{ENL}	$V_{SEL} = V_{DD}$, $V_{EN} = 0\text{ V}$	3.6	Full	-1.3	-0.7	0.3	μA
Input Current, I_{ENH}	$V_{SEL} = 0\text{ V}$, $V_{EN} = V_{DD}$	3.6	Full	-0.5	0.01	0.5	μA

- V_{IN} = input voltage to perform proper function.
- The algebraic convention, whereby the most negative value is a minimum and the most positive a maximum, is used in this data sheet.
- Parameters with MIN and/or MAX limits are 100% tested at +25°C, unless otherwise specified. Temperature limits established by characterization and are not production tested.

TEST CIRCUITS AND WAVEFORMS

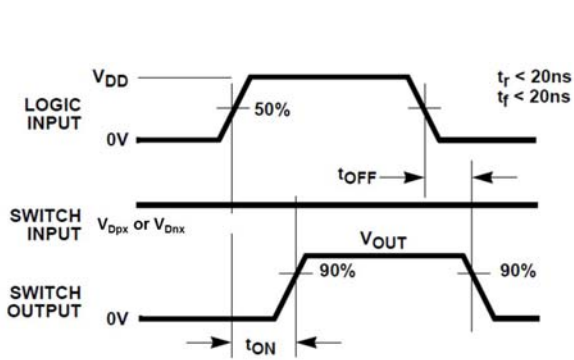

Logic input waveform is inverted for switches that have the opposite logic sense.

Measurement Points

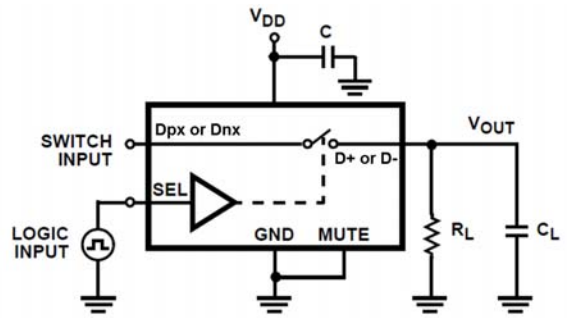

Repeat test for all switches. C_L includes fixture and stray capacitance.

$$V_{OUT} = V_{(Dpx \text{ or } Dnx)} \frac{R_L}{R_L + r_{ON}}$$

Test Circuit

Figure 2. Switching Times

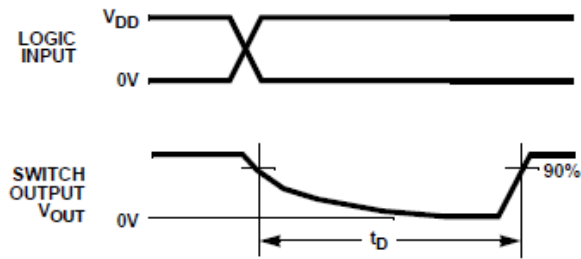

Measurement Points

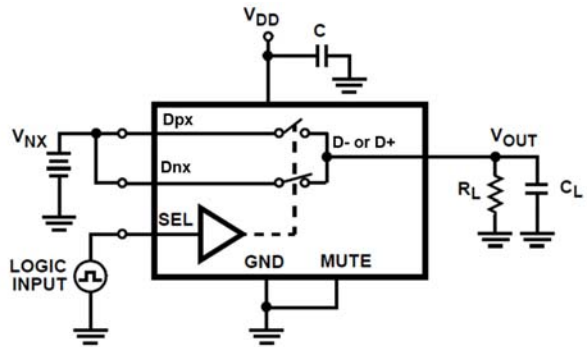

Repeat test for all switches. C_L includes fixture and stray capacitance.

Test Circuit

Figure 3. Break-Before-Make Time

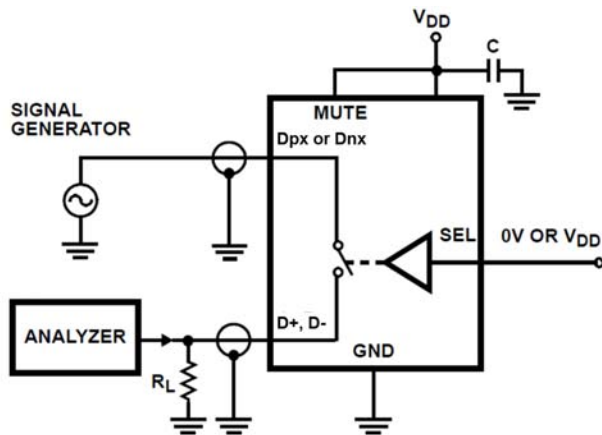

Signal direction through switch is reversed, worst case values are recorded. Repeat test for all switches.

Figure 4. Off-Isolation Test Circuit

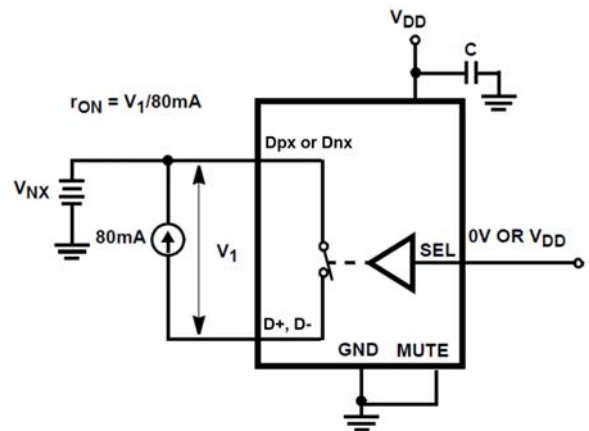

Repeat test for all switches.

Figure 5. r_{ON} Test Circuit

TEST CIRCUITS AND WAVEFORMS

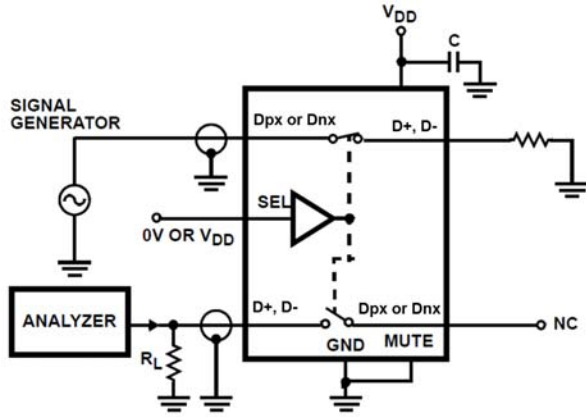

Signal direction through switch is reversed, worst case values are recorded. Repeat test for all switches.

Figure 6. Crosstalk Test Circuit

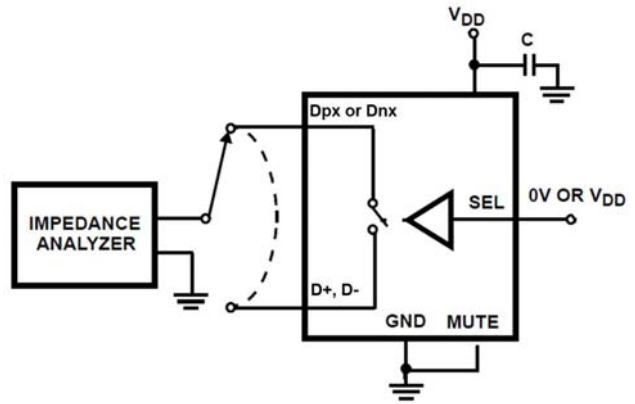

Repeat test for all switches.

Figure 7. Capacitance Test Circuit

TYPICAL PERFORMANCE CURVES:

$T_A = +25^\circ\text{C}$, Unless Otherwise Specified

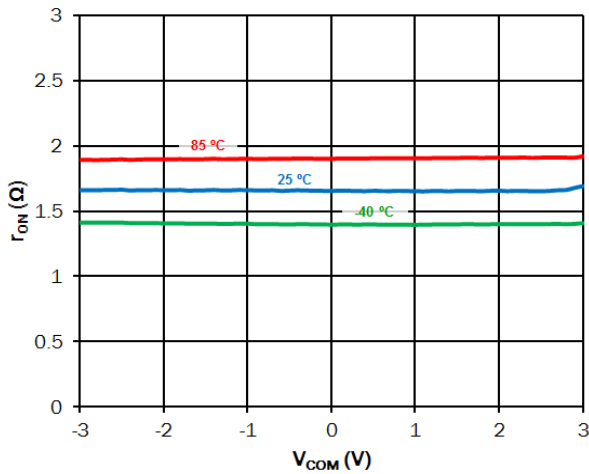

Figure 8. On-Resistance vs. Switch Voltage

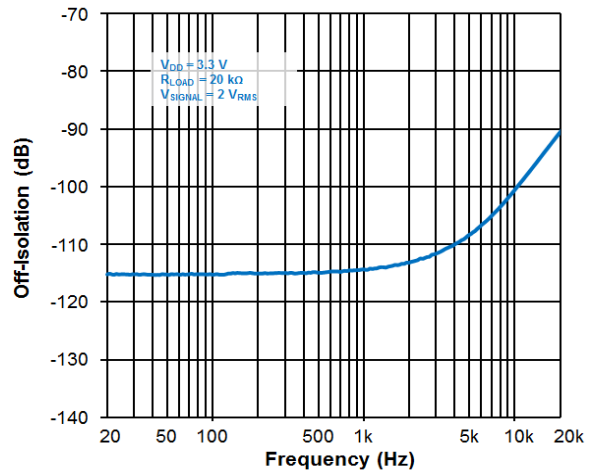

Figure 9. Off-Isolation, 2 V_{RMS} Signal, 20 $k\Omega$ Load

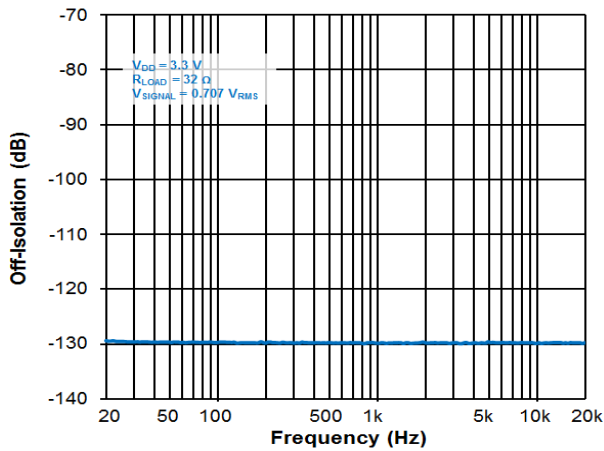

Figure 10. Off-Isolation, 0.707 V_{RMS} Signal, 32 $k\Omega$ Load

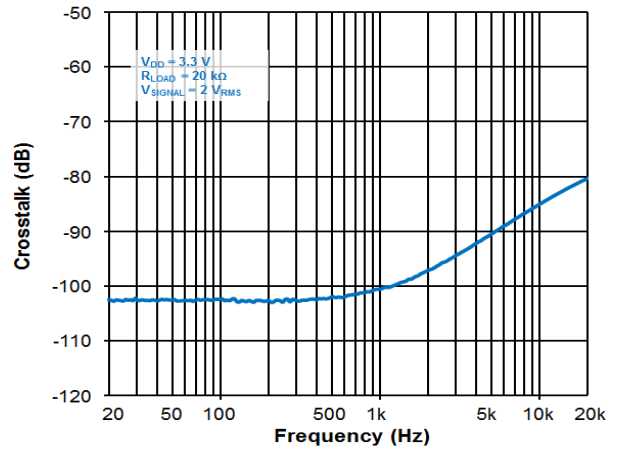

Figure 11. Channel-to-Channel Crosstalk

NL3S588

TYPICAL PERFORMANCE CURVES:

$T_A = +25^\circ\text{C}$, Unless Otherwise Specified

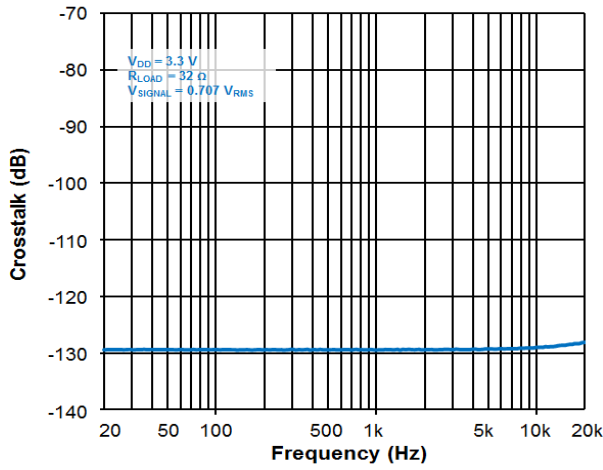

Figure 12. Channel-to-Channel Crosstalk

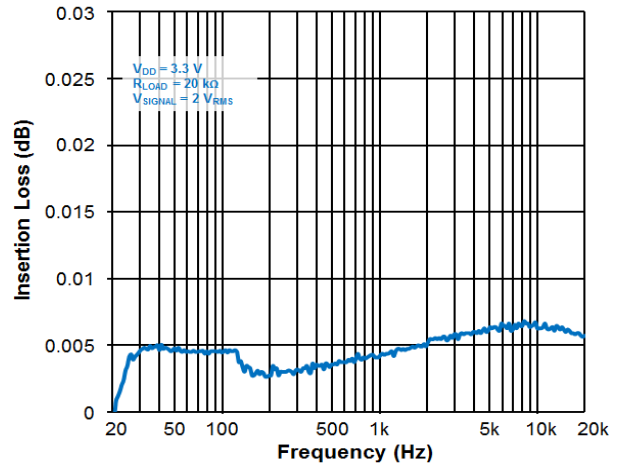

Figure 13. Insertion Loss vs. Frequency

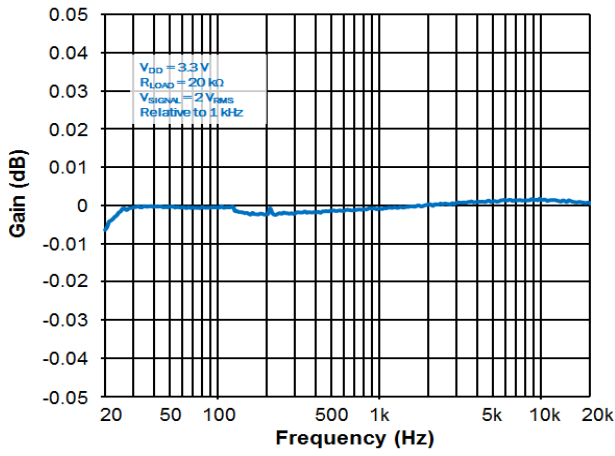

Figure 14. Gain vs. Frequency

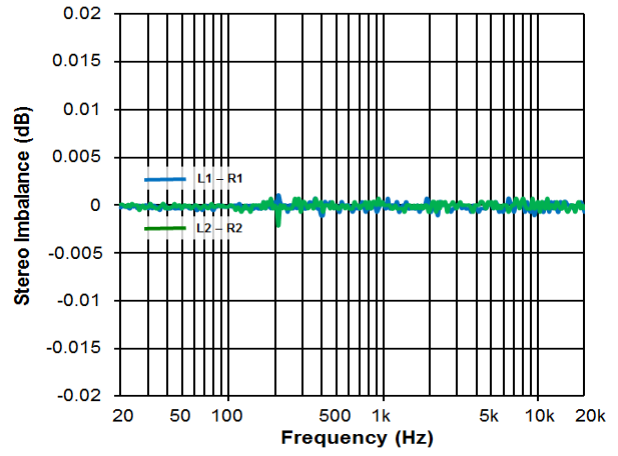

Figure 15. Stereo Imbalance vs. Frequency

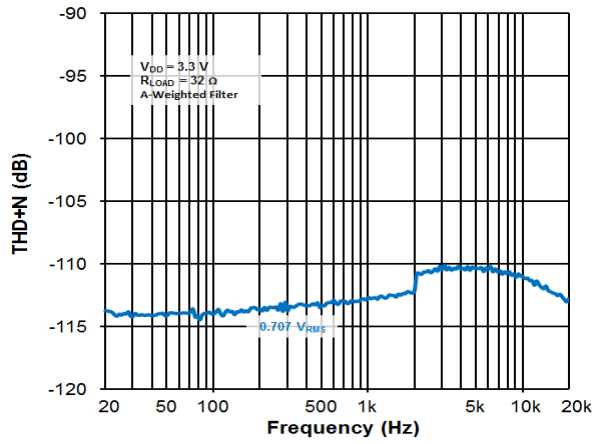

Figure 16. THD+N vs. Signal Levels vs. Frequency

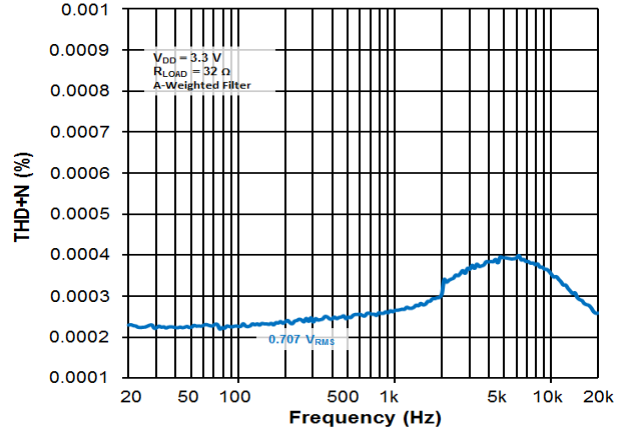

Figure 17. THD+N vs. Signal Levels vs. Frequency

TYPICAL PERFORMANCE CURVES:

T_A = +25°C, Unless Otherwise Specified

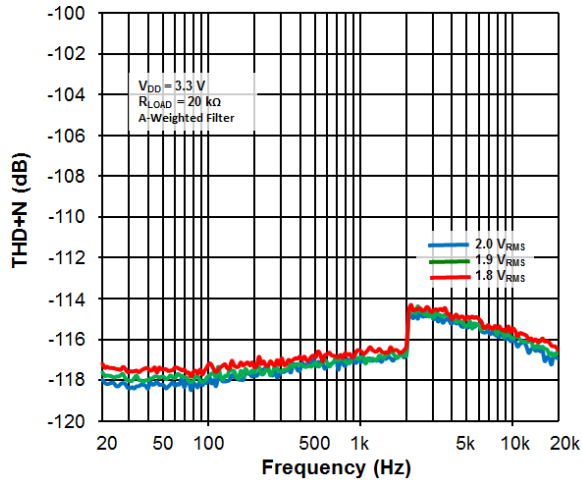

Figure 18. THD+N vs. Signal Levels vs. Frequency

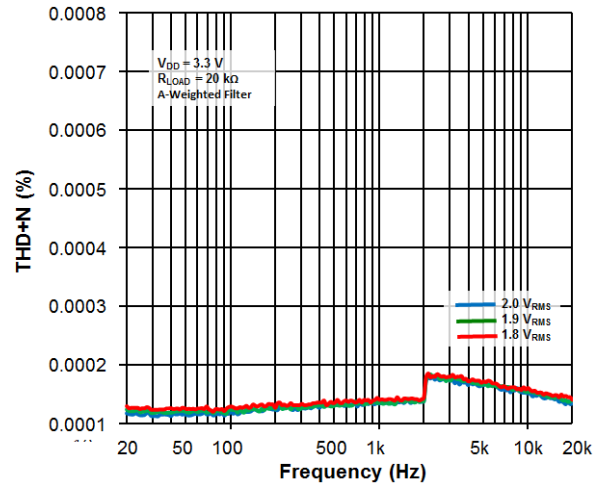

Figure 19. THD+N vs. Signal Levels vs. Frequency

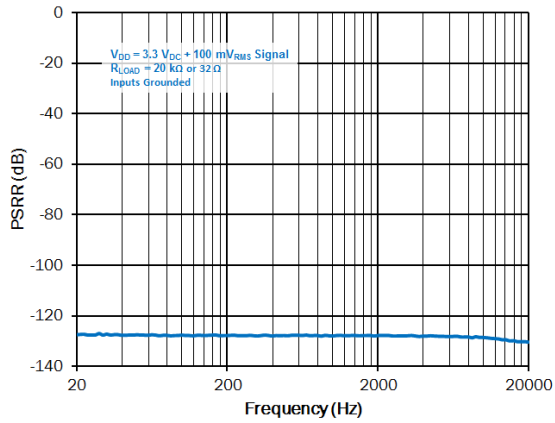

Figure 20. PSRR vs. Frequency

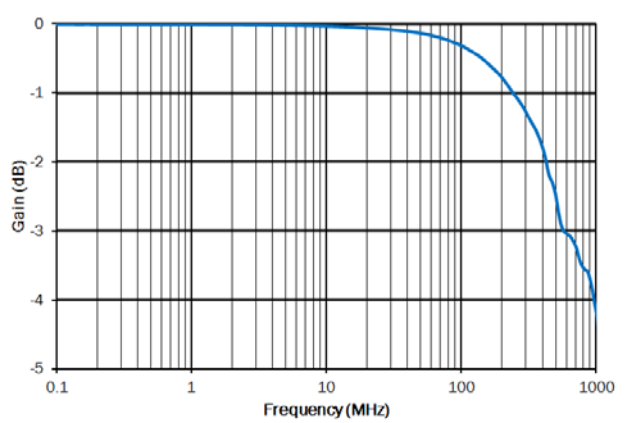

Figure 21. Frequency Response

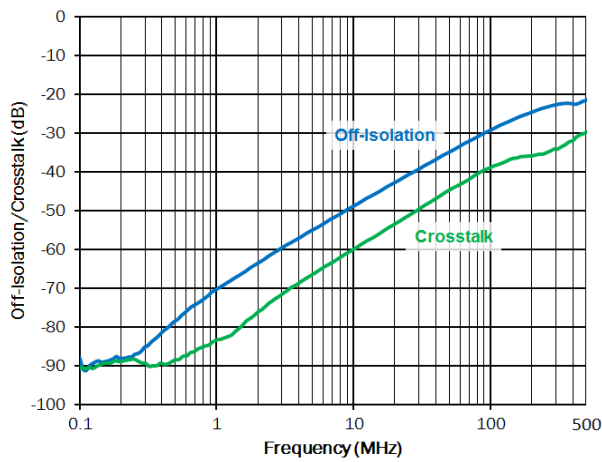

Figure 22. Crosstalk and Off-Isolation

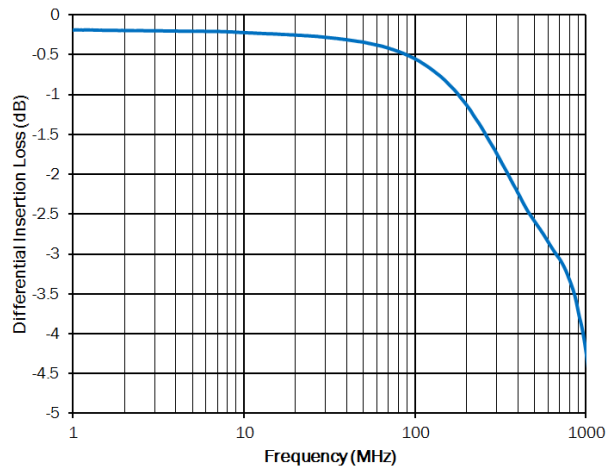

Figure 23. Differential Crosstalk

NL3S588

TYPICAL PERFORMANCE CURVES:

$T_A = +25^\circ\text{C}$, Unless Otherwise Specified

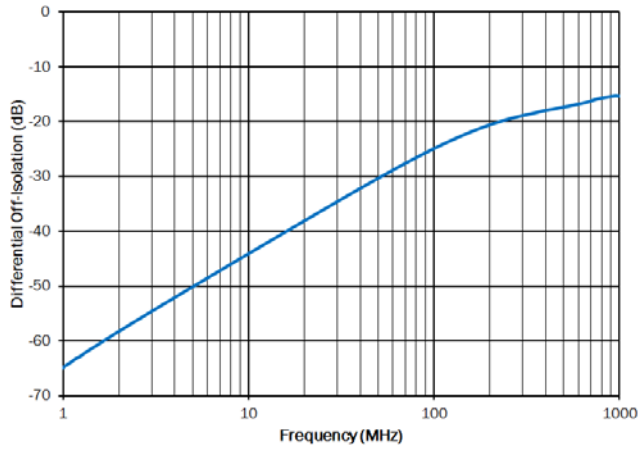

Figure 24. Differential Off-Isolation

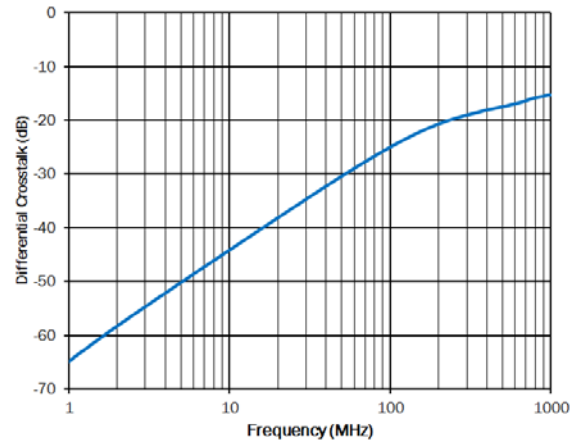

Figure 25. Differential Crosstalk

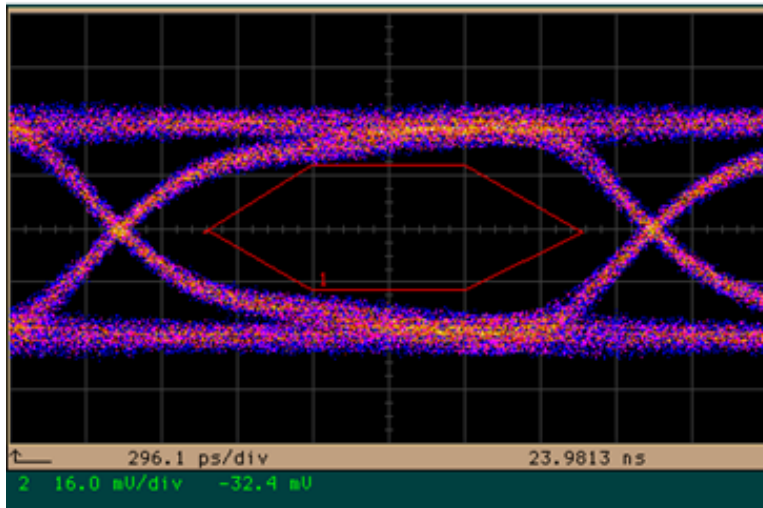
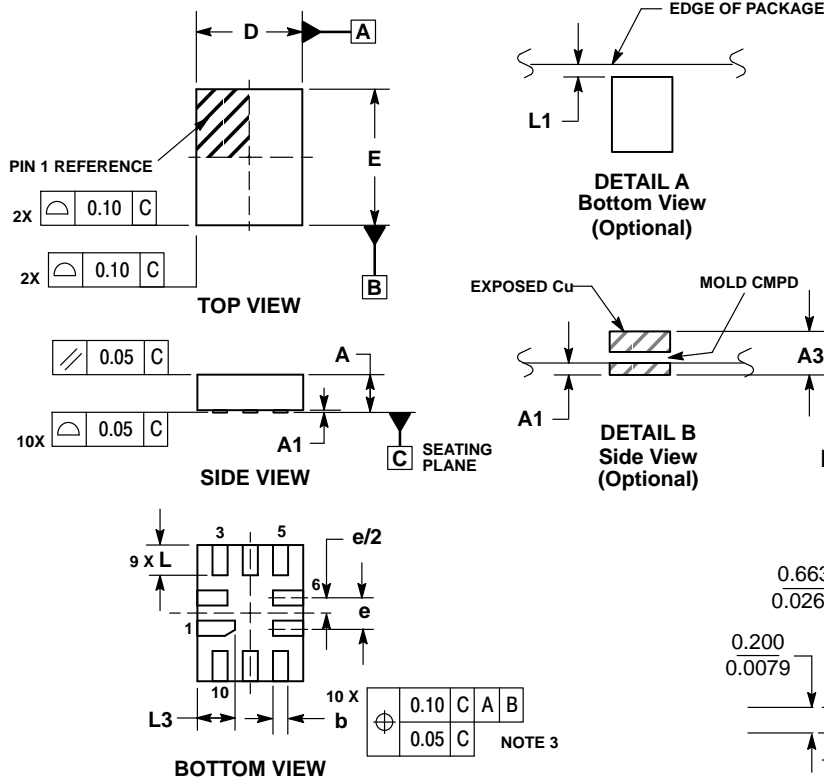

Figure 26. USB 2.0 High-Speed Eye Diagram

NL3S588

PACKAGE DIMENSIONS

UQFN10 1.4x1.8, 0.4P CASE 488AT ISSUE A



NOTES:

1. DIMENSIONING AND TOLERANCING PER ASME Y14.5M, 1994.
2. CONTROLLING DIMENSION: MILLIMETERS
3. DIMENSION b APPLIES TO PLATED TERMINAL AND IS MEASURED BETWEEN 0.25 AND 0.30 MM FROM TERMINAL.
4. COPLANARITY APPLIES TO THE EXPOSED PAD AS WELL AS THE TERMINALS.

MILLIMETERS		
DIM	MIN	MAX
A	0.45	0.60
A1	0.00	0.05
A3	0.127 REF	
b	0.15	0.25
D	1.40 BSC	
E	1.80 BSC	
e	0.40 BSC	
L	0.30	0.50
L1	0.00	0.15
L3	0.40	0.60

MOUNTING FOOTPRINT*

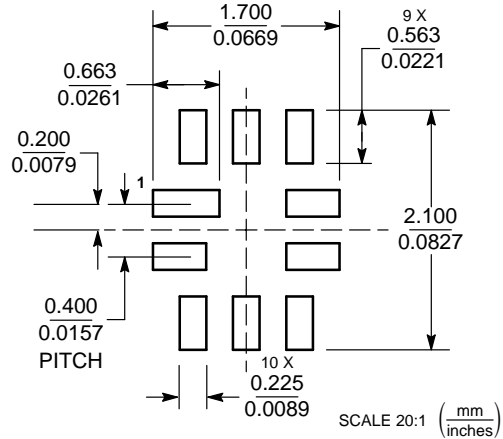

*For additional information on our Pb-Free strategy and soldering details, please download the ON Semiconductor Soldering and Mounting Techniques Reference Manual, SOLDERRM/D.

ON Semiconductor and are trademarks of Semiconductor Components Industries, LLC dba ON Semiconductor or its subsidiaries in the United States and/or other countries. ON Semiconductor owns the rights to a number of patents, trademarks, copyrights, trade secrets, and other intellectual property. A listing of ON Semiconductor's product/patent coverage may be accessed at www.onsemi.com/site/pdf/Patent-Marking.pdf. ON Semiconductor reserves the right to make changes without further notice to any products herein. ON Semiconductor makes no warranty, representation or guarantee regarding the suitability of its products for any particular purpose, nor does ON Semiconductor assume any liability arising out of the application or use of any product or circuit, and specifically disclaims any and all liability, including without limitation special, consequential or incidental damages. Buyer is responsible for its products and applications using ON Semiconductor products, including compliance with all laws, regulations and safety requirements or standards, regardless of any support or applications information provided by ON Semiconductor. "Typical" parameters which may be provided in ON Semiconductor data sheets and/or specifications can and do vary in different applications and actual performance may vary over time. All operating parameters, including "Typicals" must be validated for each customer application by customer's technical experts. ON Semiconductor does not convey any license under its patent rights nor the rights of others. ON Semiconductor products are not designed, intended, or authorized for use as a critical component in life support systems or any FDA Class 3 medical devices or medical devices with a same or similar classification in a foreign jurisdiction or any devices intended for implantation in the human body. Should Buyer purchase or use ON Semiconductor products for any such unintended or unauthorized application, Buyer shall indemnify and hold ON Semiconductor and its officers, employees, subsidiaries, affiliates, and distributors harmless against all claims, costs, damages, and expenses, and reasonable attorney fees arising out of, directly or indirectly, any claim of personal injury or death associated with such unintended or unauthorized use, even if such claim alleges that ON Semiconductor was negligent regarding the design or manufacture of the part. ON Semiconductor is an Equal Opportunity/Affirmative Action Employer. This literature is subject to all applicable copyright laws and is not for resale in any manner.

PUBLICATION ORDERING INFORMATION

LITERATURE FULFILLMENT:

Literature Distribution Center for ON Semiconductor
19521 E. 32nd Pkwy, Aurora, Colorado 80011 USA
Phone: 303-675-2175 or 800-344-3860 Toll Free USA/Canada
Fax: 303-675-2176 or 800-344-3867 Toll Free USA/Canada
Email: orderlit@onsemi.com

N. American Technical Support: 800-282-9855 Toll Free
USA/Canada
Europe, Middle East and Africa Technical Support:
Phone: 421 33 790 2910
Japan Customer Focus Center
Phone: 81-3-5817-1050

ON Semiconductor Website: www.onsemi.com

Order Literature: <http://www.onsemi.com/orderlit>

For additional information, please contact your local Sales Representative