

NTH4L080N120SC1

Product Preview

N-Channel Silicon Carbide MOSFET

1200 V, 80.9 mΩ, 50.4 A

MAXIMUM RATINGS (T_J = 25°C unless otherwise noted)

Parameter	Symbol	Value	Unit
Drain-to-Source Voltage	V _{DSS}	1200	V
Gate-to-Source Voltage	V _{GS}	±20	V
Continuous Drain Current R _{θJC}	I _{DC}	50.4	A
Power Dissipation R _{θJC}			
Continuous Drain Current R _{θJC}	I _{DC}	35.6	A
Power Dissipation R _{θJC}			
Continuous Drain Current R _{θJA}	I _{DA}	TBD	A
Power Dissipation R _{θJA}			
Continuous Drain Current R _{θJA}	I _{DA}	TBD	A
Power Dissipation R _{θJA}			
Pulsed Drain Current R _{θJC}	I _{DM}	238	A
Operating Junction and Storage Temperature Range	T _J , T _{stg}	-55 to +175	°C
Source Current (Body Diode)	I _S	65.7	A
Single Pulse Avalanche Energy (T _J = 25°C, V _{GS} = 20 V, I _{LPK} = 1 A, L = 0.1 mH, R _G = 25 Ω)	E _{AS}	TBD	mJ
Lead Temperature for Soldering Purposes	T _L	TBD	°C

Stresses exceeding those listed in the Maximum Ratings table may damage the device. If any of these limits are exceeded, device functionality should not be assumed, damage may occur and reliability may be affected.

THERMAL CHARACTERISTICS

Parameter	Symbol	Value	Unit
Thermal Resistance, Junction-to-Case	R _{θJC}	0.48	°C/W
Thermal Resistance, Junction-to-Ambient	R _{θJA}	TBD	

This document contains information on a product under development. ON Semiconductor reserves the right to change or discontinue this product without notice.



ON Semiconductor®

www.onsemi.com

V _{(BR)DSS}	R _{DS(on)}	I _D
1200 V	80.9 mΩ @ 20 V	50.4 A

N-CHANNEL MOSFET

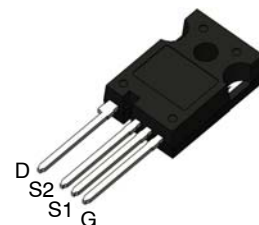
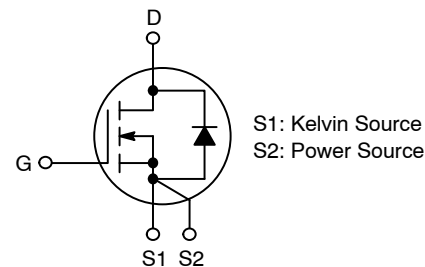

TO-247-4LD
CASE 340CJ

MARKING DIAGRAM



&Z = Assembly Plant Code
&3 = Data Code (Year & Week)
&K = Lot
NTH4L080N120SC1 = Specific Device Code

ORDERING INFORMATION

See detailed ordering and shipping information on page 2 of this data sheet.

NTH4L080N120SC1

ELECTRICAL CHARACTERISTICS

Parameter	Symbol	Test Conditions	Min	Typ	Max	Unit
-----------	--------	-----------------	-----	-----	-----	------

OFF CHARACTERISTICS

Drain-to-Source Breakdown Voltage	$V_{(BR)DSS}$	$V_{GS} = 0\text{ V}, I_D = 2.50\text{e} - 04\text{A}, T_C = 25^\circ\text{C}$	1200	-	-	V
Drain-to-Source Breakdown Voltage Temperature Coefficient	$V_{(BR)DSS}T_J$	$V_{GS} = 0\text{ V}, I_D = 2.50\text{e} - 04\text{A}, T_{Jmax} = 175^\circ\text{C}$	-	0.25	-	V/°C
Zero Gate Voltage Drain Current	I_{DSS}	$T_C = 25^\circ\text{C}$	-	-	10.0	μA
		$T_C = 175^\circ\text{C}$	-	-	250	
Gate-to-Source Leakage Current	I_{GSS}	$V_G = 20\text{ V}, V_D = 0\text{ V}$	-	-	250	nA

ON CHARACTERISTICS

Drain-to-Source On Resistance	$R_{DS(on)}$	$V_G = 20\text{ V}, I_D = 20.1\text{ A}$	-	80.9	-	m Ω
Gate Threshold Voltage	$V_{GS(th)}$	$V_G = V_D, I_D = 5.04\text{e} - 03\text{A}$	-	2.83	-	V
Gate Threshold Voltage Temperature Coefficient	$V_{GS(th)}/T_J$		-	-5.37	-	mV/°C
Forward Transconductance	g_{FS}	$V_D = 10.0\text{ V}, I_D = 20.1\text{ A}$	-	8.02	-	S

CHARGES, CAPACITANCES & GATE RESISTANCE

Gate Resistance	R_G	$V_G = 0\text{ V}, V_D = 1000\text{ V}$	-	3.32	-	Ω
Input Capacitance	C_{ISS}		-	1286	-	pF
Reverse Transfer Capacitance	C_{RSS}		-	3.89	-	
Output Capacitance	C_{OSS}		-	74.9	-	
Effective Output Capacitance	C_{OSSef}	$V_{DS} = 0\text{ to }1000\text{ V}, V_G = 0\text{ V}$	-	122	-	
Energy Related Output Capacitance	C_{OSSer}		-	89.9	-	
Coss Stored Energy	E_{OSS}		-	44.9	-	μJ
Total Gate Charge	$Q_{G(tot)}$	$V_D = 800\text{ V}, I_D = 10.1\text{ A}, V_G = 20\text{ V}$	-	46.6	-	nC
Gate-to-Source Charge	Q_{GS}		-	11.0	-	
Gate-to-Drain Charge	Q_{GD}		-	11.5	-	

SWITCHING CHARACTERISTICS

Turn-On Delay Time	$t_{d(on)}$	$V_G = -5/20\text{ V}, I_D = 20.1\text{ A}, V_D = 800\text{ V}, R_G = 2\text{ }\Omega$	-	-6.21	-	ns
Turn-Off Delay Time	$t_{d(off)}$		-	13.8	-	
Rise Time	t_r		-	4.13	-	
Fall Time	t_f		-	7.14	-	
Turn-On Switching Loss	E_{ON}			-	0.13	-
Turn-Off Switching Loss	E_{OFF}		-	0.03	-	
Total Switching Loss	E_{TOT}		-	0.17	-	

DRAIN-SOURCE DIODE CHARACTERISTICS

Forward Diode Voltage	V_{SD}	$I_D = 10.1\text{ A}$	-	3.84	-	V
Reverse Recovery Time	t_{RR}	$I_D = 20.1\text{ A}, dI/dt = 1000\text{ A}/\mu\text{s}, V_{DS} = 800\text{ V}, V_{GS} = -5/20\text{ V}$	-	39.2	-	ns
Reverse Recovery Charge	Q_{RR}		-	144	-	nC
Reverse Recovery Energy	E_{REC}		-	37.4	-	μJ
Peak Reverse Recovery Current	I_{RRM}		-	6.99	-	A

Product parametric performance is indicated in the Electrical Characteristics for the listed test conditions, unless otherwise noted. Product performance may not be indicated by the Electrical Characteristics if operated under different conditions.

NTH4L080N120SC1

TYPICAL PERFORMANCE CHARACTERISTICS

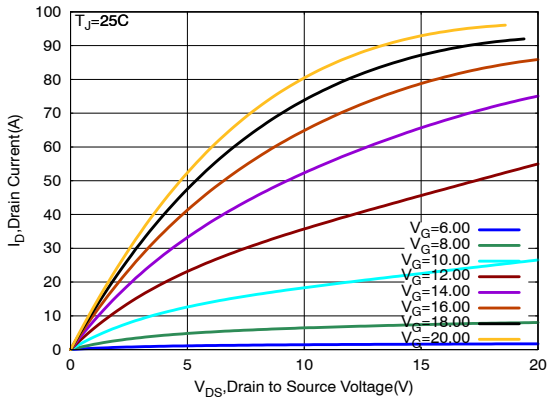

Figure 1. On-Region Characteristics

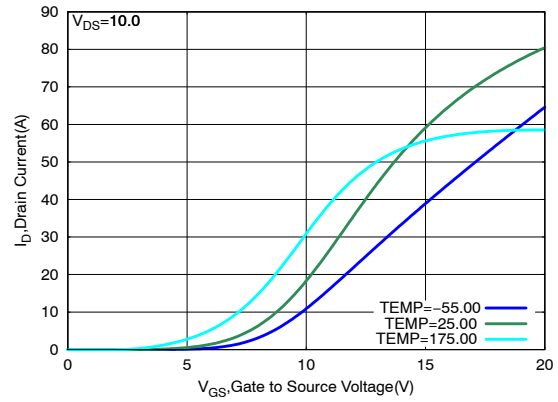

Figure 2. Transfer Characteristics

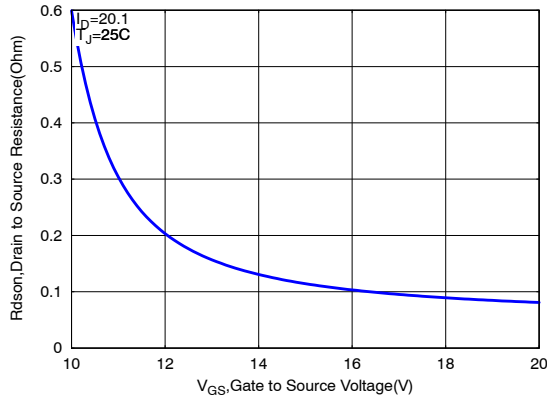

Figure 3. On-Resistance vs. VGS

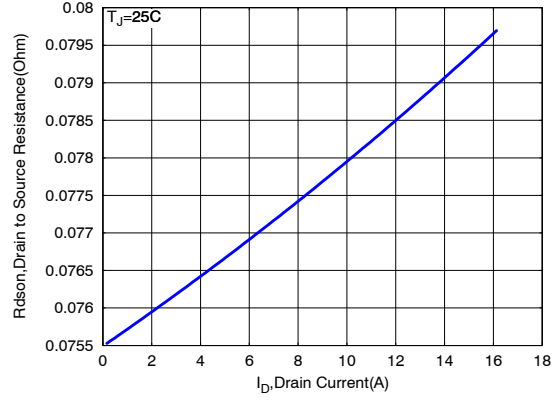

Figure 4. On-Resistance vs. Drain Current and Gate Voltage

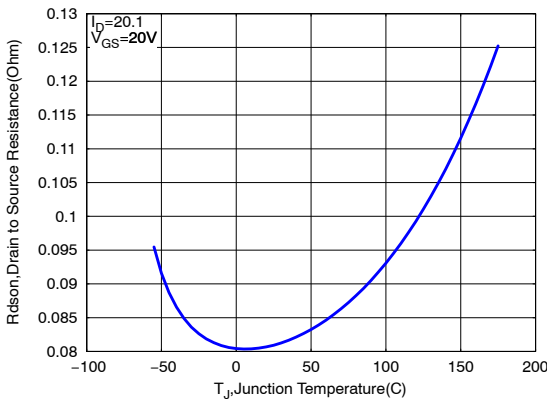

Figure 5. On-Resistance Variation with Temperature

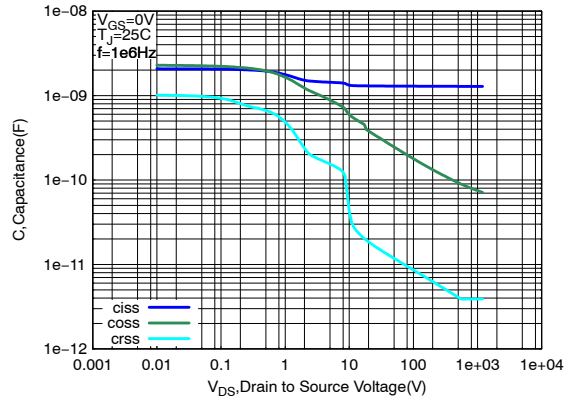

Figure 6. Capacitance Variation

NTH4L080N120SC1

TYPICAL PERFORMANCE CHARACTERISTICS

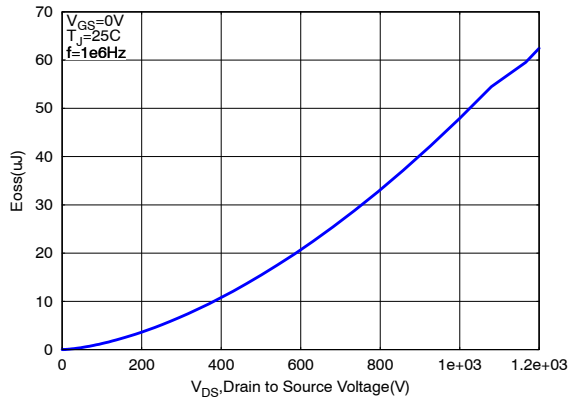

Figure 7. Eoss vs. Drain-to-Source Voltage

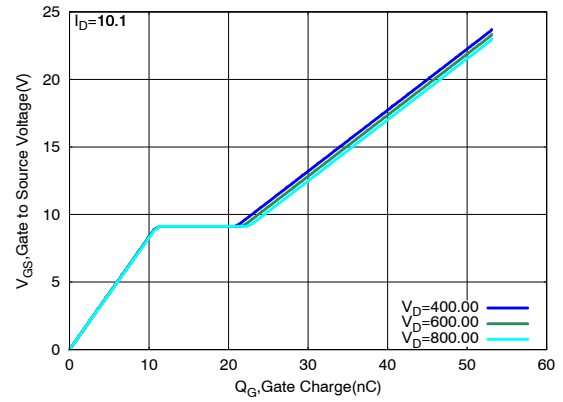

Figure 8. Gate-to-Source Voltage vs. Total Charge

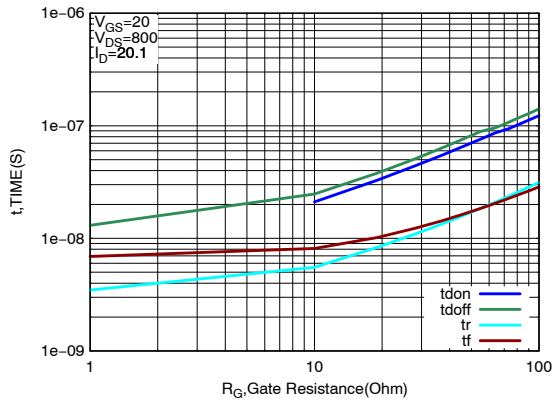

Figure 9. Resistive Switching Time Variation vs. Gate Resistance

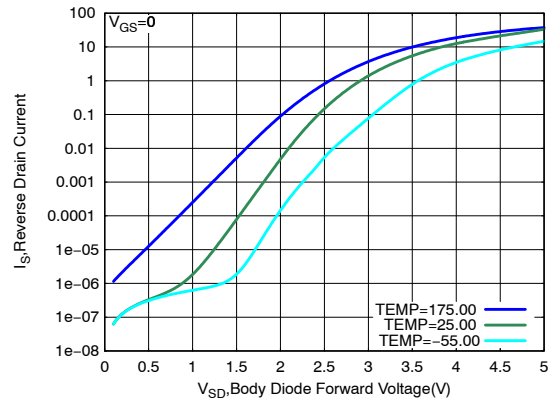

Figure 10. Diode Forward Voltage vs. Current

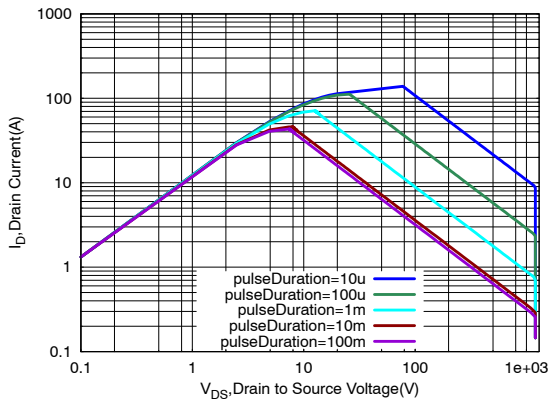

Figure 11. Maximum Rated Forward Biased Safe Operating Area

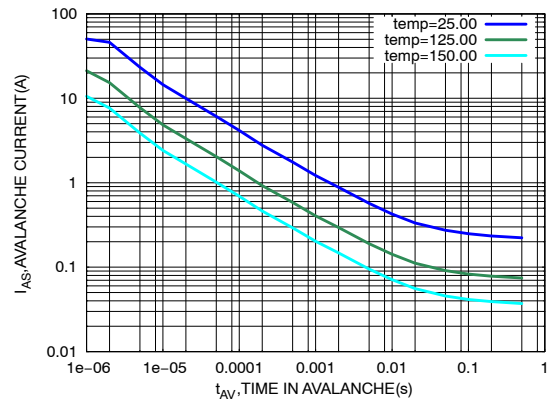

Figure 12. Ipeak vs. Time in Avalanche

NTH4L080N120SC1

TYPICAL PERFORMANCE CHARACTERISTICS

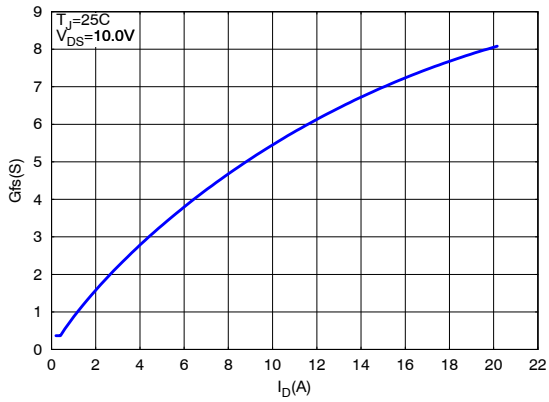

Figure 13. GFS vs. ID

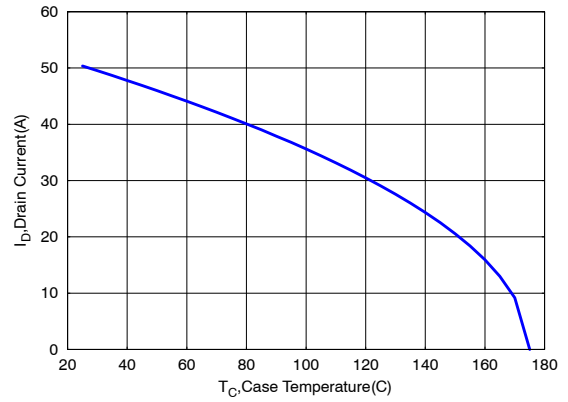

Figure 14. Maximum Current vs. Case Temperature

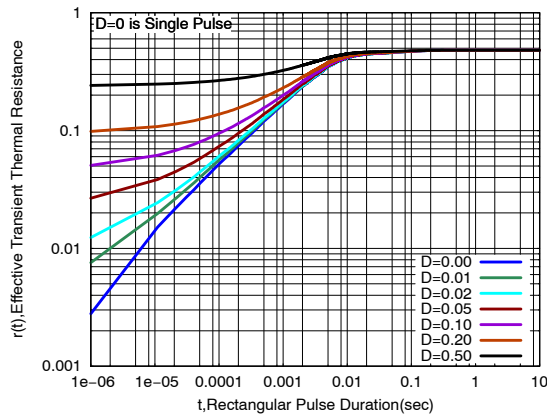

Figure 15. Thermal Response

PACKAGE MARKING AND ORDERING INFORMATION

Part Number	Top Marking	Package	Packing Method	Reel Size	Tape Width	Quantity
NTH4L080N120SC1	NTH4L080N120SC1	TO-247	Tube	N/A	N/A	30 Units

NTH4L080N120SC1

PACKAGE DIMENSIONS

TO-247-4LD
CASE 340CJ
ISSUE O

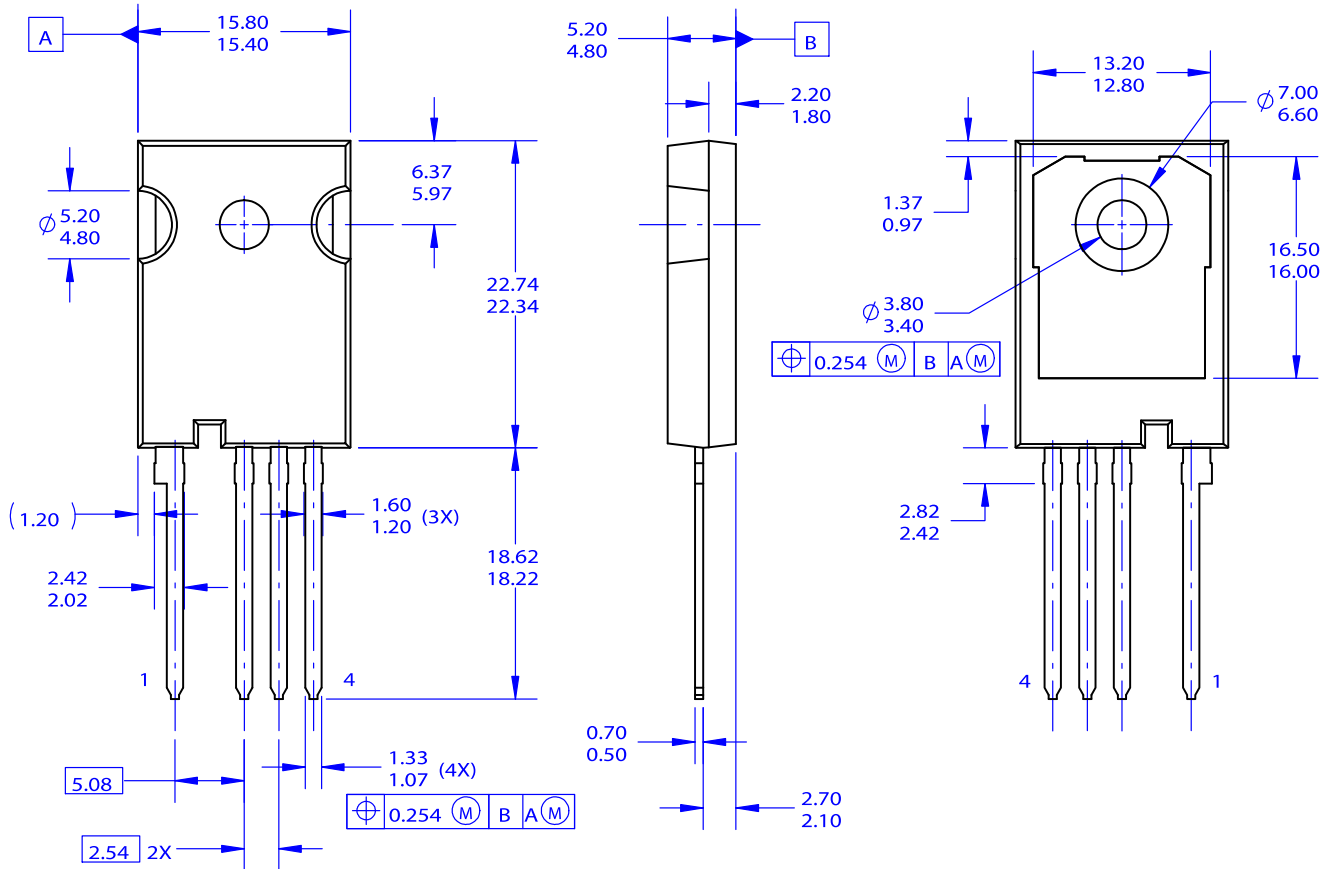

NOTES:

- A. NO INDUSTRY STANDARD APPLIES TO THIS PACKAGE.
- B. DIMENSIONS ARE EXCLUSIVE OF BURRS, MOLD FLASH, AND TIE BAR EXTRUSIONS.
- C. ALL DIMENSIONS ARE IN MILLIMETERS.
- D. DRAWING CONFORMS TO ASME Y14.5-2009.

ON Semiconductor and are trademarks of Semiconductor Components Industries, LLC dba ON Semiconductor or its subsidiaries in the United States and/or other countries. ON Semiconductor owns the rights to a number of patents, trademarks, copyrights, trade secrets, and other intellectual property. A listing of ON Semiconductor's product/patent coverage may be accessed at www.onsemi.com/site/pdf/Patent-Marking.pdf. ON Semiconductor reserves the right to make changes without further notice to any products herein. ON Semiconductor makes no warranty, representation or guarantee regarding the suitability of its products for any particular purpose, nor does ON Semiconductor assume any liability arising out of the application or use of any product or circuit, and specifically disclaims any and all liability, including without limitation special, consequential or incidental damages. Buyer is responsible for its products and applications using ON Semiconductor products, including compliance with all laws, regulations and safety requirements or standards, regardless of any support or applications information provided by ON Semiconductor. "Typical" parameters which may be provided in ON Semiconductor data sheets and/or specifications can and do vary in different applications and actual performance may vary over time. All operating parameters, including "Typicals" must be validated for each customer application by customer's technical experts. ON Semiconductor does not convey any license under its patent rights nor the rights of others. ON Semiconductor products are not designed, intended, or authorized for use as a critical component in life support systems or any FDA Class 3 medical devices or medical devices with a same or similar classification in a foreign jurisdiction or any devices intended for implantation in the human body. Should Buyer purchase or use ON Semiconductor products for any such unintended or unauthorized application, Buyer shall indemnify and hold ON Semiconductor and its officers, employees, subsidiaries, affiliates, and distributors harmless against all claims, costs, damages, and expenses, and reasonable attorney fees arising out of, directly or indirectly, any claim of personal injury or death associated with such unintended or unauthorized use, even if such claim alleges that ON Semiconductor was negligent regarding the design or manufacture of the part. ON Semiconductor is an Equal Opportunity/Affirmative Action Employer. This literature is subject to all applicable copyright laws and is not for resale in any manner.

PUBLICATION ORDERING INFORMATION

LITERATURE FULFILLMENT:
Literature Distribution Center for ON Semiconductor
19521 E. 32nd Pkwy, Aurora, Colorado 80011 USA
Phone: 303-675-2175 or 800-344-3860 Toll Free USA/Canada
Fax: 303-675-2176 or 800-344-3867 Toll Free USA/Canada
Email: orderlit@onsemi.com

N. American Technical Support: 800-282-9855 Toll Free
USA/Canada
Europe, Middle East and Africa Technical Support:
Phone: 421 33 790 2910

ON Semiconductor Website: www.onsemi.com
Order Literature: <http://www.onsemi.com/orderlit>

For additional information, please contact your local Sales Representative