

P2027A

General Purpose EMI Reduction IC

Description

The P2027 is a versatile spread spectrum frequency modulator designed specifically for digital camera and other digital video and imaging applications. The P2027 reduces electromagnetic interference (EMI) at the clock source, which provides system wide reduction of EMI of all clock dependent signals. The P2027 allows significant system cost savings by reducing the number of circuit board layers and shielding that are traditionally required to pass EMI regulations.

The P2027 uses the most efficient and optimized modulation profile approved by the FCC and is implemented in a proprietary all-digital method.

The P2027 modulates the output of a single PLL in order to “spread” the bandwidth of a synthesized clock and, more importantly, decreases the peak amplitudes of its harmonics. This results in significantly lower system EMI compared to the typical narrow band signal produced by oscillators and most frequency generators. Lowering EMI by increasing a signal’s bandwidth is called ‘spread spectrum clock generation.’

Applications

The P2027 is targeted towards DSC market as well as other imaging and digital video applications like DVD and VCD players.

Features

- FCC Approved Method of EMI Attenuation
- Provides up to 20 dB of EMI Suppression
- Generates a Low EMI Spread Spectrum Clock of the Input Frequency
- Optimized for 27 MHz Operation
- Internal Loop Filter Minimizes External Components and Board Space
- 3 Selectable Spread Ranges and 2 Modulation Rate Options
- SSON Control Pin for Spread Spectrum Enable and Disable Options
- Low Cycle-to-Cycle Jitter
- 3.3 V Operating Voltage
- 16 mA Output Drives
- TTL or CMOS Compatible Outputs
- Low Power CMOS Design
- Supports Digital Camera and Other Digital Video and Imaging Applications
- Available in 8-pin SOIC and TSSOP Packages
- These are Pb-Free Devices



ON Semiconductor®

<http://onsemi.com>



SOIC-8
S SUFFIX
CASE 751BD



TSSOP-8
T SUFFIX
CASE 948AL

PIN CONFIGURATION

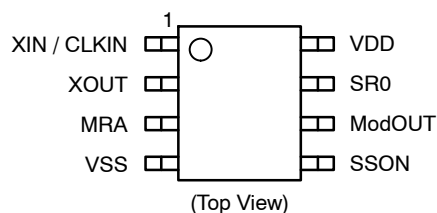

ORDERING INFORMATION

See detailed ordering and shipping information in the package dimensions section on page 7 of this data sheet.

P2027A

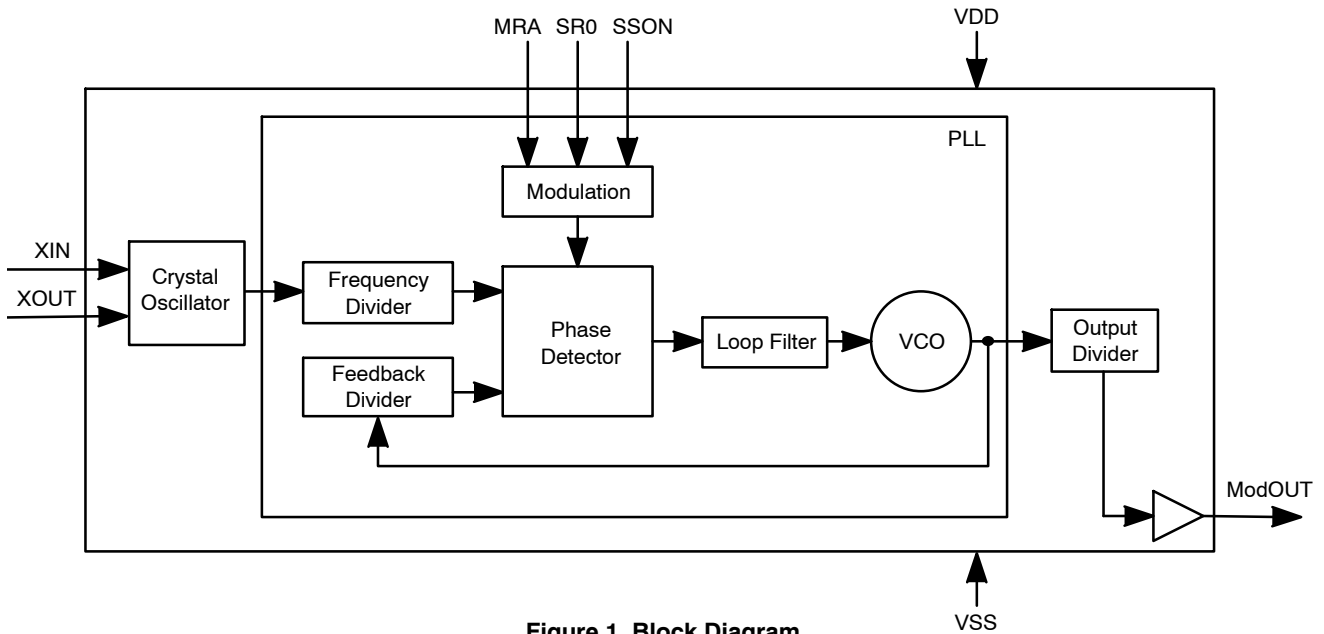

Figure 1. Block Diagram

Table 1. PIN DESCRIPTION

Pin#	Pin Name	Type	Description
1	XIN / CLKIN	I	Crystal connection or external reference frequency input. This pin has dual functions. It can be connected to either an external crystal or an external reference clock.
2	XOUT	O	Crystal connection. Input connection for an external crystal. If using an external reference, this pin must be left unconnected.
3	MRA	I	Digital logic input used to select Modulation Rate (see Table 2). This pin has an internal pull-up resistor.
4	VSS	P	Ground Connection. Connect to system ground.
5	SSON	I	Digital logic input used to enable Spread Spectrum function (Active Low). Spread Spectrum function enable when low. This pin has an internal pull-low resistor.
6	ModOUT	O	Spread Spectrum Clock Output.
7	SR0	I	Digital logic input used to select Spreading Range (see Table 2). This pin has an internal pull-up resistor.
8	VDD	P	Connect to +3.3 V Power Supply.

Table 2. MODULATION AND SPREADING SELECTION

MRA	SR0	Spread Range	Modulation Rate
0	0	Reserve	Reserve
0	1	±0.30%	$(F_{in}/10) * 34.72$ KHz
1	0	±0.20%	$(F_{in}/10) * 20.83$ KHz
1	1	±0.60%	$(F_{in}/10) * 20.83$ KHz

P2027A

Spread Spectrum Selection

Table 2 illustrates the possible spread spectrum options. The optimal setting should minimize system EMI to the fullest without affecting system performance. The spreading is described as a percentage deviation of the center frequency (Note: the center frequency is the frequency of the external reference input on CLKIN, Pin 1).

Example:

P2027 is designed for DSC and digital video and imaging markets and is optimized for 27 MHz under minimum deviation settings. Selecting P2027's spread options to MRA=1 and SR0=1 for a 27 MHz input signal provides a percentage deviation of $\pm 0.60\%$ (see Table 2) from the reference signal. This results in frequency on ModOUT being swept from 27.16 MHz to 26.84 MHz at a modulation rate of 56.24 KHz (see Table 2). This particular example (see the below figure) given here is a new EMI reduction method for DSC applications and is already gaining popularity among leading manufacturers.

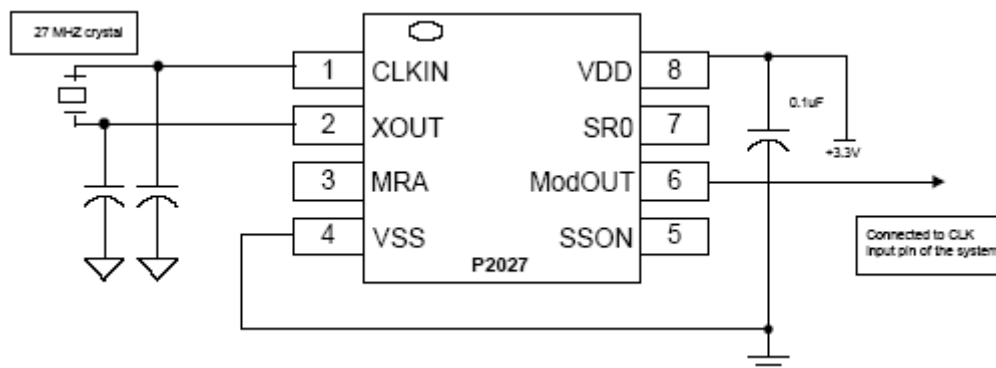

Figure 2. Application Schematic for Digital Still Camera

Table 3. ABSOLUTE MAXIMUM RATINGS

Symbol	Parameter	Rating	Unit
VDD, V _{IN}	Voltage on any pin with respect to Ground	-0.5 to +4.6	V
T _{STG}	Storage temperature	-65 to +125	°C
T _A	Operating temperature	0 to 70	°C
T _s	Max. Soldering Temperature (10 sec)	260	°C
T _J	Junction Temperature	150	°C
T _{DV}	Static Discharge Voltage (As per JEDEC STD22- A114-B)	2	KV

Stresses exceeding Maximum Ratings may damage the device. Maximum Ratings are stress ratings only. Functional operation above the Recommended Operating Conditions is not implied. Extended exposure to stresses above the Recommended Operating Conditions may affect device reliability.

Table 4. DC ELECTRICAL CHARACTERISTICS

Symbol	Parameter	Min	Typ	Max	Unit
V _{IL}	Input Low Voltage	GND-0.3	-	0.8	V
V _{IH}	Input High Voltage	2.0	-	V _{DD} + 0.3	V
I _{IL}	Input Low Current (pull-up resistor on inputs FS0, SR0 and MRA)	-	-	-35	μA
I _{IH}	Input High Current (pull-down resistor on input SSON)	-	-	35	μA
I _{XOL}	XOUT Output Low Current (@ 0.4 V, V _{DD} = 3.3 V)	-	3	-	mA
I _{XOH}	XOUT Output High Current (@ 2.5 V, V _{DD} = 3.3 V)	-	3	-	mA
V _{OL}	Output Low Voltage (V _{DD} = 3.3 V, I _{OL} = 20 mA)	-	-	0.4	V
V _{OH}	Output High Voltage (V _{DD} = 3.3 V, I _{OH} = 20 mA)	2.5	-	-	V
I _{DD}	Static Supply Current	-	6.0	-	mA
I _{CC}	Dynamic Supply Current (3.3 V and 15 pF loading)	6.0	7.0	8.3	mA
V _{DD}	Operating Voltage	2.7	3.3	3.8	V
t _{ON}	Power Up Time (First locked clock cycle after power up)		0.18		ms
Z _{OUT}	Clock Output Impedance		50		Ω

Table 5. AC ELECTRICAL CHARACTERISTICS

Symbol	Parameter	Min	Typ	Max	Unit
f _{IN}	Input Frequency	10	27	30	MHz
t _{LH} (Note 1)	Output rise time (Measured at 0.8 V to 2.0 V)	0.7	0.9	1.1	ns
t _{HL} (Note 1)	Output fall time (Measured at 0.8 V to 2.0 V)	0.6	0.8	1.0	ns
t _{JC}	Jitter (cycle-to-cycle)	-	-	360	ps
t _D	Output duty cycle	45	50	55	%

1. t_{LH} and t_{HL} are measured into a capacitive load of 15 pF.

P2027A

PACKAGE DIMENSIONS

TSSOP8, 4.4x3
CASE 948AL-01
ISSUE O

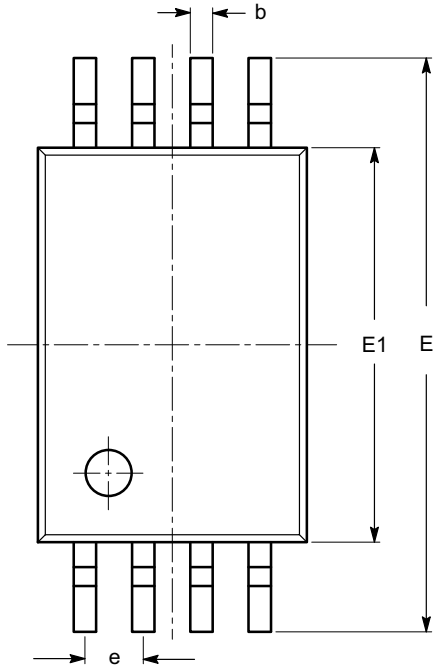

SYMBOL	MIN	NOM	MAX
A			1.20
A1	0.05		0.15
A2	0.80	0.90	1.05
b	0.19		0.30
c	0.09		0.20
D	2.90	3.00	3.10
E	6.30	6.40	6.50
E1	4.30	4.40	4.50
e	0.65 BSC		
L	1.00 REF		
L1	0.50	0.60	0.75
θ	0°		8°

TOP VIEW

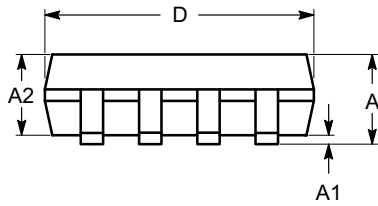

SIDE VIEW

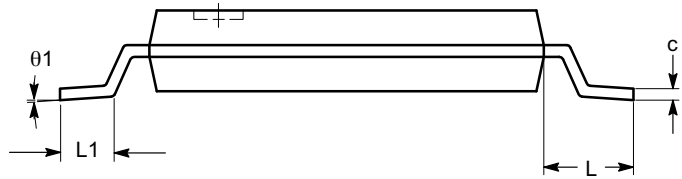

END VIEW

Notes:

- (1) All dimensions are in millimeters. Angles in degrees.
- (2) Complies with JEDEC MO-153.

P2027A

PACKAGE DIMENSIONS

SOIC 8, 150 mils
CASE 751BD-01
ISSUE O

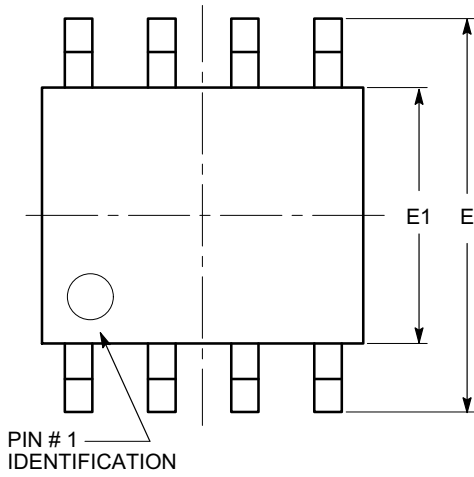

TOP VIEW

SYMBOL	MIN	NOM	MAX
A	1.35		1.75
A1	0.10		0.25
b	0.33		0.51
c	0.19		0.25
D	4.80		5.00
E	5.80		6.20
E1	3.80		4.00
e	1.27 BSC		
h	0.25		0.50
L	0.40		1.27
θ	0°		8°

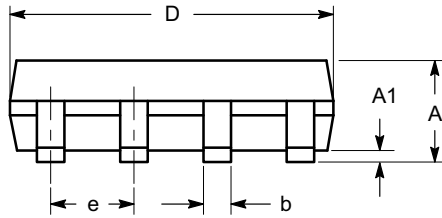

SIDE VIEW

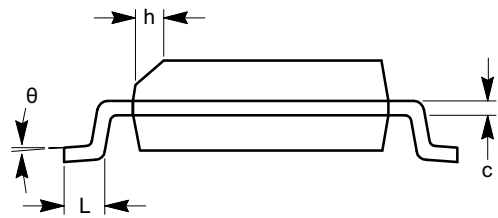

END VIEW

Notes:

- (1) All dimensions are in millimeters. Angles in degrees.
- (2) Complies with JEDEC MS-012.

P2027A

Table 6. ORDERING CODES

Part Number	Marking	Package Type	Temperature
P2027AF-08ST	P2027AF	8-PIN SOIC, TUBE, Pb Free	Commercial
P2027AF-08SR	P2027AF	8-PIN SOIC, TAPE AND REEL, Pb Free	Commercial
P2027AF-08TT	P2027AF	8-PIN TSSOP, TUBE, Pb Free	Commercial
P2027AF-08TR	P2027AF	8-PIN TSSOP, TAPE AND REEL, Pb Free	Commercial
P2027AG-08ST	P2027AG	8-PIN SOIC, TUBE, Green	Commercial
P2027AG-08SR	P2027AG	8-PIN SOIC, TAPE AND REEL, Green	Commercial
P2027AG-08TT	P2027AG	8-PIN TSSOP, TUBE, Green	Commercial
P2027AG-08TR	P2027AG	8-PIN TSSOP, TAPE AND REEL, Green	Commercial

ON Semiconductor and  are registered trademarks of Semiconductor Components Industries, LLC (SCILLC). SCILLC reserves the right to make changes without further notice to any products herein. SCILLC makes no warranty, representation or guarantee regarding the suitability of its products for any particular purpose, nor does SCILLC assume any liability arising out of the application or use of any product or circuit, and specifically disclaims any and all liability, including without limitation special, consequential or incidental damages. "Typical" parameters which may be provided in SCILLC data sheets and/or specifications can and do vary in different applications and actual performance may vary over time. All operating parameters, including "Typicals" must be validated for each customer application by customer's technical experts. SCILLC does not convey any license under its patent rights nor the rights of others. SCILLC products are not designed, intended, or authorized for use as components in systems intended for surgical implant into the body, or other applications intended to support or sustain life, or for any other application in which the failure of the SCILLC product could create a situation where personal injury or death may occur. Should Buyer purchase or use SCILLC products for any such unintended or unauthorized application, Buyer shall indemnify and hold SCILLC and its officers, employees, subsidiaries, affiliates, and distributors harmless against all claims, costs, damages, and expenses, and reasonable attorney fees arising out of, directly or indirectly, any claim of personal injury or death associated with such unintended or unauthorized use, even if such claim alleges that SCILLC was negligent regarding the design or manufacture of the part. SCILLC is an Equal Opportunity/Affirmative Action Employer. This literature is subject to all applicable copyright laws and is not for resale in any manner.

PUBLICATION ORDERING INFORMATION

LITERATURE FULFILLMENT:

Literature Distribution Center for ON Semiconductor
P.O. Box 5163, Denver, Colorado 80217 USA
Phone: 303-675-2175 or 800-344-3860 Toll Free USA/Canada
Fax: 303-675-2176 or 800-344-3867 Toll Free USA/Canada
Email: orderlit@onsemi.com

N. American Technical Support: 800-282-9855 Toll Free
USA/Canada
Europe, Middle East and Africa Technical Support:
Phone: 421 33 790 2910
Japan Customer Focus Center
Phone: 81-3-5773-3850

ON Semiconductor Website: www.onsemi.com

Order Literature: <http://www.onsemi.com/orderlit>

For additional information, please contact your local Sales Representative