

SCP81231

High Resolution Buck Controller with Full USB PD Features and 100% Duty Operation

The SCP81231 is a synchronous buck that is optimized for converting battery voltage or adaptor voltage into power supply rails required in notebook, tablet, and desktop systems, as well as many other consumer devices using USB PD standard and C-Type cables. The SCP81231 is fully compliant to the USB Power Delivery Specification when used in conjunction with a USB PD or C-Type Interface Controller. SCP81231 is designed for applications requiring dynamically controlled slew rate limited output voltage.

Features

- Wide Input Voltage Range: from 4.5 V to 28 V
- Dynamically Programmed Frequency from 150 kHz to 1.2 MHz
- I²C Interface
- Real Time Power Good Indication
- Controlled Slew Rate Voltage Transitioning
- Feedback Pin with Internally Programmed Reference
- High Resolution DAC Voltage
- Two Independent Current Sensing Inputs
- Support Inductor DCR Sensing
- Over Temperature Protection
- Adaptive Non-Overlap Gate Drivers
- Filter Capacitor Switch Control
- 100% Duty Cycle Operation
- Latched Over-Voltage and Over-Current Protection
- Dead Battery Power Support
- 5 x 5 mm QFN32 Package

Typical Application

- Notebooks, Tablets, Desktops
- Gaming
- Monitors, TVs, and Set Top Boxes
- Consumer Electronics
- Car Chargers
- Docking Stations
- Power Banks



ON Semiconductor®

www.onsemi.com

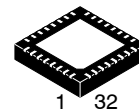

QFN32 5x5, 0.5P
CASE 485CE

MARKING DIAGRAM

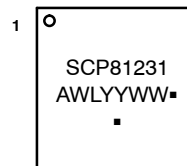

A = Assembly Location
WL = Wafer Lot
YY = Year
WW = Work Week
▪ = Pb-Free Package

(Note: Microdot may be in either location)

ORDERING INFORMATION

Device	Package	Shipping†
SCP81231MNTXG	QFN32 (Pb-Free)	2500 / Tape & Reel

†For information on tape and reel specifications, including part orientation and tape sizes, please refer to our Tape and Reel Packaging Specification Brochure, BRD8011/D.

SCP81231

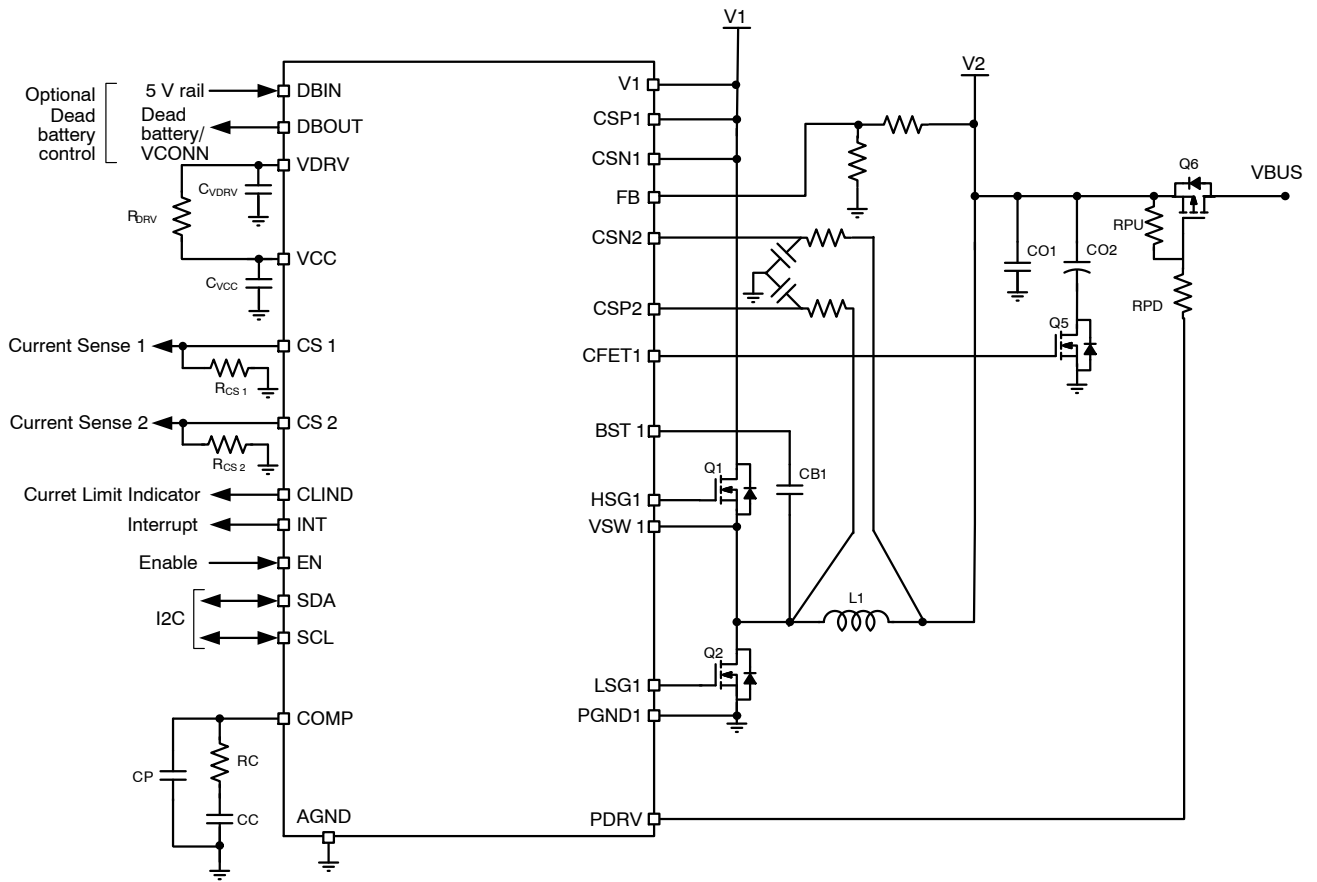

Figure 1. Typical Application Circuit (DCR)

SCP81231

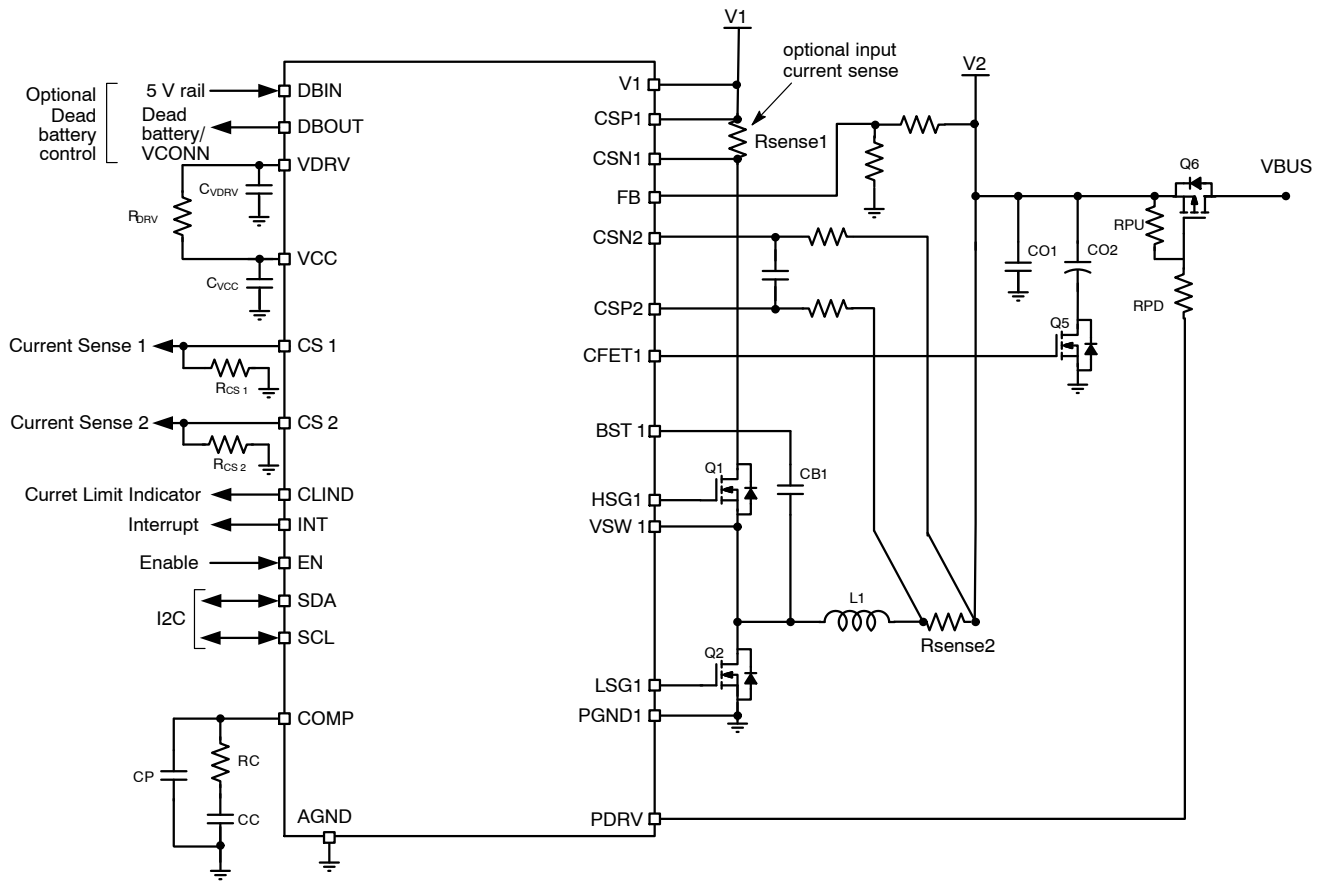

Figure 2. Typical Application Circuit (Rsense)

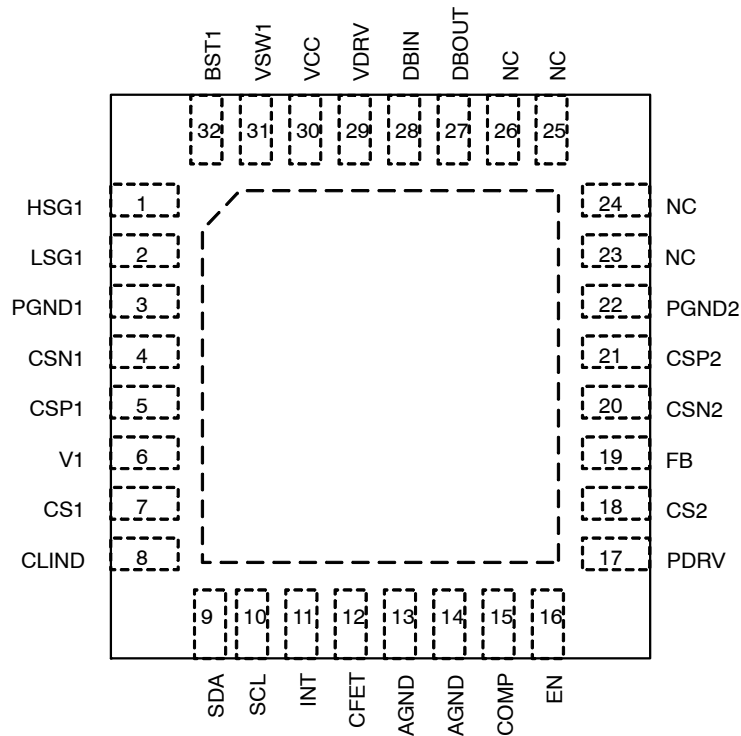

Figure 3. Pinout

SCP81231

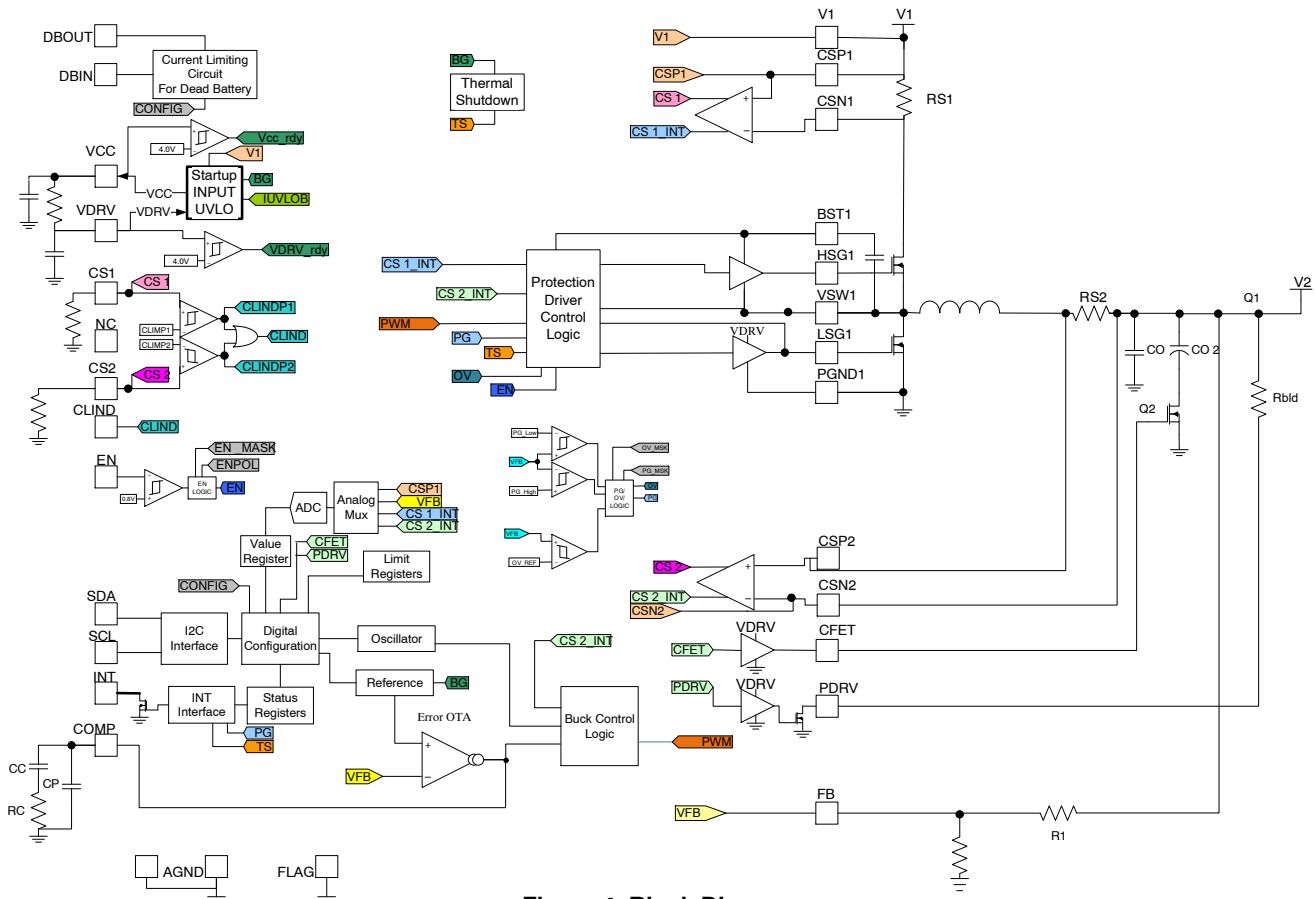

Figure 4. Block Diagram

Table 1. PIN FUNCTION DESCRIPTION

Pin	Pin Name	Description
1	HSG1	S1 gate drive. Drives the S1 N-channel MOSFET with a voltage equal to VDRV superimposed on the switch node voltage VSW1.
2	LSG1	Drives the gate of the S2 N-channel MOSFET between ground and VDRV.
3, 22	PGND	Power ground for the low side MOSFET drivers. Connect these pins closely to the source of the bottom N-channel MOSFETs.
4	CSN1	Negative terminal of the current sense amplifier. Connect it to V1 directly if not used.
5	CSP1	Positive terminal of the current sense amplifier. Connect it to V1 directly if not used.
6	V1	Input voltage of the converter
7	CS1	Current sense amplifier output. CS1 will source a current that is proportional to the voltage across CSP1/CSN1. Connect CS1 to a high impedance monitoring input. Connect it to ground if not used.
8	CLIND	Open drain output to indicate that the CS1 or CS2 voltage has exceeded the I ² C programmed limit. Connect it to ground if not used.
9	SDA	I ² C interface data line.
10	SCL	I ² C interface clock line.
11	INT	Interrupt is an open drain output that indicates the state of the output power, the internal thermal trip, and other I ² C programmable functions.
12	CFET	Controlled drive of an external MOSFET that connects a bulk output capacitor to the output of the power converter. Necessary to adhere to low capacitance limits of the standard USB Specifications for power prior to USB PD negotiation. Connect it to ground if not used.
13, 14	AGND	The ground pin for the analog circuitry.
15	COMP	Output of the transconductance amplifier used for stability in closed loop operation.

SCP81231

Table 1. PIN FUNCTION DESCRIPTION (continued)

Pin	Pin Name	Description
16	EN	Precision enable starts the part and places it into default configuration when toggled.
17	PDRV	The open drain output used to control a PMOSFET or connect to an external resistor. Connect it to ground if not used.
18	CS2	Current sense amplifier output. CS2 will source a current that is proportional to the voltage across CSP1/CSN1. Connect CS2 to a high impedance monitoring input. Connect it to ground if not used.
19	FB	Feedback voltage of the output, negative terminal of the gm amplifier.
20	CSN2	Negative terminal of the current sense amplifier.
21	CSP2	Positive terminal of the current sense amplifier.
23–26	NC	No connection.
27	DBOUT	The output of the dead battery circuit which can also be used for the VCONN voltage supply per USB specs.
28	DBIN	The dead battery input to the converter where 5 V is applied. A 1 μ F capacitor should be placed close to the part to decouple this line.
29	VDRV	Internal voltage supply to the driver circuits. A 1 μ F capacitor should be placed close to the part to decouple this line.
30	VCC	The VCC pin supplies power to the internal circuitry. The VCC is the output of a linear regulator which is powered from V1. Can be used to supply up to a 100 mA load. Pin should be decoupled with a 1 μ F capacitor for stable operation.
31	VSW1	Switch Node. VSW1 pin swings from a diode voltage drop below ground up to V1.
32	BST1	Driver Supply. The BST1 pin swings from a diode voltage below VDRV up to a diode voltage below V1 + VDRV. Place a 0.1 μ F capacitor from this pin to VSW1.
33	THPAD	Center pad, recommended to connect to AGND.

Table 2. MAXIMUM RATINGS

(Over operating free-air temperature range unless otherwise noted)

Rating	Symbol	Min	Max	Unit
Input of the Dead Battery Circuit	DBIN	-0.3	5.5	V
Output of the Dead Battery Circuit	DBOUT	-0.3	5.5	V
Driver Input Voltage	VDRV	-0.3	5.5	V
Internal Regulator Output	VCC	-0.3	5.5	V
Output of Current Sense Amplifiers	CS1, CS2	-0.3	3.0	V
Current Limit Indicator	CLIND	-0.3	VCC + 0.3	V
Interrupt Indicator	INT	-0.3	VCC + 0.3	V
Enable Input	EN	-0.3	5.5	V
I ² C Communication Lines	SDA, SCL	-0.3	VCC + 0.3	V
Compensation Output	COMP	-0.3	VCC + 0.3	V
V1 Power Stage Input Voltage	V1	-0.3	32 V, 40 V (20 ns)	V
Positive Current Sense	CSP1	-0.3	32 V, 40 V (20 ns)	V
Negative Current Sense	CSN1	-0.3	32 V, 40 V (20 ns)	V
Positive Current Sense	CSP2	-0.3	32 V, 40 V (20 ns)	V
Negative Current Sense	CSN2	-0.3	32 V, 40 V (20 ns)	V
Feedback Voltage	FB	-0.3	5.5	V
CFET Driver	CFET	-0.3	VCC + 0.3	V
Driver Positive Rail	BST1	-0.3 V wrt/PGND -0.3 V wrt/VSW	37 V, 40 V (20 ns) wrt/PGND 5.5 V wrt/VSW	V

SCP81231

Table 2. MAXIMUM RATINGS (continued)
(Over operating free-air temperature range unless otherwise noted)

Rating	Symbol	Min	Max	Unit
High Side Driver	HSG1	-0.3 V wrt/PGND -0.3 V wrt/VSW	37 V, 40 V (20 ns) wrt/GND 5.5 V wrt/VSW	V
Switching Node and Return Path of Driver	VSW1	-5.0 V	32 V, 40 V (20 ns)	V
Low Side Driver	LSG1	-0.3 V	5.5	V
PMOSFET Driver	PDRV	-0.3	40	V
Voltage Differential	AGND to PGND	-0.3	0.3	V
CSP1-CSN1, CSP2-CSN2 Differential Voltage	CS1DIF, CS2DIF	-0.5	0.5	V
PDRV Maximum Current	PDRVI	0	10	mA
PDRV Maximum Pulse Current (100 ms on time, with > 1 s interval)	PDRVIPUL	0	200	mA
Maximum VCC Current	VCCI	0	80	mA
Operating Junction Temperature Range (Note 1)	TJ	-40	150	°C
Operating Ambient Temperature Range	TA	-40	100	°C
Storage Temperature Range	TSTG	-55	150	°C
Thermal Characteristics (Note 2) QFN 32 5mm x 5mm	Symbol	Typical Value		Unit
Maximum Power Dissipation @ T _A = 25°C	PD	4.1		W
Thermal Resistance Junction-to-Air with Solder	R θ JA	30		°C/W
Lead Temperature Soldering (10 sec): Reflow (SMD styles only) Pb-Free (Note 3)	RF	260 Peak		°C
ESD Ratings		Min Value		Unit
Human Body Model (Tested per JS-001-2017)		1.5		kV
Charge Device Model (Tested per JS-002-2014)		350		V
Latch-Up (Tested per JESD78E; Class II, Level A, +100°C (T _J))		100		mA

Stresses exceeding those listed in the Maximum Ratings table may damage the device. If any of these limits are exceeded, device functionality should not be assumed, damage may occur and reliability may be affected.

1. The maximum package power dissipation limit must not be exceeded.
2. The value of θ JA is measured with the device mounted on a 3in x 3in, 4 layer, 0.062 inch FR-4 board with 1.5 oz. copper on the top and bottom layers and 0.5 ounce copper on the inner layers, in a still air environment with T_A = 25°C.
3. 60-180 seconds minimum above 237°C.

Table 3. ELECTRICAL CHARACTERISTICS

(V₁ = 12 V, V_{out} = 5.0 V, T_A = +25°C for typical value; -40°C < T_A < 100°C for min/max values unless noted otherwise)

Parameter	Symbol	Test Conditions	Min	Typ	Max	Units
POWER SUPPLY						
V1 Operating Input Voltage	V1		4.5		28	V
VDRV Operating Input Voltage	VDRV		4.5	5	5.5	V
VCC UVLO Rising Threshold	VCC _{START}		4.1	4.25	4.4	V
UVLO Hysteresis for VCC	VCCV _{HYS}	Falling Hysteresis	303	320	332	mV
VDRV UVLO Rising Threshold	VDRV _{START}		4.1	4.25	4.4	V
UVLO Hysteresis for VDRV	VDRV _{HYS}	Falling Hysteresis	318	340	350	mV
VCC Output Voltage	VCC	With no external load	4.96	5	5.25	V
VCC Drop Out Voltage	VCCDROOP	30 mA load (sum of typical IVCC and IVDRV)	90	160	300	mV

SCP81231

Table 3. ELECTRICAL CHARACTERISTICS (continued)

(V1 = 12 V, V_{out} = 5.0 V, T_A = +25°C for typical value; -40°C < T_A < 100°C for min/max values unless noted otherwise)

Parameter	Symbol	Test Conditions	Min	Typ	Max	Units
-----------	--------	-----------------	-----	-----	-----	-------

POWER SUPPLY

VCC Output Current Limit	IOUT _{VCC}	VCC Loaded to 4.3 V	80	100	135	mA
V1 Shutdown Supply Current	IVCC_SD	EN = 0 V, 4.2 V ≤ V1 ≤ 28 V	3.0	6.5	8.0	mA
VDRIVE Switching Current Buck	IV1_SW	EN = 5 V, C _{gate} = 2.2 nF, V _{SW} = 0 V, F _{SW} = 600 kHz	13	15	16	mA

VOLTAGE FEEDBACK

Internal DAC Resolution	VDAC_RES	DAC_TARGET_LSB=0 (default) DAC_TARGET_LSB=1		10 5		mV
Internal DAC number of bits		See the application information		9		bits
Voltage Feedback Accuracy	VFB	DAC_TARGET = 00110010 DAC_TARGET = 01111000 DAC_TARGET = 11001000		0.5 1.2 2.0		V
Voltage Accuracy Over Temperature	VFB_T	-40°C < T _A < 100°C				
		VFB ≥ 0.5 V	-1.0		1.0	%
		VFB < 0.5 V	-5		5	mV
		0°C < T _A < 85°C				
		VFB = 0.5 V	-0.8		0.8	%
		VFB = 0.9 V	-0.8		0.8	%
		VFB = 1.5 V	-0.6		0.6	%
		VFB = 2.05 V	-0.6		0.6	%
	VFB_R	T _A = 25°C VFB ≥ 0.5 V	-0.45		0.45	%

TRANSCONDUCTANCE AMPLIFIER

Gain Bandwidth Product	GBW	3 db (Note 4)	3.6	5.6	7.6	MHz
Transconductance	GM1	Default	400	500	600	μS
Max Output Source Current limit	GMSOC		60	83	95	μA
Max Output Sink Current limit	GMSIC		60	84	100	μA
Voltage Ramp	Vramp		0.56	0.7	0.84	V

INTERNAL BST DIODE

Forward Voltage Drop	VFBOT	I _F = 10 mA, T _A = 25°C	0.35	0.46	0.55	V
Reverse-Bias Leakage Current	DIL	BST-V _{SW} = 5 V V _{SW} = 28 V, T _A = 25°C		0.05	1	μA
BST-V _{SW} UVLO	BST1_UVLO	Rising (Note 4)	3.2	3.5	3.56	V
BST-V _{SW} Hysteresis	BST_HYS	(Note 4)	85	300	400	mV

OSCILLATOR

Oscillator Frequency	FSW_0	FSW = 000, default	560	600	630	kHz
	FSW_1	FSW = 001	132	150	168	kHz
	FSW_7	FSW = 110	1056	1200	1344	kHz
Oscillator Frequency Accuracy	FSWE		-12		12	%
Minimum On Time	MOT	Measured at 10% to 90% of VCC, -40°C < T _A < 100°C		50	100	ns
Minimum Off Time	MOFT	Measured at 90% to 10% of VCC, -40°C < T _A < 100°C	75	90	110	ns

SCP81231

Table 3. ELECTRICAL CHARACTERISTICS (continued)

(V_I = 12 V, V_{out} = 5.0 V, T_A = +25°C for typical value; -40°C < T_A < 100°C for min/max values unless noted otherwise)

Parameter	Symbol	Test Conditions	Min	Typ	Max	Units
-----------	--------	-----------------	-----	-----	-----	-------

INT THRESHOLDS

Interrupt Low Voltage	VINTI	IINT(sink) = 2 mA			0.2	V
Interrupt High Leakage Current	INII	3.3 V		3	100	nA
Interrupt Startup Delay	INTPG	Soft Start end to PG positive edge (INT = PG)		2.1		ms
Interrupt Propagation Delay	PGI	Delay for power good in	3.1	3.3	3.6	ms
	PGO	Delay for power good out	16	100	194	ns
Power Good Threshold (INT = PG)	PGTH	Power Good in from high (falling)	102.9	105	106.6	%
	PGTH	Power Good in from low (rising)	93.3	95	96.3	%
	PGTHYS	PG falling hysteresis	0.3	2.5	4.8	%
FB Overvoltage Threshold	FB_OV		137	140	144	%
Overvoltage Propagation Delay	VFB_OVDL			1 Cycle		

EXTERNAL CURRENT SENSE (CS1,CS2)

Positive Current Measurement High	CS10	CSP1-CSN1 or CSP2-CSN2 = 100 mV	450	500	550	μA
Transconductance Gain Factor	CSGT	Current Sense Transconductance V _{sense} = 1 mV to 100 mV	4	5	6	mS
Transconductance Deviation	CSGE		-20		20	%
Current Sense Common Mode Range	CSCMMR		3		28	V
-3 dB Small Signal Bandwidth	CSBW	VSENSE (AC) = 10 mVPP, RGAIN = 10 kΩ (Note 4)	TBD	0.5		MHz
Input Sense Voltage Full Scale	ISVFS				100	mV
CS Output Voltage Range	CSOR	VSENSE = 100 mV Rset = 6k	0	3	3.3	V

EXTERNAL CURRENT LIMIT (CLIND)

Current Limit Indicator Output Low	CLINDL	Input current = 500 μA		10	100	mV
Current Limit Indicator Output High Leakage Current	ICLINDH	Pull up to 5 V		3	100	nA

INTERNAL CURRENT SENSE

Internal Current Sense Gain for PWM	ICG	CSPx-CSNx = 100 mV	9.2	9.9	10.5	V/V
Positive Peak Current Limit Trip	PPCLT	INT_CL = 00	34	39	44	mV

SWITCHING MOSFET DRIVERS

HSG Pullup Resistance	HSG_PU	HSG-VSW = 5 V, source current = 80 mA	1.8	2.9	4.2	Ω
HSG Pulldown Resistance	HSG_PD	HSG-VSW = 5 V, sink current = 80 mA	0.8	1.3	1.8	Ω
LSG Pullup Resistance	LSG_PU	LSG-PGND = 5 V, source current = 80 mA	2.3	3.4	4.3	Ω
LSG Pulldown Resistance	LSG_PD	LSG-PGND = 5 V, sink current = 80 mA	0.7	1.1	1.3	Ω
HSG Falling to LSG Rising Delay	HSLSD	open circuit with 3.3 nF load, from HSG = 0.5 V to LSG = 0.5 V	13	18	25	ns
LSG Falling to HSG Rising Delay	LSHSD	open circuit with 3.3 nF load, from LSG = 0.5 V to HSG = 0.5 V	38	45	51	ns

SCP81231

Table 3. ELECTRICAL CHARACTERISTICS (continued)

(V_I = 12 V, V_{out} = 5.0 V, T_A = +25°C for typical value; -40°C < T_A < 100°C for min/max values unless noted otherwise)

Parameter	Symbol	Test Conditions	Min	Typ	Max	Units
-----------	--------	-----------------	-----	-----	-----	-------

CFET

CFET Drive Voltage	CFETDV		4.95	5	5.25	V
Source/Sink Current	CFETSS	CFET clamped to 2 V	1.5	2	2.5	μA
Pull Down Delay	CFETD	Measured at 10% to 90% of VCC, -40°C < T _A < 100°C	9	10	11	ms
CFET Pull Down Resistance	CFETR	Measured with 1 mA Pull up Current, after 10 ms rising edge delay	1.2	1.3	1.4	kΩ

SLEW RATE/SOFT START

Charge Slew Rate	SLEWP	Slew = 00, FB = 0.1 VOUT Slew = 11, FB = 0.1 VOUT	0.57 4.56	0.6 4.8	0.65 5.15	mV/μs
Discharge Slew Rate	SLEWN	Slew = 00, FB = 0.1 VOUT Slew = 11, FB = 0.1 VOUT	-0.64 -5.15	-0.6 -4.8	-0.57 -4.56	mV/μs

DEAD BATTERY/VCONN

Dead Battery Input Voltage Range	VDB		4.5	5	5.25	V
Dead Battery Output Voltage	VIO	VDB = 5 V, -40°C < T _A < 100°C, Output Current 32 mA	4	4.7	5	V
Dead Battery Current Limit	DB_LIM	VDB = 5 V, DBOU _T > 2 V	29	57	77	mA

ENABLE

EN High Threshold Voltage	ENHT	EN_MASK = ENPU = ENPOL = 0	780	800	820	mV
EN Low Threshold Voltage	ENLT		640	667	686	mV
EN Pull Up Current	IEN_UP	EN = 0 V	4.3	5	5.7	μA
EN Pull Down Current	IEN_DN	EN = VCC	4.3	5	5.6	μA

I²C INTERFACE

Voltage Threshold	I2CVTH		0.95	1	1.05	V
Propagation Delay	I2CPD	(Note 4)		25		ns
Communication Speed	I2CSP	(Note 4)			1	MHz

INTERNAL ADC

Range	ADCRN		0		2.55	V
LSB Value	ADCLSB	(Note 4)		20		mV
Error	ADCFE	(Note 4)			1	LSB

THERMAL SHUTDOWN

Thermal Shutdown Threshold	TSD	(Note 4)		151		°C
Thermal Shutdown Hysteresis	TSDHYS	(Note 4)		28		°C

PDRV

PDRV Operating Range			0		28	V
PDRV Leakage Current	PDRV_IDS	FET OFF, VPDRV = 28 V		480		nA
PDRV Saturation Voltage	PDRV_VDS	ISNK = 10 mA		0.20		V

Product parametric performance is indicated in the Electrical Characteristics for the listed test conditions, unless otherwise noted. Product performance may not be indicated by the Electrical Characteristics if operated under different conditions.

4. Ensured by design. Not production tested.

APPLICATION INFORMATION

Feedback and Output Voltage Profile

The feedback of the converter output voltage is connected to the FB pin of the device through a resistor divider. Internally FB is connected to the inverting input of the internal transconductance error amplifier. The non-inverting input of the gm amplifier is connected to the internal reference. The internal reference voltage is generated by a 9-bit DAC. Its LSB is named `dac_target_lsb` in the address of 03h, bit[4]. The register of the upper 8 bits is named `dac_target` in the address of 01h. Please refer to Table 18 for the I2C register map details. When the `dac_target_lsb` is used, the resolution of the reference voltage is 5 mV. Otherwise, the resolution is 10 mV. The internal reference voltage is by default 0.5 V. Therefore, for example, a 10:1

resistor divider from the converter output to the FB will set the output voltage to 5 V in default. The reference voltage can be adjusted with 10 mV (default) or 5 mV steps from 0.3 V to 2.55 V through the voltage profile register (01H), which makes the continuous output voltage profile possible through an external resistor divider. For example, if the external resistor divider has a 10:1 ratio, the output voltage profile will be able to vary from 3 V to 25.5 V with 100 mV steps but not above V1 voltage.

NOTE: for reserved DAC voltage setting, please see issue #2 in Radar #40143801 X1337 NCP81231: Errata Update 032719.pptx

Table 4. VOLTAGE PROFILE SETTINGS

dac_taget (01h)								dac_target_LSB (03h, bit [4])	dac_taget (01h) Hex Value	Reference Voltage (mV)
bit_8	bit_7	bit_6	bit_5	bit_4	bit_3	bit_2	bit_1			
0	0	0	0	0	0	0	0	0	00H	Reserved
0	0	0	0	0	0	0	0	1	00H	Reserved
0	0	0	0	0	0	0	1	0	01H	Reserved
...
0	0	0	1	1	1	0	1	1	1DH	Reserved
0	0	0	1	1	1	1	0	0	1EH	300
0	0	0	1	1	1	1	0	1	1EH	305
...
0	0	1	1	0	0	1	0	0	32H	500 (Default)
...
1	1	0	0	1	0	0	0	0	C8H	2000
...
1	1	1	1	1	1	1	1	0	FFH	2550
1	1	1	1	1	1	1	1	1	FFH	2555

TYPICAL CHARACTERISTICS

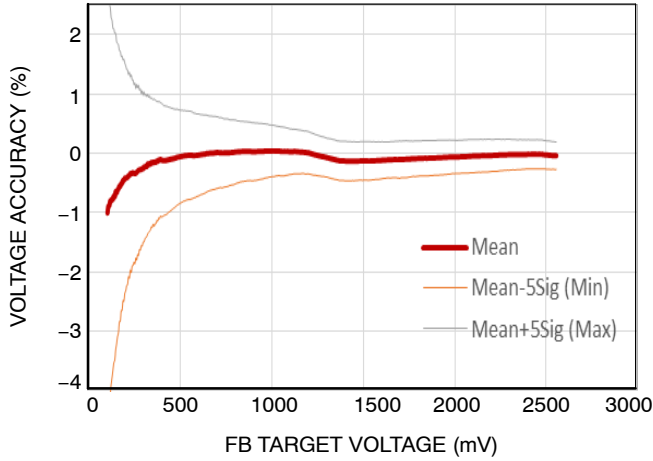

Figure 5. Reference Voltage Accuracy at Temperature -40°C

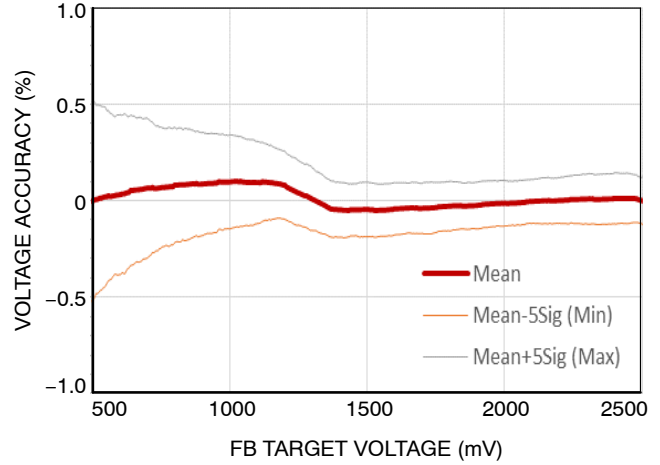

Figure 6. Reference Voltage Accuracy at Temperature 0°C

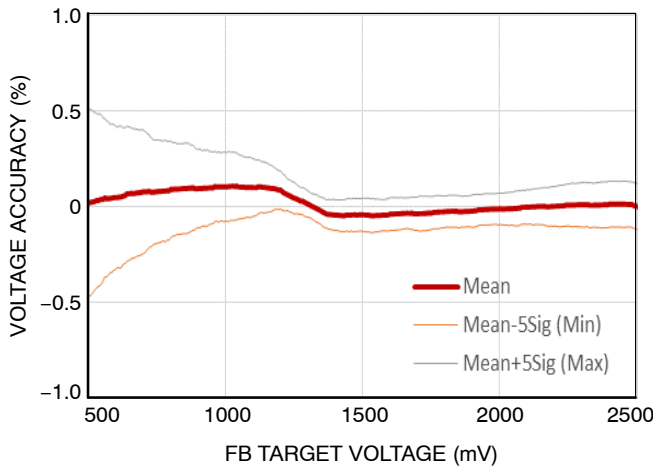

Figure 7. Reference Voltage Accuracy at Temperature 25°C

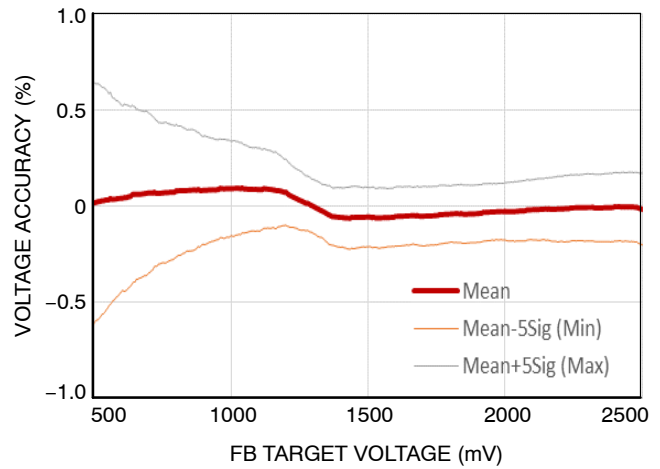

Figure 8. Reference Voltage Accuracy at Temperature 55°C

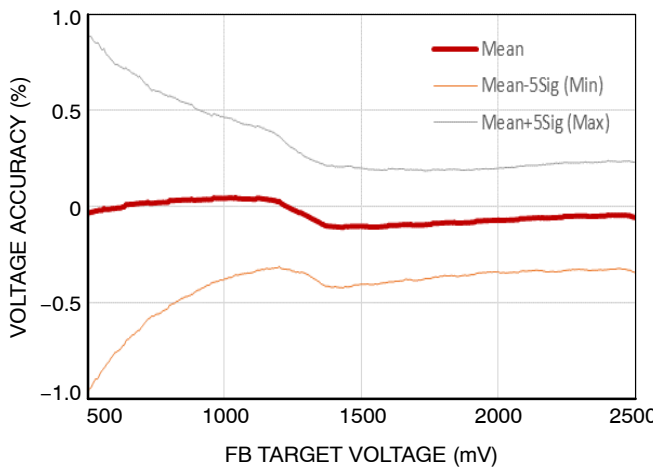

Figure 9. Reference Voltage Accuracy at Temperature 85°C

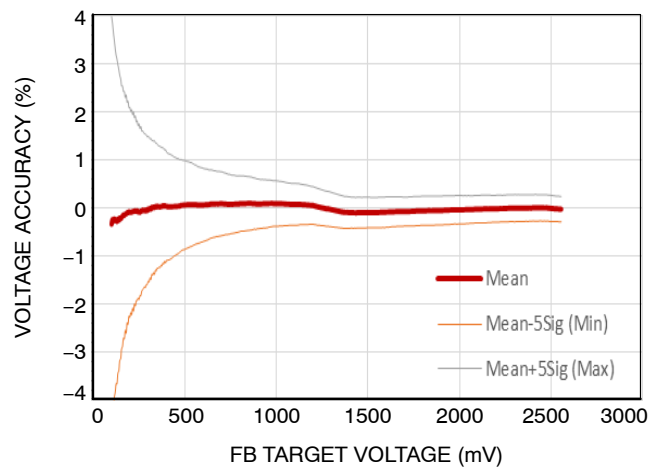

Figure 10. Reference Voltage Accuracy at Temperature 105°C

SCP81231

Transconductance Voltage Error Amplifier

To maintain loop stability under a large change in capacitance, the SCP81231 can change the gm of the internal transconductance error amplifier from 87 μS to

1000 μS allowing the DC gain of the system to be increased more than a decade triggered by the adding and removal of the bulk capacitance or in response to another user input. The default transconductance is 500 μS .

Table 5. AVAILABLE TRANSCONDUCTANCE SETTING

AMP_2	AMP_1	AMP_0	Amplifier GM Value (μS)
0	0	0	87
0	0	1	100
0	1	0	117
0	1	1	333
1	0	0	400
1	0	1	500
1	1	0	667
1	1	1	1000

Programmable Slew Rate

The slew rate of the SCP81231 is controlled via the I²C registers with the default slew rate set to 0.6 mV/ μS (FB = 0.1 VOUT, assume the resistor divider ratio is 10:1) which is the slowest allowable rate change. The slew rate is used when the output voltage starts from 0 V to a user selected profile level, changing from one profile to another, or when the output voltage is dynamically changed. The output voltage is divided by a factor of the external resistor divider and connected to FB pin. The 9 Bit DAC is used to increase the reference voltage in 10 or 5 mV increments. The

slew rate is decreased by using a slower clock that results in a longer time between voltage steps, and conversely increases by using a faster clock. The step monotonicity depends on the bandwidth of the converter where a low bandwidth will result in a slower slew rate than the selected value. The available slew rates are shown in Table 6. The selected slew rate is maintained unless the current limit is tripped, in which case the increased voltage will be governed by the positive current limit until the output voltage falls or the fault is cleared.

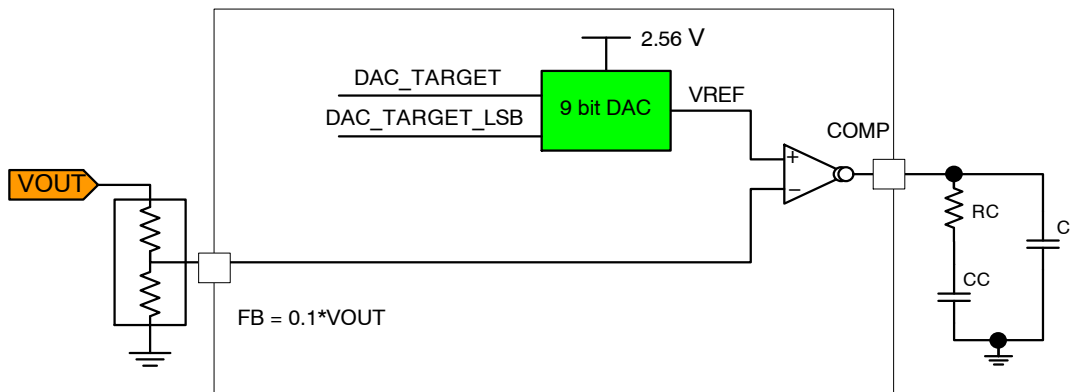

Figure 11. Slew Rate Limiting Block Diagram and Waveforms

Table 6. SLEW RATE SELECTION

Slew Bits	Soft Start or Voltage Transition (FB = 0.1*VOUT)
Slew_0	0.6 mV/ μS
Slew_1	1.2 mV/ μS
Slew_2	2.4 mV/ μS
Slew_3	4.8 mV/ μS

The discharge slew rate is accomplished in much the same way as the charging except the reference voltage is decreased rather than increased.

Soft Start

During a 0 V soft start, standard converters can start in synchronous mode and have a monotonic rising of output voltage. If a prebias exists on the output and the converter starts in synchronous mode, the prebias voltage will be discharged. The SCP81231 controller ensures that if a prebias is detected, the soft start is completed in a

non-synchronous mode to prevent the output from discharging.

It takes at least 3.3 ms for the digital core to reset all the registers, so it is recommended not to restart a soft start until at least 3.3 ms after the output voltage ramp down to steady state.

Frequency Programming

The switching frequency of the SCP81231 can be programmed from 150 kHz to 1.2 MHz via the I²C interface. The default switching frequency is set to 600 kHz. Once the part is enabled, the frequency is set and cannot be changed while the part remains enabled. The part must be disabled with no switching prior to writing the frequency bits into the appropriate I²C register.

Table 7. FREQUENCY PROGRAMMING TABLE

Name	Bit	Definition	Description
Freq1	03H [2:0]	Frequency Setting	3 Bits that Control the Switching Frequency from 150 kHz to 1.2 MHz. 000: 600 kHz (default) 001: 150 kHz 010: 300 kHz 011: 450 kHz 100: 750 kHz 101: 900 kHz 110: 1.2 MHz 111: Reserved

100% Duty Cycle Operation

SCP81231 can operate in a 100% duty cycle mode when the high side switch works as a bypass switch. A detection circuit will constantly monitor the high side gate voltage and turn on the low side switch to charge/refresh the bootstrap capacitor only when the voltage across the bootstrap capacitor is below the BST_UVLO voltage. Therefore the switching frequency is no longer determined by the clock but adaptively decrease to several kilo hertz. When the system stays in the 100% duty cycle operation, the output will always follow the input regardless the COMP voltage and COMP is likely to creep up. If a fast COMP recovery is required, the following clamping circuitry can be considered with a larger than 1.5 V clamping voltage set as the target.

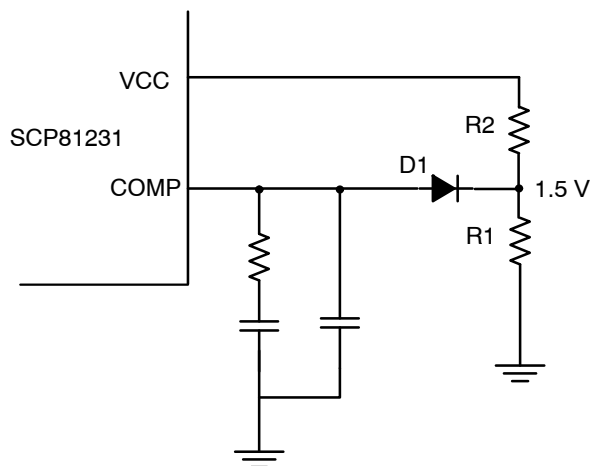

Figure 12. External Comp Clamping Circuit

Current Sense Amplifiers

Internal differential amplifiers measure the potential between the terminal CSP1/CSN1 or CSP2/CSN2. The potential difference between CSP_x and CSN_x is level shifted from the high voltage domain to the low voltage VCC domain.

SCP81231 can experience latent shifts in the internal current sense gain for PWM (ICG) after prolonged exposure to high temperatures. Typically, the internal current sense gain for PWM amplify the level shifted current sense signals from CSP2 and CSN2 by 10 times and send it to the over current protection comparator and the PWM generator. It is shown in Figure 14. However, this gain can shift to 8 V/V after extended exposure to high temperature when EN is low.

NOTE: See Radar #40143801 X1337 NCP81231: Errata Update 032719.pptx

To avoid this issue, it is recommended to avoid having a prebias voltage > 4 V on the output at high temperature while EN is low and V1 is powered.

Since this gain shift can affect the control loop, so please leave enough loop gain and phase margin in designing the control loop.

Both current sense signals can be monitored externally by CS1 and CS2 pins. They are fixed gm amplifier outputs, allowing users to set output gain by shunting resistors. CS1 correlates to the CSP1/CSN1 reading, CS2 correlates to the CSP2/CSN2 reading. When not used, CSP1/CSN1 pin can be shorted therefore CS1 reading is omitted.

SCP81231 also uses CSP2/CSN2 current sense signal for current mode modulation and cycle by cycle positive and negative peak current limiting. The inputs of CSP2/CSN2 can be a current sense resistor or configured for inductor DCR sensing shown as Figure 15. A resistor Rs1 connects from switch node to CSP2 and Rs2 connects from the output voltage to CSN2 respectively. Two capacitors, Cs1 and Cs2, are common mode filtering capacitors from CSP2 and CSN2 to the ground. Choose Rs1=Rs2=Rs, Cs1=Cs2=C_s; In order to replicate inductor current sensing information, Rs*C_s needs to be equal or slightly higher than the ratio of output inductance over its DC resistance or L/DCR. Additional resistor network may be added to expand the actual current limit tripping range.

SCP81231

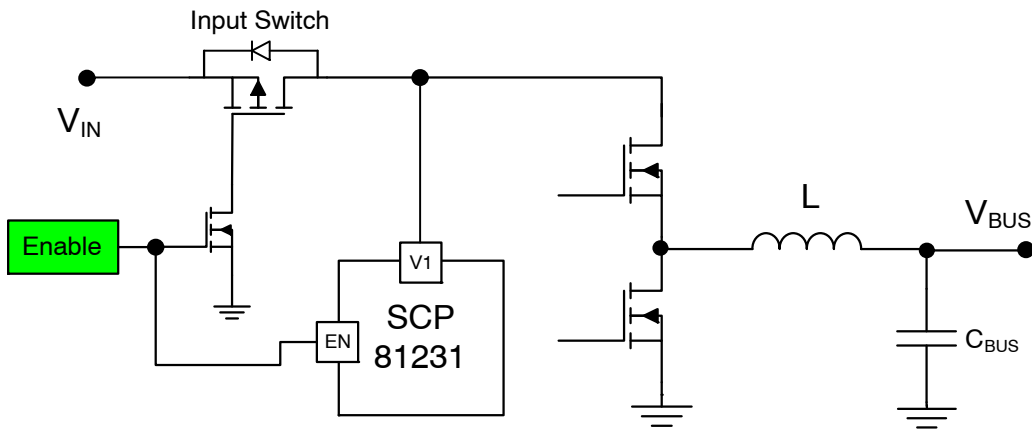

Figure 13. Input Switch Circuit to Disconnect V1 when EN is Low

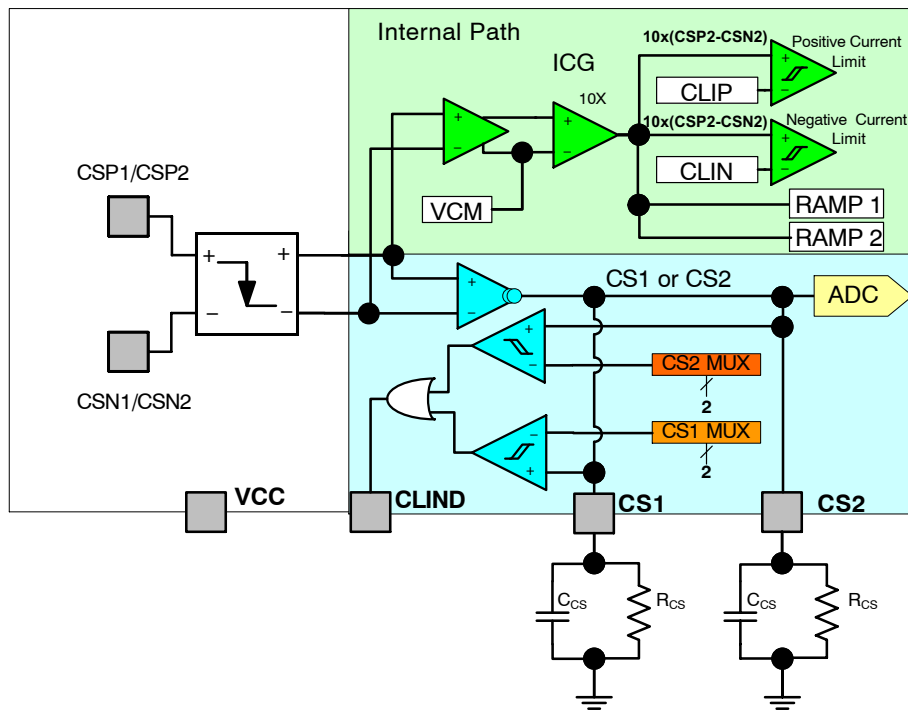

Figure 14. Block Diagram for Current Sense Channel

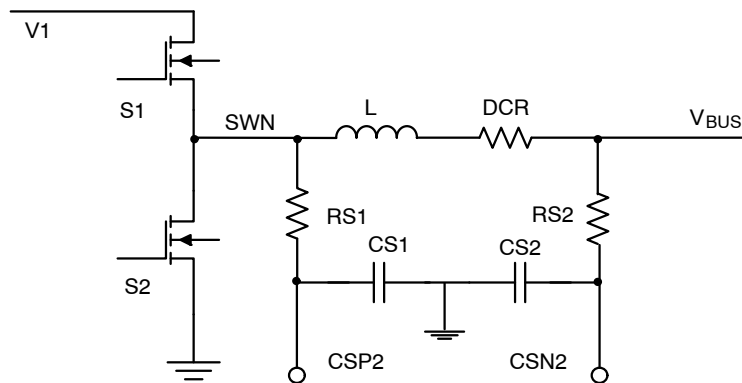

Figure 15. Inductor DCR Sensing Using CSP2/CSN2

Positive Current Limit Internal Path

The SCP81231 has a pulse by pulse current limiting function activated when a positive current limit triggers. When a positive current limit is triggered, the current pulse is truncated. For SCP81231, the CSP2/CSN2 pins will be the positive current limit sense channel.

The S1 switch is turned off to limit the energy during an over current event. The current limit is reset every switching cycle and waits for the next positive current limit trigger. In

this way, current is limited on a pulse by pulse basis. Pulse by pulse current limiting is advantageous for limiting energy into a load in over current situations but are not up to the task of limiting energy into a low impedance short. To address the low impedance short, the SCP81231 will go to latch up mode if pulse by pulse current limiting continues for more than 4 cycles. Toggling the enable pin or resetting the input voltage (V1) will clear the latched OCP fault.

Table 8. INTERNAL PEAK CURRENT LIMIT

CLIP_1	CLIP_0	CSP2–CSN2 (mV)	Trip Current at RSENSE = 5 mΩ (A)	Trip Current at RSENSE = 10 mΩ (A)
0	0	38	7.6	3.8
0	1	23	4.6	2.3
1	0	11	2.2	1.1
1	1	70	14	7

External Path (CS1, CS2, CLIND)

The voltage drop across CSP1/CSN1 or CSP2/CSN2 as a result of the load can be observed on the CS1 and CS2 pins. The voltage drop is converted into a current by a transconductance amplifier with a typical GM of 5 mS. The final gain of the output is determined by the end users selection of the R_{CS} resistors or the inductor DCR resistor. The output voltage of the CS pin can be calculated from Equation 1. The user must be careful to keep the dynamic range below 3.0 V when considering the maximum short circuit current.

$$V_{CS} = (I_{LOAD_MAX} * R_{SENSE} * Trans) * R_{CS} \rightarrow$$

$$\rightarrow 2.967 \text{ V} = (8.5 \text{ A} * 5 \text{ m}\Omega * 5 \text{ mS}) * 13.96 \text{ k}\Omega$$

$$R_{CS} = \frac{V_{CS}}{I_{LOAD} * R_{SENSE} * Trans} \rightarrow$$

$$\rightarrow 13.96 \text{ k}\Omega = \frac{2.967 \text{ V}}{8.5 \text{ A} * 5 \text{ m}\Omega * 5 \text{ mS}} \quad (\text{eq. 1})$$

The speed and accuracy of the dual amplifier stage allows the reconstruction of the input and output current signal, creating the ability to limit the peak current. If the user would like to limit the mean DC current of the switch, a capacitor can be placed in parallel with the R_{CS} resistors.

The external CS voltages are connected to 2 high speed low offset comparators. The comparators output can be used to suspend operation until reset or restart of the part depending on I²C configuration. When one of the comparators trips if not masked, the external CLIND flag is triggered to indicate that the internal comparator has exceeded the preset limit. The default comparator setting is 250 mV which is a limit of 500 mA with a current sense resistor of 5 mΩ and an R_{CS} resistor of 20 kΩ. The block diagram in Figure 16 shows the programmable comparators and the settings are shown in Table 9.

CLIND may misbehave when EN toggles. It is because the internal analog circuit is not fully functional when EN is just asserted. One solution is to force the CLIND low during EN is low and release CLIND after certain time after EN goes high.

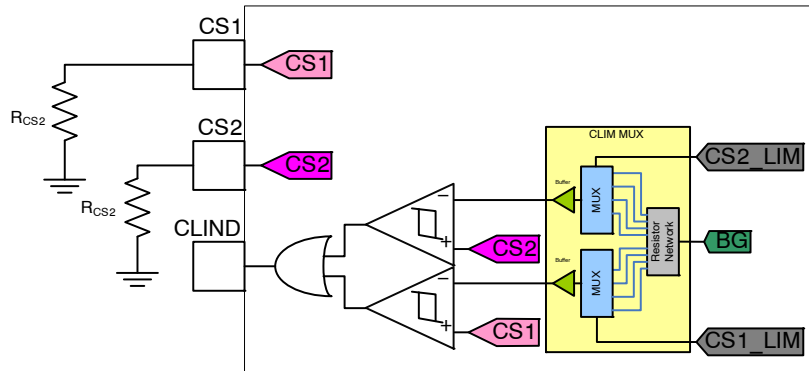

Figure 16. Block Diagram for CLIM Comparator

Table 9. REGISTER SETTING FOR THE CLIM COMPARATORS

CLIMx_1	CLIMx_0	CSx_LIM (V)	Current at RSENSE = 5 mΩ Rcs = 10 kΩ (A)	Current at RSENSE = 10 mΩ Rcs = 10 kΩ (A)
0	0	0.25	1	0.5
0	1	0.75	3	1.5
1	0	1.5	6	3
1	1	2.5	10	5

Overvoltage Protection (OVP)

When the divided output voltage is 40% (typical) above the internal reference voltage, a latched OV fault will be triggered by default, where both the high side and low side switch will be driven off.

There is a one-time-programmable fuse option to change the behavior of OVP operation from a latched shutdown to a hiccup mode to bring the voltage down to normal level and reengage into normal operations. In this mode, once an OVP is detected, S2 is on and S1 is off for the overvoltage recovery process (as the impedance of the input voltage supply is unknown and as such it is not advisable to transfer energy from the output to the input as this will serve to boost the voltage of the input). This allows the current in the inductor to ramp down and discharge the output until S2 turns off when the voltage falls into the power good range. Please be noted that the inductor current is not regulated but continue to increase in the negative direction, therefore the current amplitude can be very high. Once power is good, the COMP pin is released (COMP is clamped at 0.5 V during OVP to avoid loop run away) and the controller will resume normal operation.

When the reference voltage is close to 0 V, it's easy to trigger OVP falsely. So one should avoid using output voltage profile under 0.3 V for safety in normal operation. When 0 V output voltage is needed, one can disable SCP81231 by pulling EN pin down, instead of setting output voltage profile to 0 via I2C. Toggling the enable pin will not clear the latched OVP fault. Only resetting the input voltage (V1) can clear it.

Power Good Monitor (PG)

SCP81231 provides two window comparators to monitor the internal feedback voltage. The target voltage window is ±5% of the reference voltage (typical). Once the feedback voltage is within the power good window, a power good indication is asserted once a 3.3 ms timer has expired. If the feedback voltage falls outside a ±8% window for greater than 1 switching cycle, the power good register is reset. Power good is indicated on the INT pin if the related I²C register is set to display the PG state. During startup, INT is set until the feedback voltage is within the specified range for 3.3 ms.

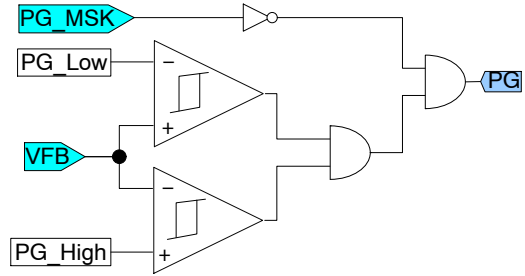

Figure 17. PG Block Diagram

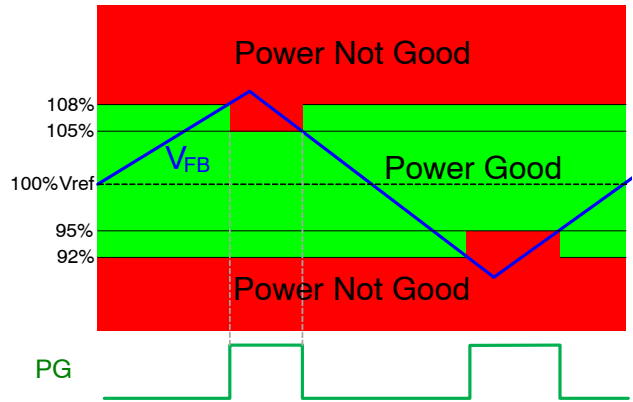

Figure 18. PG Diagram

Table 10. POWER GOOD MASKING

PG_MSK	Description
0	PG Action and Indication Unmasked
1	PG Action and Indication Masked

Thermal Shutdown

The SCP81231 protects itself from overheating with an internal thermal shutdown circuit. If the junction temperature exceeds the thermal shutdown threshold (typically 150°C), all MOSFETs will be driven to the off state, and the part will wait until the temperature decreases to an acceptable level. The fault will be reported to the fault register and the INT flag will be set unless it is masked.

SCP81231

When the junction temperature drops below 125°C (typical), the part will discharge the output voltage to 0 V.

CFET Turn On

The CFET is used to engage the output bulk capacitance after successful negotiations between a consumer and a provider. The USB Power Delivery Specification requires that no more than 30 μF of capacitance be present on the VBUS rail when sinking power. Once the consumer and provider have completed a power role swap, a larger capacitance can be added to the output rail to accommodate a higher power level. The bulk capacitance must be added in

such a way as to minimize current draw and reduce the voltage perturbation of the bus voltage. The SCP81231 incorporates a right drive circuit that regulates current into the gate of the MOSFET such that the MOSFET turns on slowly reducing the drain to source resistance gradually. Once the transition from high to low has occurred in a controlled way, a strong pulldown driver is used to ensure normal operation does not turn on the power N-MOSFET engaging the bulk capacitance. The CFET must be activated through the I²C interface where it can be engaged and disengaged. The default state is to have the CFET disengaged.

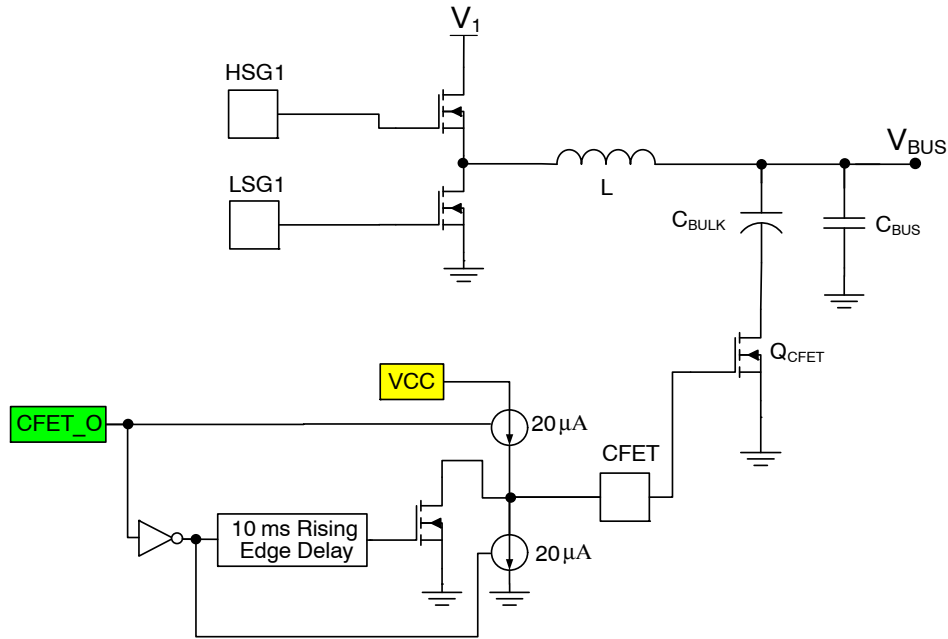

Figure 19. CFET Drive

Table 11. CFET ACTIVATION TABLE

CFET_0	Description
0	CFET Pin Pulldown
1	CFET Pin Pull Up

PFET Drive

The PMOS drive is an open drain output used to control the turn on and turn off of PMOSFET switches at a floating potential or to create an external discharging path. The RDSon of the pulldown NMOSFET is typically 20 Ω allowing the user to quickly turn on for a fast output discharge or to control the external pass FETs.

Table 12. PFET ACTIVATION TABLE

PFET_DRV	Description
0	NFET OFF (Default)
1	NFET ON

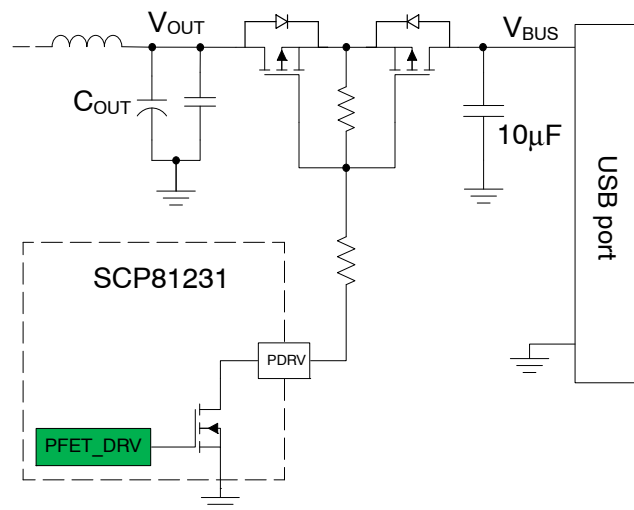

Figure 20. PFET Drive

SCP81231

Analog to Digital Converter

The analog to digital converter is a 7-bit A/D which can be used as an event recorder, an input voltage sampler, output voltage sampler, input current sampler, or output current sampler. The converter digitizes real time data during the sample period. The internal precision reference is used to provide the full range voltage; in the case of input voltage V1 or the feedback voltage FB (with 10:1 external resistor divider) the full range is 0 V to 25.5 V. V1 is internally divided down by 10 before it is digitized by the

ADC, thus the range of the measurement is 0 V–2.55 V, same as FB. The resolution of the V1 and FB voltage is 20 mV at the analog mux, but since the voltage is divided by 10 output voltage resolution will be 200 mV. When CS1 and CS2 are sampled, the range is 0 V–2.55 V. The resolution will be 20 mV in the CS monitoring case. The actual current can be calculated by dividing the CS1 or CS2 values with the factor of $R_{sense} * 5mS * RCSx$, the total gain from the current input to the external current monitoring outputs.

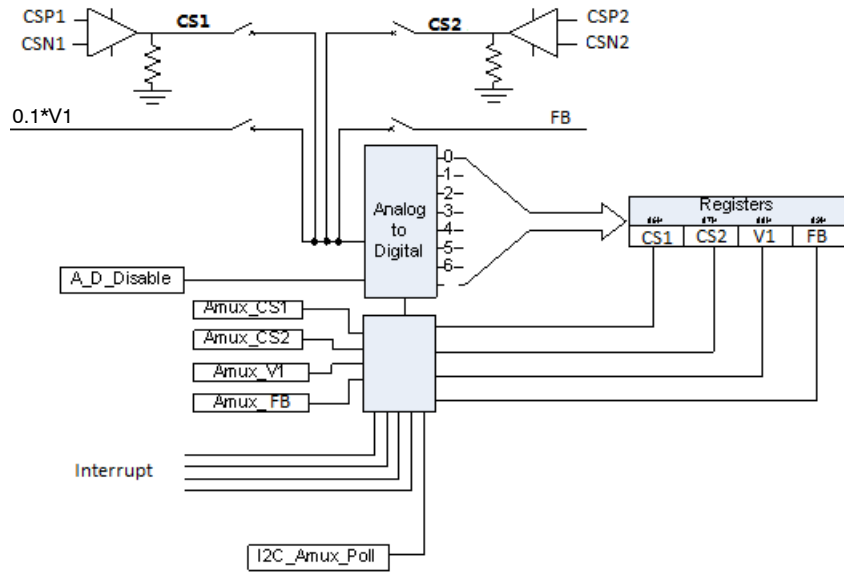

Figure 21. Analog to Digital Converter

Table 13. ADC BYTE

	MSB	5	4	3	2	1	LSB
DATA	D6	D5	D4	D3	D2	D1	D0

Table 14. REGISTER SETTING FOR ENABLING DESIRED ADC BEHAVIOUR

ADC_1	ADC_0	Description
0	0	Sets Amux to VFB
0	1	Sets Amux to V1
1	0	Sets Amux to CS2
1	1	Sets Amux to CS1

Table 15. REGISTER SETTING FOR ADC TRIGGER MANNER

ADC Trigger	Description
00	Trigger a 1xread by a fault condition (Default)
01	Trigger a 1xread
10	Trigger a continuous read

Interrupt Control

The interrupt controller continuously monitors internal interrupt sources, generating an interrupt signal when a system status change is detected. Individual bits generating interrupts will be set to 1 in the INTACK register (I²C read only registers), indicating the interrupt source. All interrupt sources can be masked by writing 1 in register INTMSK. Masked sources will never generate an interrupt request on the INT pin. The INT pin is an open drain output. A non-masked interrupt request will result in the INT pin being driven high. Figure 22 illustrates the interrupt process.

The interrupt source registers (14h,15h) always read 0 when any interrupt happens. The solution is to first keep Int_mask_XXX registers (09h) low by default. INT can toggle after any fault happens. Then set int_mask_XXX registers to high, it will flag the corresponding interrupt source registers if the fault is still there. Now the interrupt source registers can be read. In the end, set int_mask_XXX registers to low again after reading interrupt status registers.

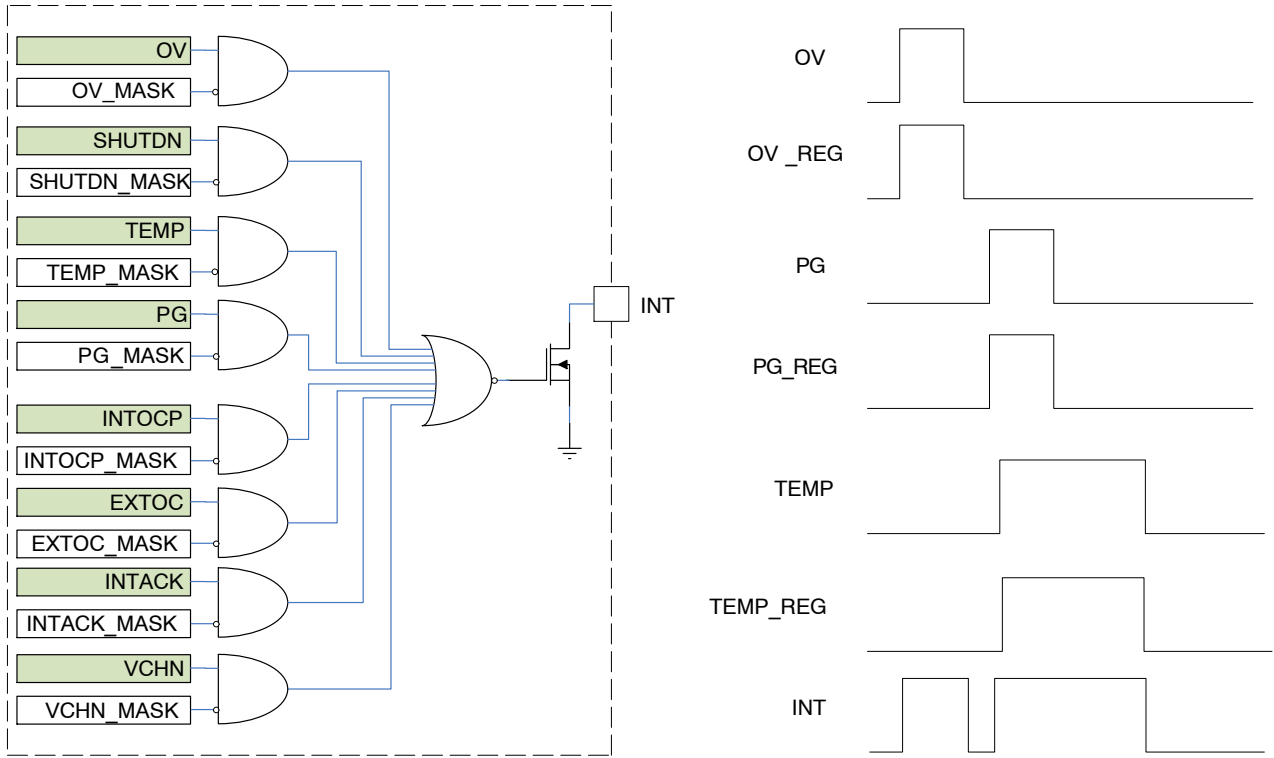

Figure 22. Interrupt Logic

Table 16. INTERPRETATION TABLE

Interrupt Name	Description
OV	Output Over Voltage
Shutdown	Shutdown Detection (EN=low)
TEMP	IC Thermal Trip
PG	Power Good Trip Thresholds Exceeded
INTOCP	Internal Current Limit Trip
EXTOC	External Current Trip from CLIND
VCHN	Output Negative Voltage Change
INTACK	I ² C ACK signal to the host

I²C Address

The default address is set to 77h.

Table 17. I²C ADDRESS

I ² C Address	Hex	A6	A5	A4	A3	A2	A1	A0
ADD0 (default)	0x77	1	1	1	0	1	1	1

SCP81231

I²C interface

The I²C interface can support 5 V TTL, LVTTTL, 2.5 V and 1.8 V interfaces with two precision SCL and SDA comparators with 1V thresholds shown in Figure 23. The part cannot support 5 V CMOS levels as there can be some ambiguity in voltage levels.

I²C Compatible Interface

The SCP81231 can support a subset of I²C protocol as detailed below. The SCP81231 communicates with the

external processor by means of a serial link using a 400 kHz up to 1.2 MHz I²C two-wire interface protocol. The I²C interface provided is fully compatible with the Standard, Fast, and High-Speed I²C modes. The SCP81231 is not intended to operate as a master controller; it is under the control of the main controller (master device), which controls the clock (pin SCL) and the read or write operations through SDA. The I²C bus is an addressable interface (7-bit addressing only) featuring two Read/Write addresses.

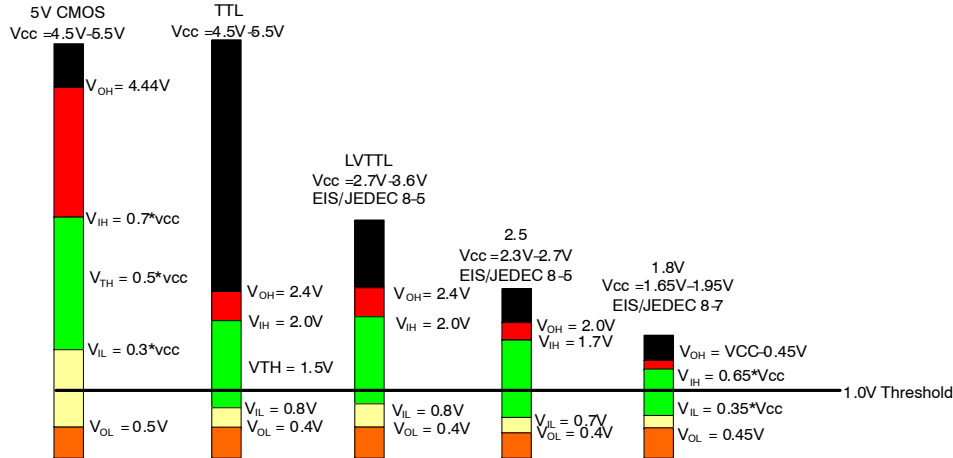

Figure 23. I²C Thresholds and Comparator Thresholds

I²C Communication Description

The first byte transmitted is the chip address (with the LSB bit set to 1 for a Read operation, or set to 0 for a Write operation). Following the 1 or 0, the data will be:

- In case of a Write operation, the register address (@REG) pointing to the register for which it will be written is followed by the data that will be written in that location. The writing process is auto-incremental, so

the first data will be written in @REG, the contents of @REG are incremented, and the next data byte is placed in the location pointed to @REG + 1 ..., etc.

- In case of a Read operation, the SCP81231 will output the data from the last register that has been accessed by the last write operation. Like the writing process, the reading process is auto-incremental.

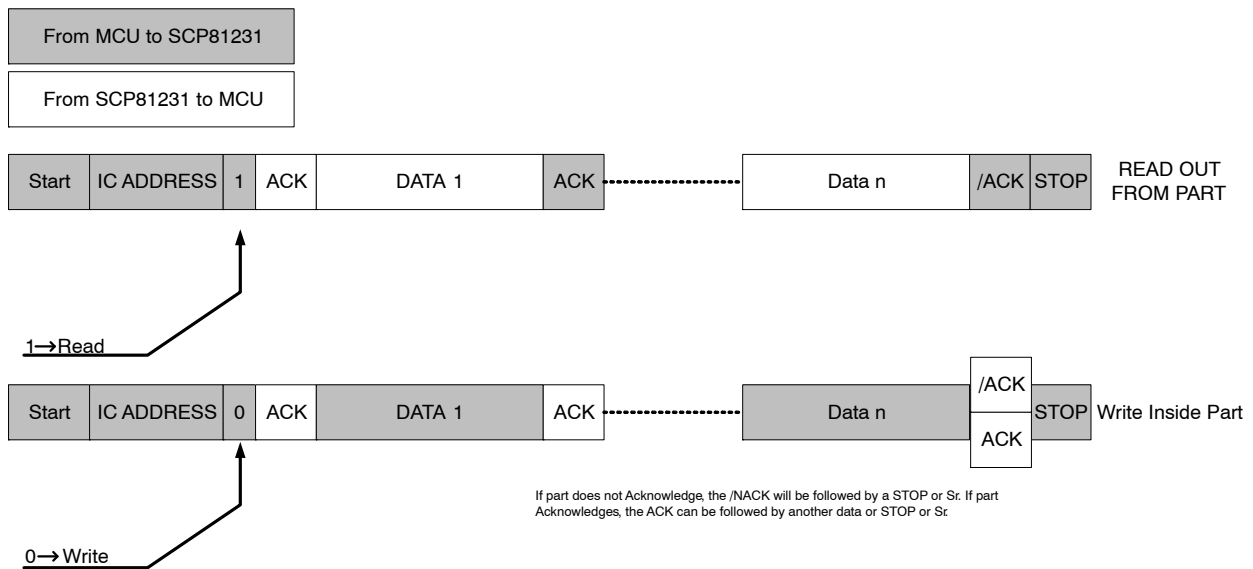

Figure 24. General Protocol Description

SCP81231

Read out from part

The master will first make a "Pseudo Write" transaction with no data to set the internal address register. Then, a stop

then start or a repeated start will initiate the Read transaction from the register address the initial Write transaction was pointed to:

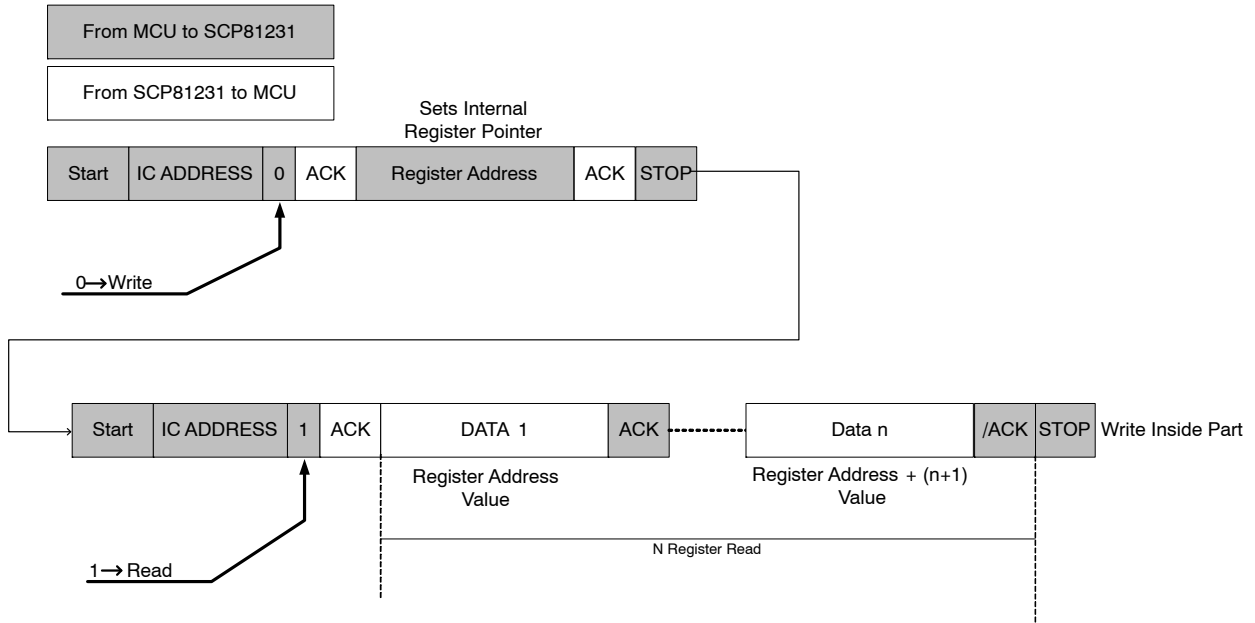

Figure 25. Read Out From Part

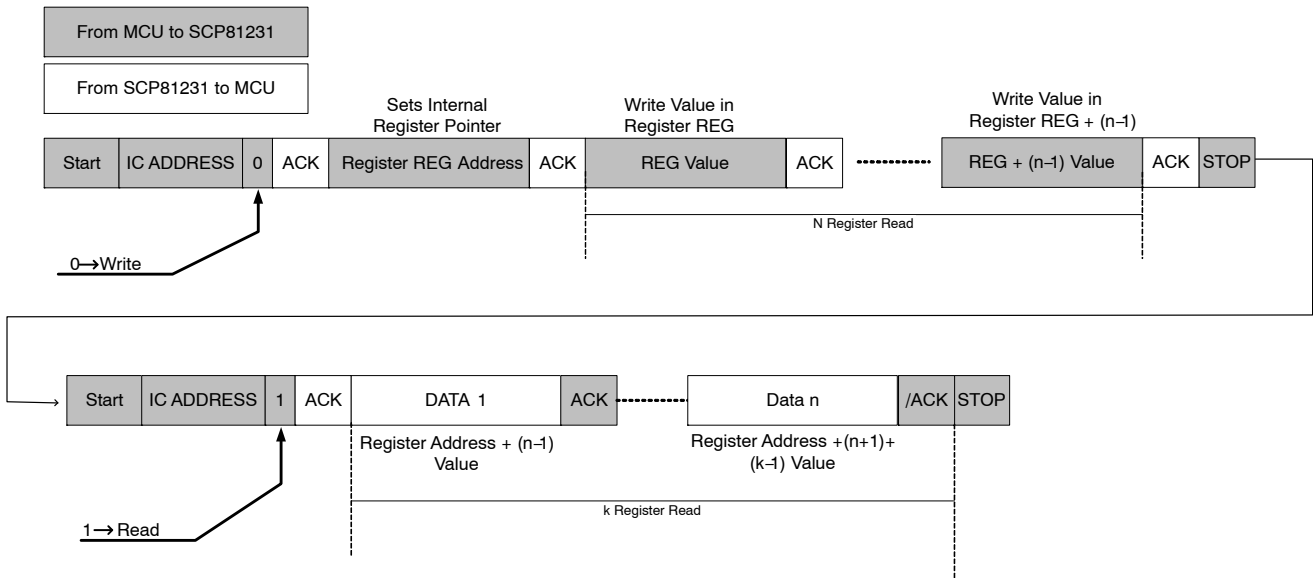

Figure 26. Write Followed by Read Transaction

SCP81231

Write In Part

Write operation will be achieved by only one transaction. After the chip address, the MCU first data will be the internal

register desired to access, the following data will be the data written in REG, REG + 1, REG + 2, ..., REG + (n-1).

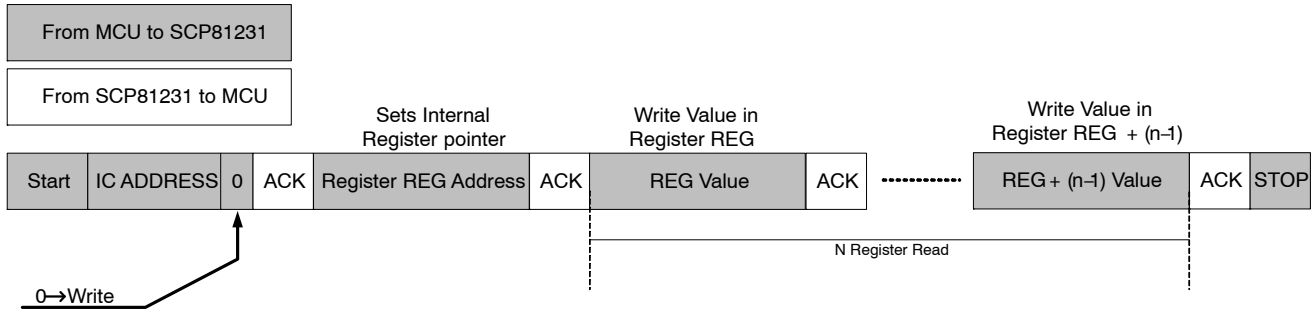

Figure 27. Write in n Registers

Dead Battery Control

The SCP81231 has a built-in dead battery control circuit. The dead battery circuit input voltage is connected to DBIN pin and the output is delivered to DBOUT. The dead battery circuit does not regulate the voltage from DBIN, but rather passes it to DBOUT with a minimum of voltage drop. Ideally 5 V should be applied to DBIN to comply with the old USB Specification. The circuit performs two functions: to regulate the output current and to cutoff the output voltage until commanded to generate the required output. The

circuit is normally connected to the output of the converter and remains off blocking 5 V, 12 V, or 20 V from DBIN until a port is connected to another port that has a dead battery. Upon detection of the dead battery port, the circuit is activated to supply enough energy for the system to communicate and ask for more power. Alternatively, the dead battery circuit can be used as a current limited supply for I2C. The circuit is capable of a typical output power of 350 mW.

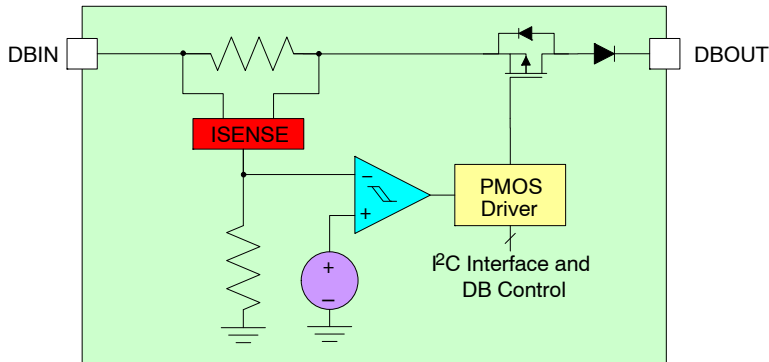

Figure 28. Dead Battery Control Circuitry

Table 18 is described in details in the register map spreadsheet on the website. It will be also presented in an application note.

Table 18. I2C Register Map Bit Detail

	ADDR (Hex)	Bit 7	Bit 6	Bit 5	Bit 4	Bit 3	Bit 2	Bit 1	Bit 0
User-programmable Registers	00h	-	-	-	-	en_int	en_mask	en_pup	en_pol
	01h	dac_target							
	02h	-	-	-	-	-	-	slew_rate	
	03h	-	-	-	dac_target_lsb	-	pwm_frequency		
	04h	-	-	cs2_dchrg	cs1_dchrg	-	dead_battery_en	cfet	pfet
	05h	-	-	-	-	-	-	ocp_clim_pos	
	06h	-	-	-	-	-	cs1_clim_pos		
	07h	gm_amp_config	hi_gm_amp_setting			gm_manual	lo_gm_amp_setting		
	08h	-	-	dis_adc	-	amux_sel	amux_trigger		
	09h	int_mask_i2c_ack	int_mask_vchn	-	int_mask_tsd	int_mask_pg_int	int_mask_ocp_p	int_mask_ovp	int_mask_cs_clind
0Ah	-	-	-	-	-	-	-	int_shut_down	
-	0B .. 0Fh								
User read-only registers	10h	vout							
	11h	vin							
	12h	cs2							
	13h								
	14h	i2c_ack	vchn	-	tsd	pg_int	ocp_p	ovp	cs_clind
	15h	-	-	-	-	-	-	-	shut_down

DESIGN CONSIDERATIONS

dv/dt Induced False Turn On

In synchronous buck converters, there is a well-known phenomenon called “low side false turn-on,” or “dv/dt induced turn on”, which can be potentially dangerous for the switch itself and the reliability of the entire converter.

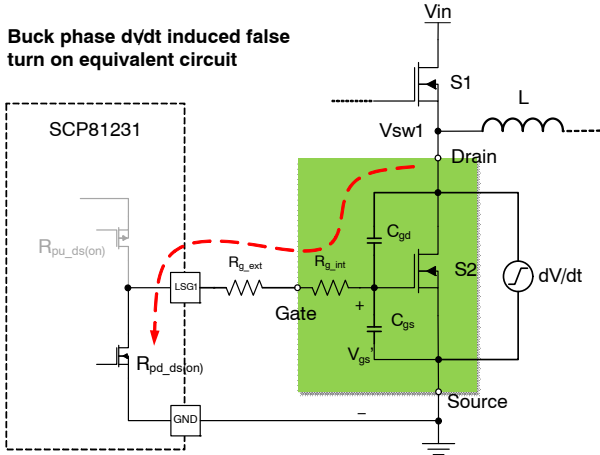

Figure 29. dv/dt Induced False Turn-on Equivalent Circuit of a Buck Converter

Figure 29 shows false turn on equivalent circuit of the buck converter at the moment a positive dv/dt transition appears across the drain-to-source junction. The detailed analysis of this phenomenon can be found in [Gate Driver Design Considerations for 4-Switch Buck-Boost Converters](#).

Select the Switching Power MOSFET

The MOSFETs used in the power stage of the converter should have a maximum drain-to-source voltage rating that exceeds the sum of steady state maximum drain-to-source voltage and the turn-off voltage spike with a considerable margin (20%~50%).

When selecting the switching power MOSFET, the MOSFET gate capacitance should be considered carefully to avoid overloading the 5 V LDO. For one MOSFET, the allowed maximum total gate charge Q_g can be estimated by Equation 2:

$$Q_g = \frac{I_{driver}}{f_{sw}} \tag{eq. 2}$$

where I_{driver} is the gate drive current and f_{sw} is the switching frequency.

It is recommended to select the MOSFETs with smaller than 3 nF input capacitance (C_{iss}). The gate threshold voltage should be higher than 1.0 V due to the internal adaptive non-overlap gate driver circuit.

In order to prevent dv/dt induced turn-on, the criteria for selecting a low side switch is based on the turn-on threshold voltage $V_{GS(th)}$ and the $Q_{gd}/Q_{gs(th)}$ ratio. It is recommended to use MOSFETs whose turn-on threshold voltage $V_{gs(th)} > 1$ V, because SCP81231 senses the gate-source voltage as an indicator of the state of the high side MOSFET. If the sensed voltage is lower than 1 V, it is considered that the high side MOSFET is off. After that, the low side MOSFET can be turned on after a constant 15 ns deadtime. $Q_{gs(th)}$ is the gate-to-source charge before the gate voltage reaches the threshold voltage. Lowering C_{gd} will reduce dv/dt induced voltage magnitude. Moreover, it also depends on dt/C_{gs} , V_{ds} and threshold voltage V_{th} . One way of interpreting the dv/dt induced turn-on problem is when V_{ds} reaches the input voltage, the Miller charge should be smaller than the total charge on C_{gs} at the V_{th} level, so that the low side switch will not be turned on. Then we will have the following relation:

$$V_{gs} = \frac{C_{gd}}{C_{gd} + C_{gs}} \times V_{ds} < V_{gs(th)} \tag{eq. 3}$$

$$Q_{gd} < Q_{GS(th)} \tag{eq. 4}$$

We can simply use Equation 4 to evaluate the low side switch device’s immunity to dv/dt induced turn on. Ideally, the charge Q_{gd} should not be greater than $2 \cdot Q_{gs(th)}$ in order to leave enough margin.

Selecting Gate Drive Resistors

To increase the converter’s dv/dt immunity, the dv/dt control is one approach which is usually related to the gate driver circuit. A first intuitive method is to use higher pull up resistance and gate resistance for the high side switch. This would slow down the turn on of the high side switch, effectively decreasing the dv/dt. Table 19 shows the recommended value for MOSFETs’ external gate drive resistors.

Table 19. RECOMMENDED VALUE FOR EXTERNAL GATE DRIVE RESISTORS

HSG1	0Ω
LSG1	0Ω

Since 0 ohm gate resistors are recommended, an alternative resistor can be placed in series with the bootstrap capacitor if the turn-on speed of the high side MOSFET needs to be slowed down. The circuit is shown in Figure 30. An alternative approach is to add an RC snubber circuit to the switching nodes VSW1. This is the most direct way to reduce the dv/dt. The side effect of the above two methods are that losses would be increased because of slow switching speed.

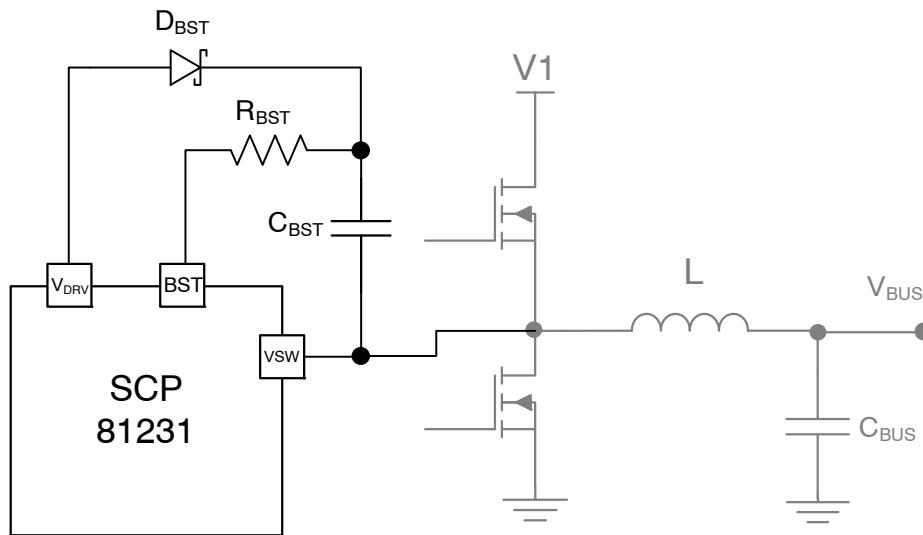

Figure 30. Bootstrap Circuit with Recommended Resistor R_{BST}

LAYOUT GUIDELINES

Electrical Layout Considerations

Good electrical layout is a key to make sure proper operation, high efficiency, and noise reduction.

- **Current Sensing:** Run two dedicated trace with decent width in parallel (close to each other to minimize the loop area) from the two terminals of the input side or output side current sensing resistor to the IC. Place the common-mode RC filter components in general proximity of the controller.

Route the traces into the pads from the inside of the current sensing resistor. The drawing below shows how to rout the traces.

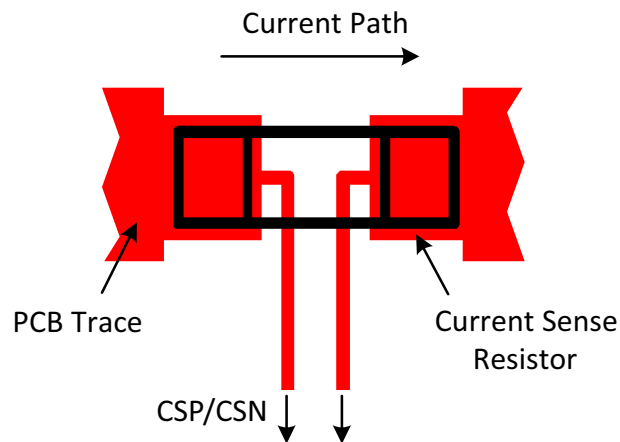

- **Gate Driver:** Run the high side gate, low side gate and switching node traces in a parallel fashion with decent width. Avoid any sensitive analog signal trace from crossing over or getting close. Recommend routing VSW1 trace to high-side MOSFET source pin instead of copper pour area. The controller should be placed close to the switching MOSFETs gate terminals and

keep the gate drive signal traces short for a clean MOSFET drive. It's OK to place the controller on the opposite side of the MOSFETs.

- **I2C Communication:** SDA and SCL pins are digital pins. Run SDA and SCL traces in parallel and reduce the loop area. Avoid any sensitive analog signal trace or noise source from crossing over or getting close.
- **V1 Pin:** Input for the internal LDO. Place a decoupling capacitor in general proximity of the controller. Run a dedicated trace from system input bus to the pin and do not route near the switching traces.
- **VCC Decoupling:** Place decoupling caps as close as possible to the controller VCC pin. Place the RC filter connecting with VDRV pin in general proximity of the controller. The filter resistor should be not higher than $10\ \Omega$ to prevent large voltage drop.
- **VDRV Decoupling:** Place decoupling caps as close as possible to the controller VDRV pin.
- **Input Decoupling:** The device should be well decoupled by input capacitors and input loop area should be as small as possible to reduce parasitic inductance, input voltage spike, and noise emission. Usually, a small low-ESL MLCC is placed very close to the input port. Place these capacitors on the same PCB layer with the MOSFETs instead of on different layers and using vias to make the connection.
- **Output Decoupling:** The output capacitors should be as close as possible to the load.
- **Switching Node:** The converter's switching node should be a copper pour to carry the current, but compact because it is also a noise source of electrical and magnetic field radiation. Place the inductor and the switching MOSFETs on the same layer of the PCB.
- **Bootstrap:** The bootstrap cap and an option resistor need to be in general close to the controller and directly

SCP81231

connected between pin BST1 and pin VSW1 respectively.

- **Ground:** It would be good to have separated ground planes for PGND and AGND and connect the AGND planes to PGND through a dedicated net tie or 0 Ω resistor.
- **Voltage Sense:** Route a “quiet” path for the input and output voltage sense. AGND could be used as a remote ground sense when differential sense is preferred.
- **Compensation Network:** The compensation network should be close to the controller. Keep FB trace short to minimize its capacitance to ground.

Thermal Layout Considerations

Good thermal layout helps power dissipation and junction temperature reduction.

- The exposed pads must be well soldered on the board.
- A four or more layers PCB board with solid ground planes is preferred for better heat dissipation.
- More free vias are welcome to be around IC and underneath the exposed pads to connect the inner ground layers to reduce thermal impedance.
- Use large area copper pour to help thermal conduction and radiation.
- Do not put the inductor too close to the IC, thus the heat sources are distributed.

SCP81231

PACKAGE DIMENSIONS

QFN32 5x5, 0.5P
CASE 485CE
ISSUE O

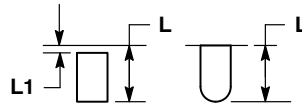
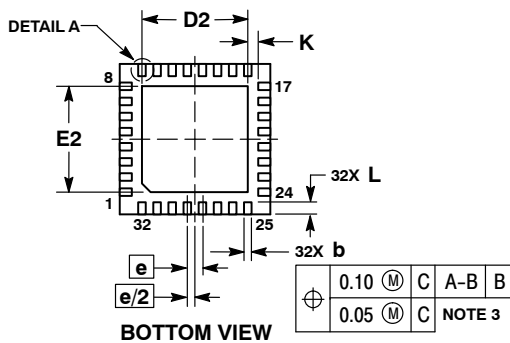
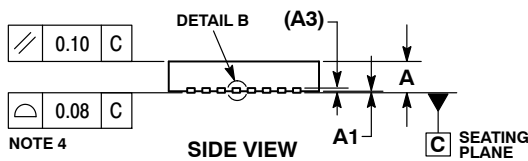
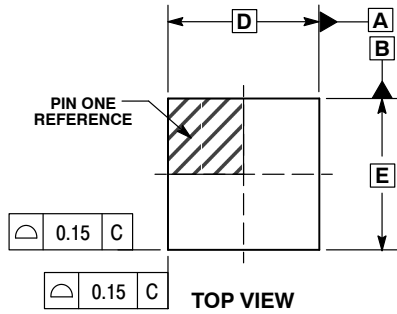

DETAIL A
ALTERNATE
CONSTRUCTIONS

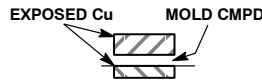

DETAIL B
ALTERNATE
CONSTRUCTION

NOTES:

1. DIMENSIONING AND TOLERANCING PER ASME Y14.5M, 1994.
2. CONTROLLING DIMENSION: MILLIMETERS.
3. DIMENSION b APPLIES TO PLATED TERMINAL AND IS MEASURED BETWEEN 0.15 AND 0.30 MM FROM THE TERMINAL TIP.
4. COPLANARITY APPLIES TO THE EXPOSED PAD AS WELL AS THE TERMINALS.

MILLIMETERS		
DIM	MIN	MAX
A	0.80	1.00
A1	---	0.05
A3	0.20	REF
b	0.20	0.30
D	5.00	BSC
D2	3.40	3.60
E	5.00	BSC
E2	3.40	3.60
e	0.50	BSC
K	0.20	---
L	0.30	0.50
L1	---	0.15

RECOMMENDED SOLDERING FOOTPRINT*

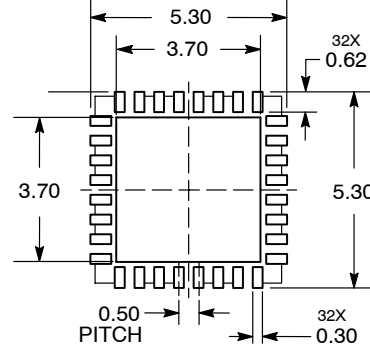

DIMENSIONS: MILLIMETERS

*For additional information on our Pb-Free strategy and soldering details, please download the ON Semiconductor Soldering and Mounting Techniques Reference Manual, SOLDERRM/D.

ON Semiconductor and are trademarks of Semiconductor Components Industries, LLC dba ON Semiconductor or its subsidiaries in the United States and/or other countries. ON Semiconductor owns the rights to a number of patents, trademarks, copyrights, trade secrets, and other intellectual property. A listing of ON Semiconductor's product/patent coverage may be accessed at www.onsemi.com/site/pdf/Patent-Marking.pdf. ON Semiconductor reserves the right to make changes without further notice to any products herein. ON Semiconductor makes no warranty, representation or guarantee regarding the suitability of its products for any particular purpose, nor does ON Semiconductor assume any liability arising out of the application or use of any product or circuit, and specifically disclaims any and all liability, including without limitation special, consequential or incidental damages. Buyer is responsible for its products and applications using ON Semiconductor products, including compliance with all laws, regulations and safety requirements or standards, regardless of any support or applications information provided by ON Semiconductor. "Typical" parameters which may be provided in ON Semiconductor data sheets and/or specifications can and do vary in different applications and actual performance may vary over time. All operating parameters, including "Typicals" must be validated for each customer application by customer's technical experts. ON Semiconductor does not convey any license under its patent rights nor the rights of others. ON Semiconductor products are not designed, intended, or authorized for use as a critical component in life support systems or any FDA Class 3 medical devices or medical devices with a same or similar classification in a foreign jurisdiction or any devices intended for implantation in the human body. Should Buyer purchase or use ON Semiconductor products for any such unintended or unauthorized application, Buyer shall indemnify and hold ON Semiconductor and its officers, employees, subsidiaries, affiliates, and distributors harmless against all claims, costs, damages, and expenses, and reasonable attorney fees arising out of, directly or indirectly, any claim of personal injury or death associated with such unintended or unauthorized use, even if such claim alleges that ON Semiconductor was negligent regarding the design or manufacture of the part. ON Semiconductor is an Equal Opportunity/Affirmative Action Employer. This literature is subject to all applicable copyright laws and is not for resale in any manner.

PUBLICATION ORDERING INFORMATION

LITERATURE FULFILLMENT:
Literature Distribution Center for ON Semiconductor
19521 E. 32nd Pkwy, Aurora, Colorado 80011 USA
Phone: 303-675-2175 or 800-344-3860 Toll Free USA/Canada
Fax: 303-675-2176 or 800-344-3867 Toll Free USA/Canada
Email: orderlit@onsemi.com

N. American Technical Support: 800-282-9855 Toll Free
USA/Canada
Europe, Middle East and Africa Technical Support:
Phone: 421 33 790 2910

ON Semiconductor Website: www.onsemi.com
Order Literature: <http://www.onsemi.com/orderlit>

For additional information, please contact your local Sales Representative