



## 6 Channel Capacitive Touch Sensor with 6 LED Drivers

### PRODUCT FEATURES

Data Brief

#### General Description

The CAP1066 is a multiple channel Capacitive Touch sensor with multiple power LED drivers. It contains six (6) individual Capacitive Touch sensor inputs with programmable sensitivity for use in touch sensor applications. Each sensor automatically recalibrates to compensate for gradual environmental changes.

The CAP1066 also contains six (6) LED drivers that offer full-on / off, variable rate blinking, dimness controls, and breathing. Each of the LED drivers may be linked to one of the sensors to be actuated when a touch is detected. As well, each LED driver may be individually controlled via a host controller.

The CAP1066 offers multiple power states operating at low quiescent currents.

During the Standby mode of operation, one or more Capacitive Touch Sensors are active and all LEDs may be used. If a touch is detected, it will wake the system using the WAKE/SPI\_MOSI pin.

The Deep Sleep mode of operation is the lowest power state available, drawing 3uA of current. During this mode, no sensors are active although all LEDs may be used. Driving the WAKE/SPI\_MOSI pin or communications will wake the device.

#### Applications

- Desktop and Notebook PCs
- LCD Monitors
- Printers
- Appliances

#### Features

- Six (6) Capacitive Touch Sensor Inputs
  - Programmable sensitivity
  - Automatic recalibration
  - Individual thresholds for each button
- Flexible Capacitive Touch Sense algorithm
- Multiple Communication interfaces
  - SMBus / I<sup>2</sup>C compliant interface
  - SMSC BC-Link interface
  - SPI communications
  - Pin selectable communications protocol and multiple slave addresses (SMBus / I<sup>2</sup>C only)
- Low Power operation
  - 3uA quiescent current in Deep Sleep
  - Samples one or more channels in Standby
- Six (6) LED Driver Outputs
  - Open Drain or Push-Pull
  - Programmable blink, breathe, and dimness controls
  - Can be linked to Capacitive Touch Sensors
- Dedicated Wake output flags touches in low power mode
- System RESET pin
- Available in 20-pin 4mm x 4mm RoHS compliant QFN package

#### Block Diagram

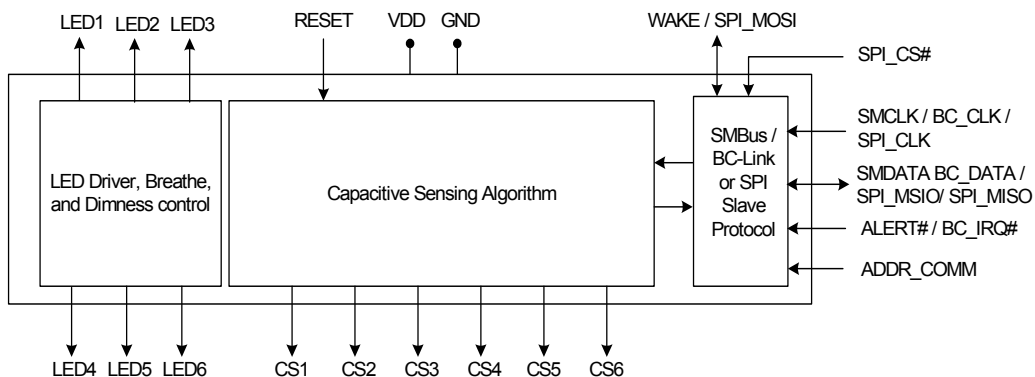

**Note:** I<sup>2</sup>C is a trademark of NXP Semiconductors. SMSC BC-Link is a trademark of SMSC.

**ORDER NUMBER(S):**

<b>ORDERING NUMBER</b>	<b>PACKAGE</b>	<b>FEATURES</b>
CAP1066-1-BP-TR	20-pin QFN 4mm x 4mm (Lead Free RoHS compliant)	Six Capacitive Touch Sensors, Six LED drivers, Dedicated Wake, Reset, SMBus / BC-Link / SPI interfaces

**REEL SIZE IS 4,000 PIECES****This product meets the halogen maximum concentration values per IEC61249-2-21****For RoHS compliance and environmental information, please visit [www.smSC.com/rohs](http://www.smSC.com/rohs)**

80 ARKAY DRIVE, HAUPPAUGE, NY 11788 (631) 435-6000, FAX (631) 273-3123

Copyright © 2009 SMSC or its subsidiaries. All rights reserved.

Circuit diagrams and other information relating to SMSC products are included as a means of illustrating typical applications. Consequently, complete information sufficient for construction purposes is not necessarily given. Although the information has been checked and is believed to be accurate, no responsibility is assumed for inaccuracies. SMSC reserves the right to make changes to specifications and product descriptions at any time without notice. Contact your local SMSC sales office to obtain the latest specifications before placing your product order. The provision of this information does not convey to the purchaser of the described semiconductor devices any licenses under any patent rights or other intellectual property rights of SMSC or others. All sales are expressly conditional on your agreement to the terms and conditions of the most recently dated version of SMSC's standard Terms of Sale Agreement dated before the date of your order (the "Terms of Sale Agreement"). The product may contain design defects or errors known as anomalies which may cause the product's functions to deviate from published specifications. Anomaly sheets are available upon request. SMSC products are not designed, intended, authorized or warranted for use in any life support or other application where product failure could cause or contribute to personal injury or severe property damage. Any and all such uses without prior written approval of an Officer of SMSC and further testing and/or modification will be fully at the risk of the customer. Copies of this document or other SMSC literature, as well as the Terms of Sale Agreement, may be obtained by visiting SMSC's website at <http://www.smSC.com>. SMSC is a registered trademark of Standard Microsystems Corporation ("SMSC"). Product names and company names are the trademarks of their respective holders.

**SMSC DISCLAIMS AND EXCLUDES ANY AND ALL WARRANTIES, INCLUDING WITHOUT LIMITATION ANY AND ALL IMPLIED WARRANTIES OF MERCHANTABILITY, FITNESS FOR A PARTICULAR PURPOSE, TITLE, AND AGAINST INFRINGEMENT AND THE LIKE, AND ANY AND ALL WARRANTIES ARISING FROM ANY COURSE OF DEALING OR USAGE OF TRADE. IN NO EVENT SHALL SMSC BE LIABLE FOR ANY DIRECT, INCIDENTAL, INDIRECT, SPECIAL, PUNITIVE, OR CONSEQUENTIAL DAMAGES; OR FOR LOST DATA, PROFITS, SAVINGS OR REVENUES OF ANY KIND; REGARDLESS OF THE FORM OF ACTION, WHETHER BASED ON CONTRACT; TORT; NEGLIGENCE OF SMSC OR OTHERS; STRICT LIABILITY; BREACH OF WARRANTY; OR OTHERWISE; WHETHER OR NOT ANY REMEDY OF BUYER IS HELD TO HAVE FAILED OF ITS ESSENTIAL PURPOSE, AND WHETHER OR NOT SMSC HAS BEEN ADVISED OF THE POSSIBILITY OF SUCH DAMAGES.**

# Package Outline

## CAP1066 Package Drawings

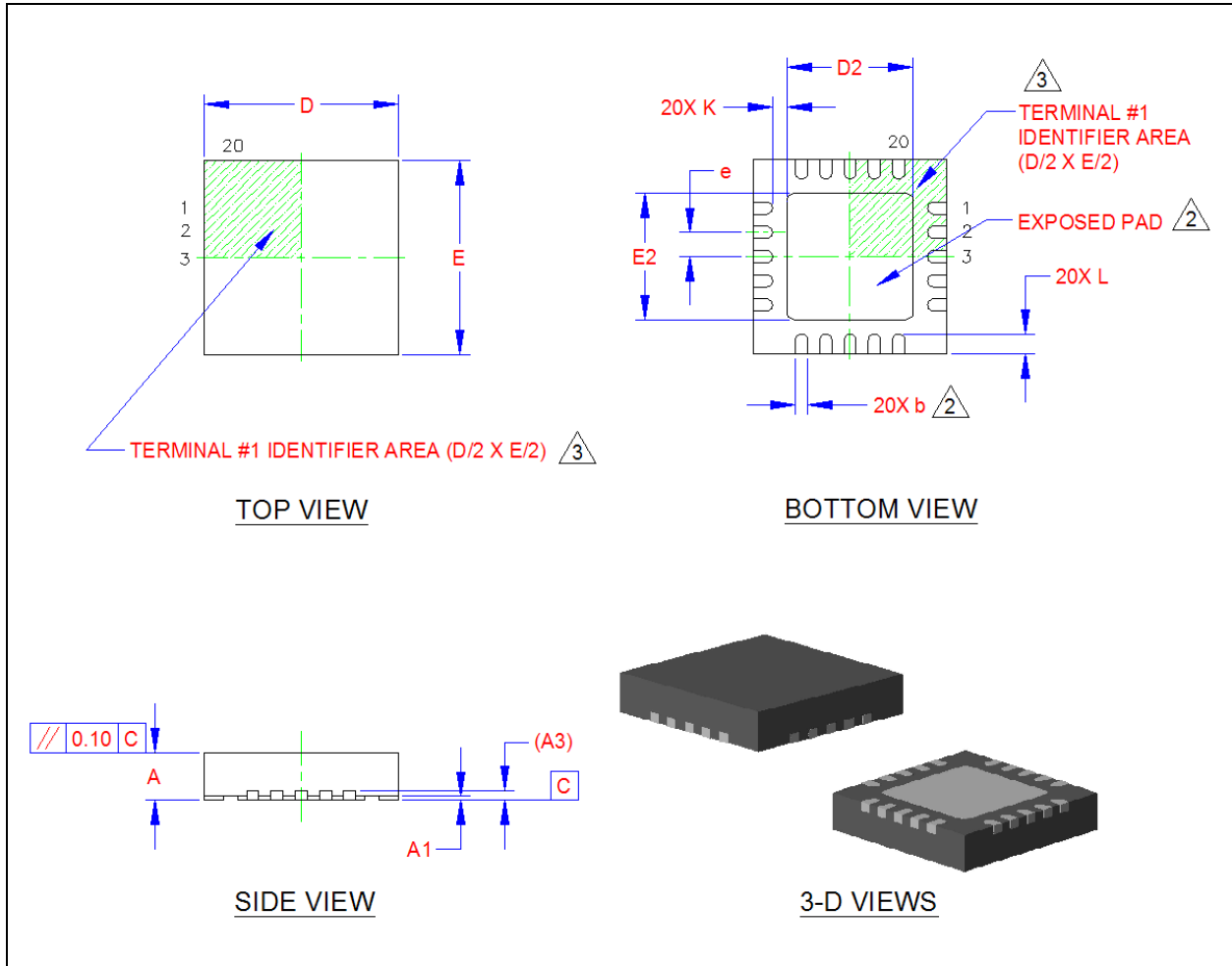
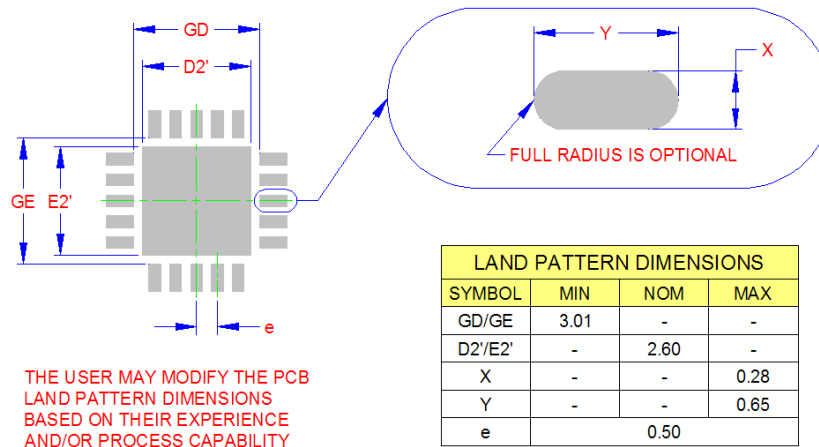

Figure 1 20-Pin QFN 4mm x 4mm Package Drawing

COMMON DIMENSIONS					
SYMBOL	MIN	NOM	MAX	NOTE	REMARK
A	0.80	0.85	0.90	-	OVERALL PACKAGE HEIGHT
A1	0	0.02	0.05	-	STANDOFF
A3	0.20 REF			-	LEAD-FRAME THICKNESS
D/E	3.90	4.00	4.10	-	X/Y BODY SIZE
D2/E2	2.50	2.60	2.70	2	X/Y EXPOSED PAD SIZE
L	0.35	0.40	0.45	-	TERMINAL LENGTH
b	0.18	0.25	0.30	2	TERMINAL WIDTH
K	0.20	-	-	-	TERMINAL TO PAD DISTANCE
e	0.50 BSC			-	TERMINAL PITCH

**NOTES:**

1. ALL DIMENSIONS ARE IN MILLIMETERS.
2. POSITION TOLERANCE OF EACH TERMINAL AND EXPOSED PAD IS  $\pm 0.05\text{mm}$  AT MAXIMUM MATERIAL CONDITION. DIMENSIONS "b" APPLIES TO PLATED TERMINALS AND IT IS MEASURED BETWEEN 0.15 AND 0.30 mm FROM THE TERMINAL TIP.
3. DETAILS OF TERMINAL #1 IDENTIFIER ARE OPTIONAL BUT MUST BE LOCATED WITHIN THE AREA INDICATED.

**Figure 2 20-Pin QFN 4mm x 4mm Package Dimensions**

**RECOMMENDED PCB LAND PATTERN**
**Figure 3 20-Pin QFN 4mm x 4mm PCB Drawing**