



# Single/Dual Single-Wire Temp Sensor in SOT23-5 Using SMSC BudgetBus™ Sensor Interface

## PRODUCT FEATURES

Data Brief

### General Description

The EMC1201 and EMC1202 are temperature sensors that communicate with a host over a single-wire SMSC BudgetBus™ Sensor Interface. The EMC1201 has an internal temperature sensor and the EMC1202 adds one remote diode. Packaged in a SOT23-5, the EMC1201 provides an accurate, low-cost, low-current, solution for critical temperature monitoring in applications such as embedded systems or computers. When used in combination with an SMSC Super I/O host, such as a keyboard controller, a complete thermal management system is created. A power down mode extends battery life in portable applications. The internal 11-bit sigma delta temperature-to-digital converter provides superb linearity, high accuracy and excellent noise immunity.

PART NUMBER	INTERNAL TEMPERATURE MONITOR	EXTERNAL TEMPERATURE MONITOR
EMC1201	1	0
EMC1202	1	1

### Features

- Single-wire SMSC BudgetBus™ Sensor Interface
- Low Power, 3.0V to 3.6V Supply
  - < 50uA at 1 conversion per second
  - < 3uA in Standby
- External Temperature Sensor
  - Range -63.875° C to +191.875° C
  - 0.125° C resolution
  - ±1° C Accuracy 60° C to 100° C
  - Diode Fault Reporting
- Self Contained Internal Temperature Sensor
  - Range 0° C to +85° C
  - 0.125° C resolution
  - ±3° C Accuracy 0° C to 85° C
- SOT23-5 Lead-free RoHS Compliant Packages

### Applications

- Desktop and Notebook Computers
- Thermostats
- Smart batteries
- Industrial/Automotive
- Other Electronic Systems

### Simplified Block Diagram

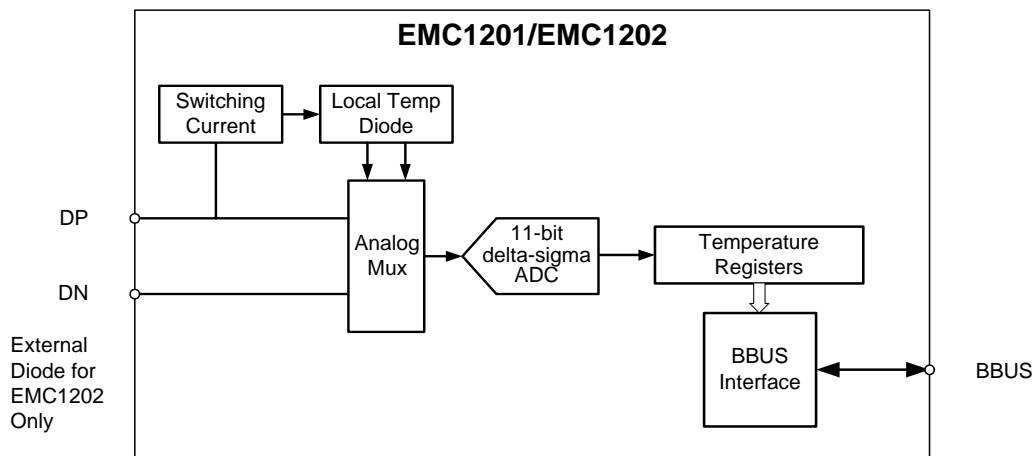



**ORDER NUMBERS:**

**EMC1201-AGZQ-TR IN 5 PIN, SOT23-5 LEAD-FREE ROHS COMPLIANT PACKAGE**

**EMC1202-AGZQ-TR IN 5 PIN, SOT23-5 LEAD-FREE ROHS COMPLIANT PACKAGE**



80 ARKAY DRIVE, HAUPPAUGE, NY 11788 (631) 435-6000, FAX (631) 273-3123

Copyright © 2008 SMSC or its subsidiaries. All rights reserved.

Circuit diagrams and other information relating to SMSC products are included as a means of illustrating typical applications. Consequently, complete information sufficient for construction purposes is not necessarily given. Although the information has been checked and is believed to be accurate, no responsibility is assumed for inaccuracies. SMSC reserves the right to make changes to specifications and product descriptions at any time without notice. Contact your local SMSC sales office to obtain the latest specifications before placing your product order. The provision of this information does not convey to the purchaser of the described semiconductor devices any licenses under any patent rights or other intellectual property rights of SMSC or others. All sales are expressly conditional on your agreement to the terms and conditions of the most recently dated version of SMSC's standard Terms of Sale Agreement dated before the date of your order (the "Terms of Sale Agreement"). The product may contain design defects or errors known as anomalies which may cause the product's functions to deviate from published specifications. Anomaly sheets are available upon request. SMSC products are not designed, intended, authorized or warranted for use in any life support or other application where product failure could cause or contribute to personal injury or severe property damage. Any and all such uses without prior written approval of an Officer of SMSC and further testing and/or modification will be fully at the risk of the customer. Copies of this document or other SMSC literature, as well as the Terms of Sale Agreement, may be obtained by visiting SMSC's website at <http://www.smisc.com>. SMSC is a registered trademark of Standard Microsystems Corporation ("SMSC"). Product names and company names are the trademarks of their respective holders.

**SMSC DISCLAIMS AND EXCLUDES ANY AND ALL WARRANTIES, INCLUDING WITHOUT LIMITATION ANY AND ALL IMPLIED WARRANTIES OF MERCHANTABILITY, FITNESS FOR A PARTICULAR PURPOSE, TITLE, AND AGAINST INFRINGEMENT AND THE LIKE, AND ANY AND ALL WARRANTIES ARISING FROM ANY COURSE OF DEALING OR USAGE OF TRADE. IN NO EVENT SHALL SMSC BE LIABLE FOR ANY DIRECT, INCIDENTAL, INDIRECT, SPECIAL, PUNITIVE, OR CONSEQUENTIAL DAMAGES; OR FOR LOST DATA, PROFITS, SAVINGS OR REVENUES OF ANY KIND; REGARDLESS OF THE FORM OF ACTION, WHETHER BASED ON CONTRACT; TORT; NEGLIGENCE OF SMSC OR OTHERS; STRICT LIABILITY; BREACH OF WARRANTY; OR OTHERWISE; WHETHER OR NOT ANY REMEDY OF BUYER IS HELD TO HAVE FAILED OF ITS ESSENTIAL PURPOSE, AND WHETHER OR NOT SMSC HAS BEEN ADVISED OF THE POSSIBILITY OF SUCH DAMAGES.**

# Package Outline

Revision 1.0 (06-10-08)

PRODUCT PREVIEW 3

SMSC PartNumber

Single/Dual Single-Wire Temp Sensor in SOT23-5 Using SMSC BudgetBus™ Sensor Interface

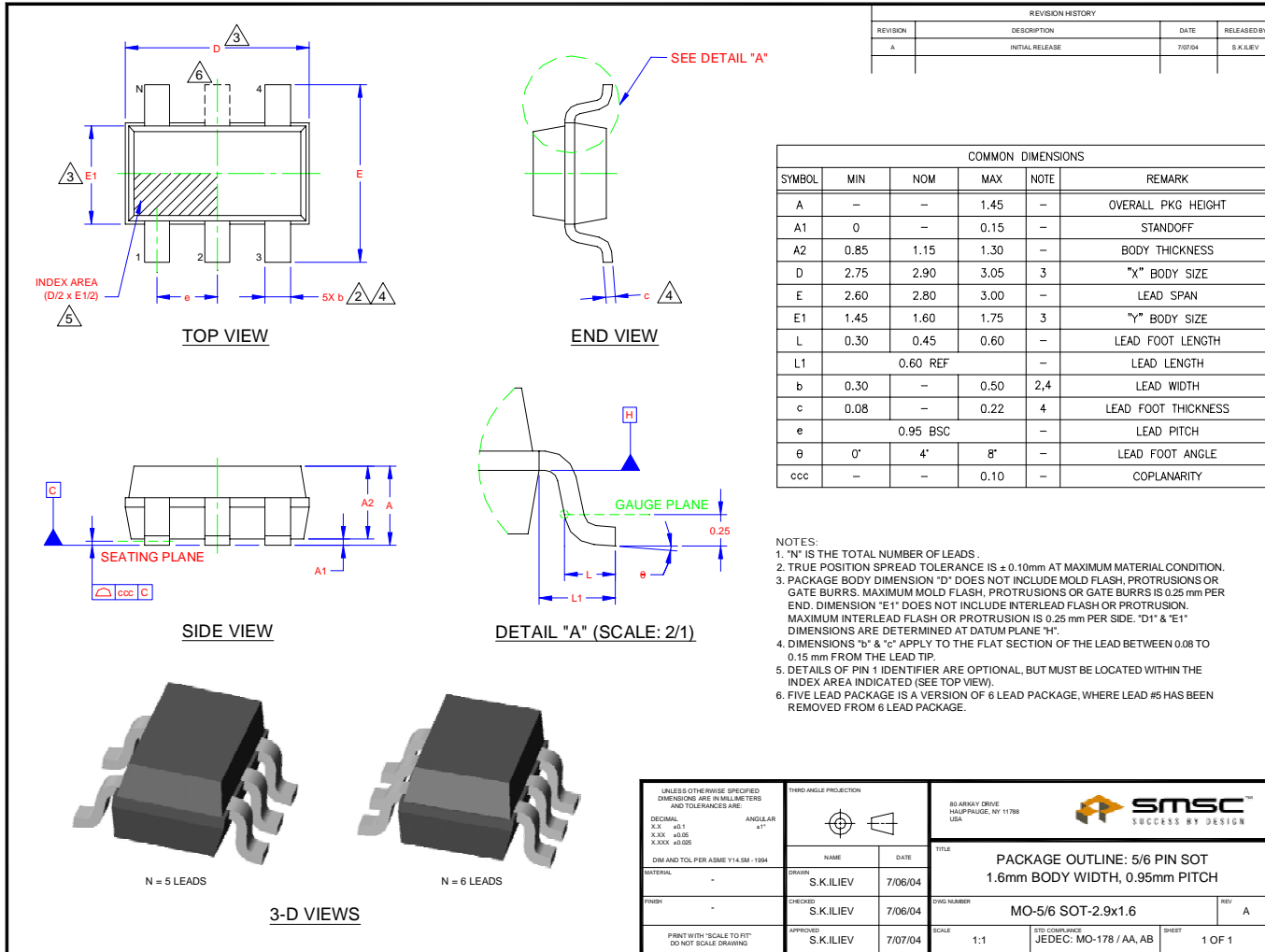

Figure 1 EMC1201/EMC1202 5 Pin SOT Package Outline; 1.6mm Body Width, 0.95mm Pitch