



USB2503/USB2503A



## Integrated USB 2.0 Compatible 3-Port Hub

### PRODUCT FEATURES

Data Brief

- Integrated USB 2.0 Compatible 3-Port Hub
  - 3 Transaction Translators for highest performance
  - High-Speed (480Mbps/s), Full-Speed (12Mbps/s) and Low-Speed (1.5Mbps/s) compatible
  - Full power management with per port or ganged, selectable power control
  - Detects Bus-Power/Self-Power source and changes mode automatically
- Complete USB Specification 2.0 Compatibility
  - Includes USB 2.0 Transceivers
- VID/PID/DID, and Port Configuration for Hub via:
  - Single Serial I<sup>2</sup>C EEPROM
  - SMBus Slave Port
- Default VID/PID/DID, allows functionality when configuration EEPROM is absent
- Hardware Strapping options allow for configuration without an external EEPROM or SMBus Host
- On-Board 24MHz Crystal Driver Circuit or 24 MHz external clock driver
- Internal PLL for 480MHz USB 2.0 Sampling
- Internal 1.8V Linear Voltage Regulator
- Integrated USB termination and Pull-up/Pull-down resistors
- Internal Short Circuit protection of USB differential signal pins
- 1.8 Volt Low Power Core Operation
- 3.3 Volt I/O with 5V Input Tolerance
- 48 Pin QFN lead-free RoHS compliant package

**ORDER NUMBERS:****USB2503/USB2503A-HZH FOR 48 PIN QFN LEAD-FREE ROHS COMPLIANT PACKAGE**

80 ARKAY DRIVE, HAUPPAUGE, NY 11788 (631) 435-6000, FAX (631) 273-3123

Copyright © 2007 SMSC or its subsidiaries. All rights reserved.

Circuit diagrams and other information relating to SMSC products are included as a means of illustrating typical applications. Consequently, complete information sufficient for construction purposes is not necessarily given. Although the information has been checked and is believed to be accurate, no responsibility is assumed for inaccuracies. SMSC reserves the right to make changes to specifications and product descriptions at any time without notice. Contact your local SMSC sales office to obtain the latest specifications before placing your product order. The provision of this information does not convey to the purchaser of the described semiconductor devices any licenses under any patent rights or other intellectual property rights of SMSC or others. All sales are expressly conditional on your agreement to the terms and conditions of the most recently dated version of SMSC's standard Terms of Sale Agreement dated before the date of your order (the "Terms of Sale Agreement"). The product may contain design defects or errors known as anomalies which may cause the product's functions to deviate from published specifications. Anomaly sheets are available upon request. SMSC products are not designed, intended, authorized or warranted for use in any life support or other application where product failure could cause or contribute to personal injury or severe property damage. Any and all such uses without prior written approval of an Officer of SMSC and further testing and/or modification will be fully at the risk of the customer. Copies of this document or other SMSC literature, as well as the Terms of Sale Agreement, may be obtained by visiting SMSC's website at <http://www.smSC.com>. SMSC is a registered trademark of Standard Microsystems Corporation ("SMSC"). Product names and company names are the trademarks of their respective holders.

**SMSC DISCLAIMS AND EXCLUDES ANY AND ALL WARRANTIES, INCLUDING WITHOUT LIMITATION ANY AND ALL IMPLIED WARRANTIES OF MERCHANTABILITY, FITNESS FOR A PARTICULAR PURPOSE, TITLE, AND AGAINST INFRINGEMENT AND THE LIKE, AND ANY AND ALL WARRANTIES ARISING FROM ANY COURSE OF DEALING OR USAGE OF TRADE. IN NO EVENT SHALL SMSC BE LIABLE FOR ANY DIRECT, INCIDENTAL, INDIRECT, SPECIAL, PUNITIVE, OR CONSEQUENTIAL DAMAGES; OR FOR LOST DATA, PROFITS, SAVINGS OR REVENUES OF ANY KIND; REGARDLESS OF THE FORM OF ACTION, WHETHER BASED ON CONTRACT; TORT; NEGLIGENCE OF SMSC OR OTHERS; STRICT LIABILITY; BREACH OF WARRANTY; OR OTHERWISE; WHETHER OR NOT ANY REMEDY OF BUYER IS HELD TO HAVE FAILED OF ITS ESSENTIAL PURPOSE, AND WHETHER OR NOT SMSC HAS BEEN ADVISED OF THE POSSIBILITY OF SUCH DAMAGES.**

## General Description

---

The SMSC 3-Port Hub is fully compliant with the USB 2.0 Specification and will attach to a USB host as a Full-Speed Hub or as a Full-/High-Speed Hub. The 3-Port Hub supports Low-Speed, Full-Speed, and High-Speed (if operating as a High-Speed Hub) downstream devices on all of the enabled downstream ports.

A dedicated Transaction Translator (TT) is available for each downstream facing port. This architecture ensures maximum USB throughput for each connected device when operating with mixed-speed peripherals.

The Hub works with an external USB power distribution switch device to control  $V_{BUS}$  switching to downstream ports, and to limit current and sense over-current conditions.

All required resistors on the USB ports are integrated into the Hub. This includes all series termination resistors on D+ and D- pins and all required pull-down and pull-up resistors on D+ and D- pins. The over-current sense inputs for the downstream facing ports have internal pull-up resistors.

Throughout this document the upstream facing port of the hub will be referred to as the upstream port, and the downstream facing ports will be called the downstream ports.

## OEM Selectable Features

A default configuration is available in the USB2503/USB2503A following a reset. This configuration may be sufficient for some applications. Strapping option pins make it possible to modify a limited subset of the configuration options.

The USB2503/USB2503A may also be configured by an external EEPROM or a microcontroller. When using the microcontroller interface, the Hub appears as an SMBus slave device. If the Hub is pin-strapped for external EEPROM configuration but no external EEPROM is present, then a value of '0' will be written to all configuration data bit fields (the hub will attach to the host with all '0' values).

The 3-Port Hub supports several OEM selectable features:

- Operation as a Self-Powered USB Hub or as a Bus-Powered USB Hub.
- Operation as a Dynamic-Powered Hub (Hub operates as a Bus-Powered device if a local power source is not available and switches to Self-Powered operation when a local power source is available).
- Multiple Transaction Translator (Multi-TT) or Single-TT support.
- Optional OEM configuration via I2C EEPROM or via the industry standard SMBus interface from an external SMBus Host.
- Port power switching on an individual or ganged basis.
- Port over-current monitoring on an individual or ganged basis.
- Compound device support (port is permanently hardwired to a downstream USB peripheral device).
- Hardware strapping options enable configuration of the following features.
  - Non-Removable Ports
  - Port Power Polarity (active high or active low logic)
  - Port Disable
  - Ganged Vs Port power switching and over-current sensing

# Block Diagram

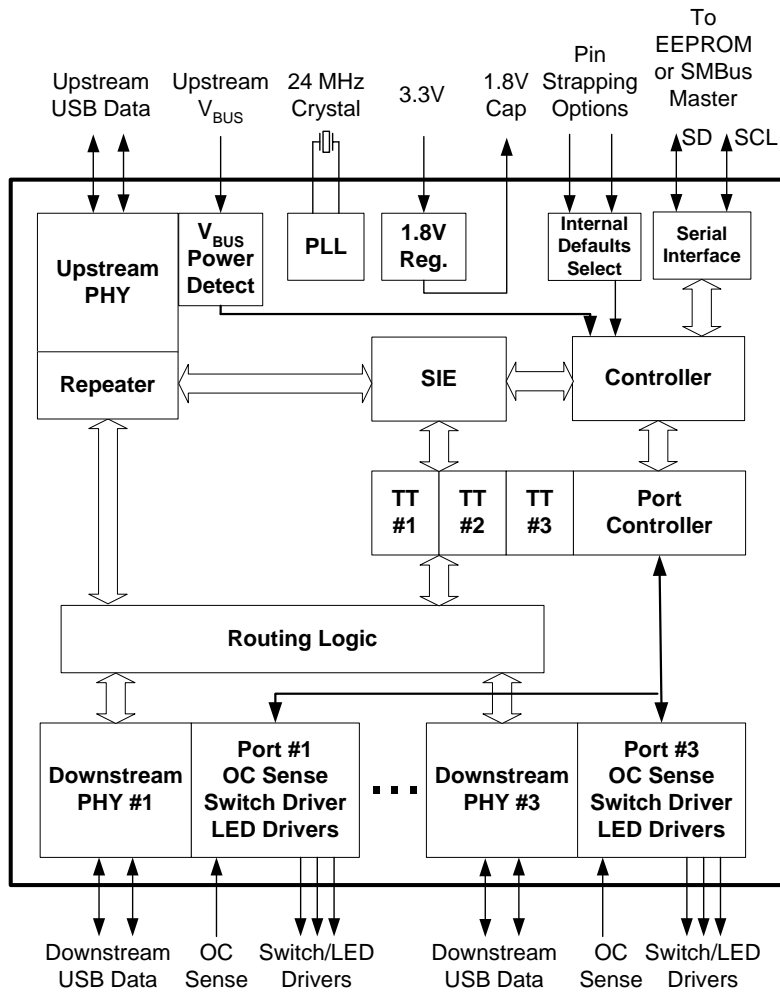

Figure 1 3-Port Block Diagram

# Package Outline

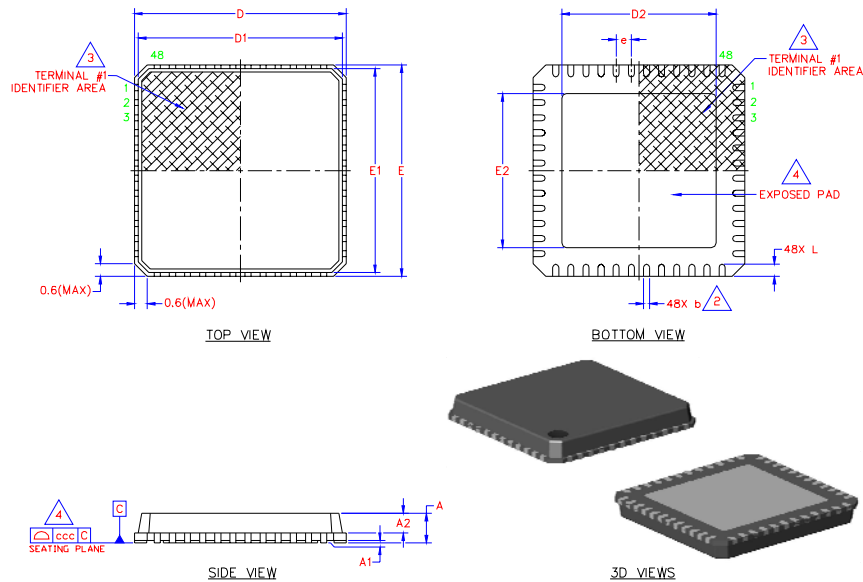

Figure 2 48 Pin QFN Package Outline (7x7 mm body - 0.5 mm pitch)

Table 1 48 Pin QFN Package Parameters

	MIN	NOMINAL	MAX	REMARKS
A	0.70	~	1.00	Overall Package Height
A1	0	0.02	0.05	Standoff
A2	~	~	0.80	Mold Thickness
D	6.85	7.00	7.15	X Overall Size
D1	6.55	~	6.95	X Mold Cap Size
D2	2.25	~	5.60	X exposed Pad Size
E	6.85	7.00	7.15	Y Overall Size
E1	6.55	~	6.95	Y Mold Cap Size
E2	2.25	~	5.60	Y exposed Pad Size
L	0.30	~	0.50	Terminal Length
e	0.50 Basic			Terminal Pitch
b	0.18	~	0.30	Terminal Width
ccc	~	~	0.08	Coplanarity

**Notes:**

1. Controlling Unit: millimeter.
2. Dimension b applies to plated terminals and is measured between 0.15mm and 0.30mm from the terminal tip. Tolerance on the true position of the terminal is  $\pm 0.05$  mm at maximum material conditions (MMC).
3. Details of terminal #1 identifier are optional but must be located within the zone indicated.
4. Coplanarity zone applies to exposed pad and terminals.