



Fan Control Device with High Frequency PWM Support and Hardware Monitoring Features

PRODUCT FEATURES

Data Brief

- 3.3 Volt Operation (5 Volt Tolerant Input Buffers)
- SMBus 2.0 Compliant Interface (Fixed, not Discoverable) with Three Slave Address Options
- Fan Control
 - PWM (Pulse width Modulation) Outputs (3)
 - Fan Tachometer Inputs (4)
 - Programmable automatic fan control based on temperature
 - Backwards compatible with fans requiring lower frequency PWM drive
 - High frequency fan support for 4 wire fans
 - One fan can be controlled from as many as 3 temperature zones
 - Fan ramp rate control for acoustic noise reduction
- Power Savings Modes
 - Two monitoring modes: continuous or cycling (for power savings)
 - Two low power modes when monitoring is off: Sleep and Shutdown
- Temperature Monitor
 - Monitoring of Two Remote Thermal Diodes (+/- 3 deg C accuracy)
 - Internal Ambient Temperature Measurement
 - Limit Comparison of all Monitored Values
 - Interrupt Pin for out-of-limit Temperature Indication
- Voltage Monitor
 - Monitor Power supplies (+2.5V, +5V, +12V, V_{ccp}, and V_{CC})
 - Limit Comparison of all Monitored Values
 - Interrupt Pin for out-of-limit Voltage Indication
- 5 VID (Voltage Identification) Inputs
- XOR Tree Test Mode
- 24-Pin, SSOP Lead-free RoHS Compliant Packages

ORDER NUMBERS:

EMC6D103-CZC FOR 24 PIN, SSOP LEAD-FREE ROHS COMPLIANT PACKAGE

EMC6D103-CZC-TR FOR 24 PIN, SSOP LEAD-FREE ROHS COMPLIANT PACKAGE (TAPE AND REEL)

EVALUATION BOARD IS AVAILABLE



80 ARKAY DRIVE, HAUPPAUGE, NY 11788 (631) 435-6000, FAX (631) 273-3123

Copyright © 2007 SMSC or its subsidiaries. All rights reserved.

Circuit diagrams and other information relating to SMSC products are included as a means of illustrating typical applications. Consequently, complete information sufficient for construction purposes is not necessarily given. Although the information has been checked and is believed to be accurate, no responsibility is assumed for inaccuracies. SMSC reserves the right to make changes to specifications and product descriptions at any time without notice. Contact your local SMSC sales office to obtain the latest specifications before placing your product order. The provision of this information does not convey to the purchaser of the described semiconductor devices any licenses under any patent rights or other intellectual property rights of SMSC or others. All sales are expressly conditional on your agreement to the terms and conditions of the most recently dated version of SMSC's standard Terms of Sale Agreement dated before the date of your order (the "Terms of Sale Agreement"). The product may contain design defects or errors known as anomalies which may cause the product's functions to deviate from published specifications. Anomaly sheets are available upon request. SMSC products are not designed, intended, authorized or warranted for use in any life support or other application where product failure could cause or contribute to personal injury or severe property damage. Any and all such uses without prior written approval of an Officer of SMSC and further testing and/or modification will be fully at the risk of the customer. Copies of this document or other SMSC literature, as well as the Terms of Sale Agreement, may be obtained by visiting SMSC's website at <http://www.smisc.com>. SMSC is a registered trademark of Standard Microsystems Corporation ("SMSC"). Product names and company names are the trademarks of their respective holders.

SMSC DISCLAIMS AND EXCLUDES ANY AND ALL WARRANTIES, INCLUDING WITHOUT LIMITATION ANY AND ALL IMPLIED WARRANTIES OF MERCHANTABILITY, FITNESS FOR A PARTICULAR PURPOSE, TITLE, AND AGAINST INFRINGEMENT AND THE LIKE, AND ANY AND ALL WARRANTIES ARISING FROM ANY COURSE OF DEALING OR USAGE OF TRADE. IN NO EVENT SHALL SMSC BE LIABLE FOR ANY DIRECT, INCIDENTAL, INDIRECT, SPECIAL, PUNITIVE, OR CONSEQUENTIAL DAMAGES; OR FOR LOST DATA, PROFITS, SAVINGS OR REVENUES OF ANY KIND; REGARDLESS OF THE FORM OF ACTION, WHETHER BASED ON CONTRACT; TORT; NEGLIGENCE OF SMSC OR OTHERS; STRICT LIABILITY; BREACH OF WARRANTY; OR OTHERWISE; WHETHER OR NOT ANY REMEDY OF BUYER IS HELD TO HAVE FAILED OF ITS ESSENTIAL PURPOSE, AND WHETHER OR NOT SMSC HAS BEEN ADVISED OF THE POSSIBILITY OF SUCH DAMAGES.

General Description

The EMC6D103 is an environmental monitoring device with automatic fan control capability. This ACPI compliant device provides hardware monitoring for up to five voltages and three thermal zones, measures the speed of up to four fans, and controls the speed of multiple DC fans using Pulse Width Modulator (PWM) outputs. High frequency and low frequency PWMs are supported.

The EMC6D103 hardware monitor provides analog inputs for monitoring external voltages of +2.5V, +5V, +12V and V_{ccp}. This device has the capability to monitor its own internal VCC power supply, which may be connected to either main power (VCC) or the suspend power well (VTR). In addition to monitoring the processor voltage, VID inputs are available to identify the voltage specification. External components are not required for voltage scaling or similar treatment.

The EMC6D103 hardware monitor includes support for monitoring three thermal zones: two external and one internal. The external temperatures are measured via thermal diode inputs capable of monitoring remote devices. In addition, they are equipped with an ambient temperature sensor for measuring the internal temperature.

Pulse Width Modulators (PWM) control the speed of the fans by varying the output duty cycle of the PWM. Each PWM can be associated with any or all of the thermal zones monitored. As the temperature of the associated zone varies, the PWM duty cycle is adjusted accordingly. The Ramp Rate Control feature controls the rate of change of the PWM output, thereby reducing system noise created by changing the fan speed. The speed of each fan is monitored by a Fan Tachometer input. The measured values are compared to values stored in Limit Registers to detect if a fan has stalled or seized.

Fan speed may be under host software control or automatic. In host control mode, the host software continuously monitors temperature and fan speed registers, makes decisions as to desired fan speed and sets the PWM's to drive the required fan speed. This device offers an interrupt output signal (INT#), which may be used to interrupt the host on out-of-limit temperature or voltage condition enabling an ACPI response as opposed to the host software continuously monitoring status. In auto "zone" mode, the logic continuously monitors the temperature and fan speeds and adjusts speeds without intervention from the host CPU. Fan speed is adjusted according to an algorithm using the temperature measured in the selected zone, the high and low limits set by the user, and the current fan speed.

The EMC6D103 supports two Monitoring modes: Continuous Mode and Cycle Mode. In the continuous monitoring mode, the sampling and conversion process is performed continuously for each voltage and temperature reading after monitoring is enabled. The time for each voltage and temperature reading varies depending on the measurement option. In cycle monitoring mode, the part completes all sampling and conversions, then waits approximately one second to repeat the process. It repeats the sampling and conversion process typically every 1.2 seconds (1.4 sec max - default averaging enabled). The sampling and conversion of each voltage and temperature reading is performed once every monitoring cycle. (This is a power saving mode.)

The EMC6D103 can be placed in one of two low-power modes: Sleep mode or Shutdown mode. These modes do not reset any of the registers of the device. In Sleep mode bias currents are on and the internal oscillator is on, but the the A/D converter and monitoring cycle are turned off. Serial bus communication is still possible with any register in the Hardware Monitor Block while in this low-power mode. In Shutdown mode the bias currents are off, the internal oscillator is off, and the the A/D converter and monitoring cycle are turned off. Serial communication is only possible with a select register.

Pin Configuration

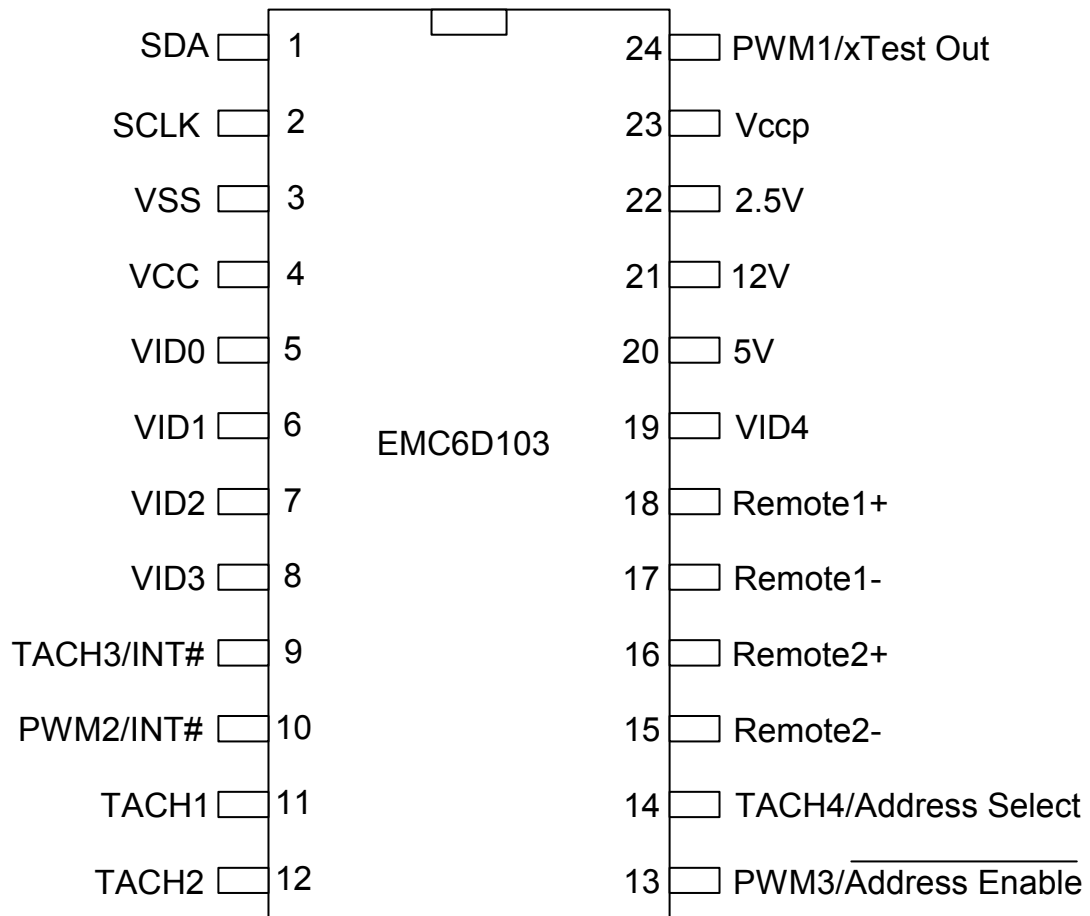

Figure 1 EMC6D103 Pin Configuration

Package Outline

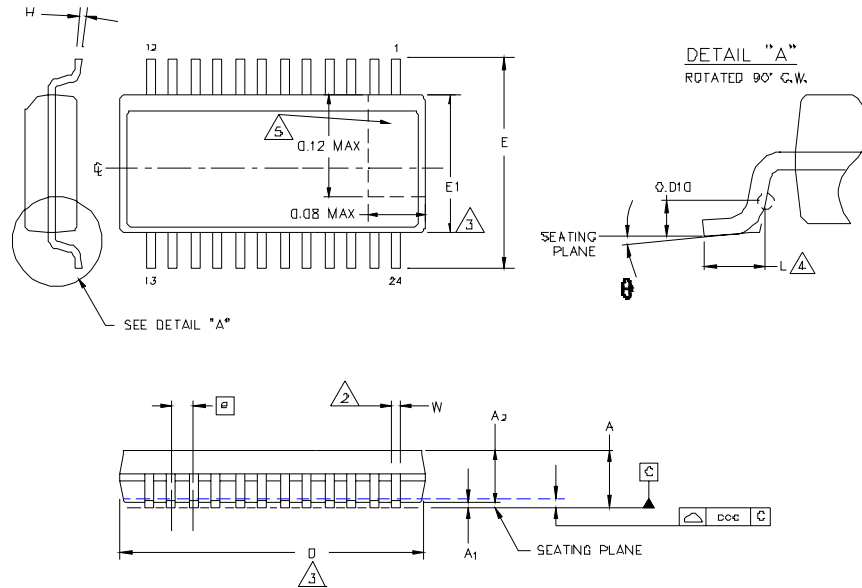

Figure 2 24-Pin SSOP Package Outline, 0.150” Wide Body, 0.025” Pitch

Table 1 24-Pin SSOP Package Parameters

	MIN	NOMINAL	MAX	REMARKS
A	0.053	~	0.069	Overall Package Height
A1	0.004	~	0.010	Standoff
A2	~	~	0.061	Body Thickness
D	0.337	~	0.344	X Body Size
E	0.228	~	0.244	Y Span
E1	0.150	~	0.157	Y body Size
H	0.007	~	0.010	Lead Frame Thickness
L	0.016	0.025	0.050	Lead Foot Length
e	0.025 Basic			Lead Pitch
è	0°	~	8°	Lead Foot Angle
W	0.008	0.010	0.012	Lead Width
ccc	~	~	0.004	Coplanarity

Notes:

1. Controlling Unit: inch.
2. Tolerance on the true position of the leads is ± 0.0035 inches maximum.
3. Package body dimensions D and E1 do not include the mold protrusion. Maximum mold protrusion is 0.006 inches for ends, and 0.010 inches for sides.
4. Dimension for foot length L measured at the gauge plane 0.010 inches above the seating plane.
5. Details of pin 1 identifier are optional but must be located within the zone indicated.