

2.4GHz 802.11ac Front End Module

Description

The LX5584B is a complete integrated 2.4GHz Front-End Module (FEM) for an IEEE 802.11ac system. It includes a highly linear 2.4GHz Power Amplifier (PA) with power detector, Low Noise Amplifier (LNA) with bypass capability, and SP3T antenna switch. This highly integrated FEM reduces the system footprint, bill of materials, and manufacturing cost.

The LX5584B is available in a 16-pin 3 mm x 3 mm QFN Package.

Features

- 5V Supply Voltage
- Integrated 2.4GHz PA, LNA, and SP3T Tx/Rx/BT Switch
- $P_{OUT} = 20\text{dBm}$ (256QAM/40MHz)
- Bypassable Low Noise Figure LNA
- 3 mm x 3 mm QFN package
- RoHS2 Compliant & Halogen Free

Applications

- Tablets
- Access Points
- Mobile Devices
- Notebooks
- Gaming

Block Diagram

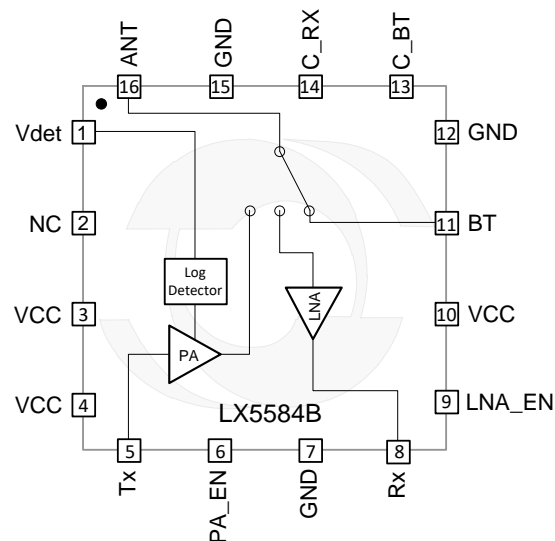

Figure 1 - Functional Block Diagram

Pin Configuration

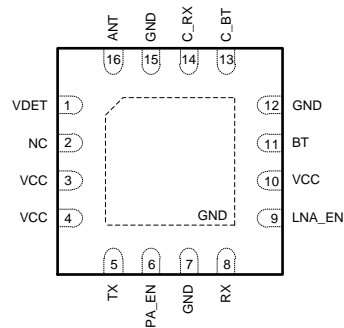

Figure 2 · Pinout (Top View)

Ordering Information

Ambient Temperature	Type	Package	Ordering Part Number	Packaging Type
-40°C to 85°C	RoHS2 compliant, Pb-free NiPdAu lead finish	QFN 3x3x0.9 16L	LX5584BLQ-TR	Tape and Reel

Pin Description

Pin Number	Pin Designator	Description
1	VDET	Output of transmit power detector
2	NC	No connect
3	VCC	5 V nominal supply voltage
4	VCC	5 V nominal supply voltage
5	Tx	RF is 50 Ohm input to PA. DC is shorted to GND.
6	PA_EN	Power amplifier digital enable
7	GND	Ground
8	Rx	DC blocked 50ohm output of bypassable LNA
9	LNA_EN	LNA digital enable
10	VCC	5 V nominal supply voltage
11	BT	Bluetooth port

Pin Number	Pin Designator	Description
12	GND	Ground
13	C_BT	Bluetooth control pin
14	C_RX	Receiver control pin
15	GND	Ground
16	ANT	DC blocked 50 ohm antenna port

Absolute Maximum Ratings

Parameter	Value	Units
DC Supply Voltage (VCC)	5.5	V
Control Inputs (PA_EN, LNA_EN, C_RX, C_BT)	3.6	V
CW or OFDM Input Power at TX Port	+5	dBm
Maximum Junction Temperature (T _{JMAX})	+150	°C
Operational Ambient Temperature	-40 to +85	°C
Storage Temperature Range	-65 to +150	°C
Peak Package Solder Reflow Temperature (30 seconds maximum exposure)	260	°C
Electrostatic Discharge Human Body Model (HBM), Class 1B	500	V

Note: Although this device is designed to be as robust as possible, Electrostatic Discharge (ESD) can damage this device. This device must be protected at all times from ESD. Static charges may easily produce potentials of several kilovolts on the human body or equipment, which can discharge without detection. Industry-standard ESD precautions should be used at all times.

Exceeding any Absolute Maximum ratings could cause damage to the device. All voltages are with respect to GND. Currents are positive into, negative out of specified terminal. These are stress ratings only and functional operation of the device at these or any other conditions beyond those indicated under “Recommended Operating Conditions” are not implied. Exposure to “Absolute Maximum Ratings” for extended periods may affect device reliability.

Thermal Properties

Thermal Resistance	Typ	Units
θ_{JP} Junction to Pad	10.4	°C/W
θ_{JA} Junction to Ambient	44.1	

Note: The θ_{Jx} numbers assume no forced airflow. Junction Temperature is calculated using $T_J = T_A + (\text{Power dissipation} \times \theta_{JA})$ or $T_J = T_P + (\text{Power dissipation} \times \theta_{JP})$. In particular, θ_{JA} is a function of the PCB construction. The stated number above is for a four-layer board in accordance with JESD-51 (JEDEC).

Electrical Characteristics - General

$V_{CC}=5.0V$, $T_A=25^\circ C$ unless otherwise specified.

Symbol	Parameter	Test Condition	Min	Typ	Max	Units
General Characteristics						
VCC	Supply Voltage VCC		4.75	5	5.25	V
F _{RF}	Frequency Range		2.402		2.482	GHz
BW _{CN}	Channel Bandwidth		20		40	MHz
V _{IH}	Control Logic Levels		3	3.3	3.6	V
V _{IL}			0		0.4	V
I _{CTRL}	Control Current	3.3V logic level		10		uA
Δt_{onPA} Δt_{offPA}	Rx→Tx Switching Time	Difference between falling edge of LNA_EN and time when Tx output has settled to within 90% of its final power.		500		nsec
Δt_{rxlvl}	Rx Gain Switching Time	Difference between edge of LNA_EN and time when Rx output has settled to within 90% of its final power.		100		nsec
Δt_{onLNA} , Δt_{offLNA}	Tx→Rx Switching Time	Difference between edge of PA_EN and time when Rx output has settled to within 90% of its final power.		500		nsec
T _{oper}	Operating temperature range	Case temperature	-40		85	°C
Ru	Ruggedness	P _{IN} = 5 dBm VSWR = 6:1 802.11n	No damage			

Electrical Characteristics - Detector

V_{CC}=5.0V, T_A=25°C unless otherwise specified.

Symbol	Parameter	Test Condition	Min	Typ	Max	Units
Detector Characteristics						
PD _{RANGE}	Power detector range		5		24	dBm
PD _{SENS}	Power Detector Sensitivity	V _{det} RMS Sensitivity measured during the first 16μs of the preamble		25		mV/dB
PD _{FREQ}	Power Detector Variation Over Frequency	V _{det} RMS variation (Max-Min) At any particular detector voltage, and at any particular supply voltage and temperature, the measured RF output power variation over the sub-band must fall within the limits shown.			1	dB
PD _{VFT}	Power detector variation over supply, process, and temperature	V _{DET} RMS variation (Max-Min) At any particular detector voltage, the measured RF output power variation over P, V, and T must fall within the limits shown.			2	dB
PD _{BW}	Power Detector Variation Over Channel Bandwidth	V _{DET} RMS variation (Max-Min) At any particular detector voltage, the measured RF output power variation over all channel bandwidths.			2	dB
V _{DET}	Power Detector Voltage	DC detector volatage No RF input		300		mV
		RMS detector volatage P _{OUT} = 24 dBm Measured in first 16μs of preamble		910		
Z _{DET}	Detector Output Impedance			2.4		kΩ

Electrical Characteristics - Transmit

V_{CC}=5.0V, T_A=25°C unless otherwise specified.

Symbol	Parameter	Test Condition	Min	Typ	Max	Units
Tx Characteristics						
RL _{TXIN}	Input Return Loss	TxA port with PA enabled		10		dB
RL _{TXOUT}	Output Return Loss	ANT port with PA enabled		10		dB
GAIN _{TX}	Power Gain	Signal gain in operating frequency band.		33		dB
ΔGAIN _{TX}	Power Gain Variation	Over single 40MHz-channel		0.4		dB
		Over entire band		1		
P _{LIN}	Linear Output Power	802.11ac, VHT40, MCS9 Dynamic EVM < -35 dB		20		dBm
		802.11n, HT20, MCS7 Dynamic EVM < -30dB		21		
DEVM _{FLOOR}	Dynamic EVM floor	5 < P _{OUT} < 16dBm 802.11ac, VHT40, MCS9		-40		dB
MASK	Spectrum Emission Mask Compliant Power	802.11b, 1 Mbps, Root Cosine		23		dBm
HD2	2 nd harmonic	P _{OUT} = 23 dBm Freq = 2.412, 2.437, 2.472GHz 802.11b 1Mbps		-20		dBm/MHz
HD3	3 rd Harmonic	P _{OUT} = 23 dBm Freq = 2.412, 2.437, 2.472GHz 802.11b 1Mbps		-40		dBm/MHz
I _{CC}	Operating Current	P _{OUT} = 20 dBm		230		mA
		P _{OUT} = 23 dBm		305		
I _{CQ, TX}	Quiescent Current	No RF input. PA enabled		130		mA

Electrical Characteristics - Receive

V_{CC}=5.0V, T_A=25°C unless otherwise specified.

Symbol	Parameter	Test Condition	Min	Typ	Max	Units
Rx Characteristics						
RL _{RXIN}	Input Return Loss	At Ant port for HG states		15		dB
		At Ant port for bypass Rx states		10		
RL _{RXOUT}	Output Return Loss	At Rx port All RX gain states		15		dB
GAIN _{RX}	Small Signal Gain	LNA enabled		13		dB
		LNA bypass state (bypass)		-8		
ΔGAIN _{RX}	Small Signal Gain Variation	Over single 40MHz-channel		0.5		dB
		Over entire F _{RF}		1		
G _{STEP}	Gain step	Gain difference between HG and bypass		21		dB
NF	Noise Figure	LNA enabled, 25°C		2.8		dB
IIP3	Input Third Order Intercept Point	At ANT port with LNA enabled. To be measured with total input power = -10dBm (-13 dBm/tone).		7		dBm
		At ANT port with LNA bypassed. Measured with total input power = 5 dBm (2dBm/tone).		35		
I _{CQ,RX}	Operating Current	LNA enabled No RF input		10		mA

Electrical Characteristics - Bluetooth

V_{CC}=5.0V, T_A=25°C unless otherwise specified.

Symbol	Parameter	Test Condition	Min	Typ	Max	Units
BT Characteristics						
RL _{BTIN}	Input Return Loss	At ANT port Mode = BT		10		dB
RL _{BTOUT}	Output Return Loss	At BT port Mode = BT		15		dB
IL _{BT}	Insertion Loss	ANT to BT port Mode = BT		1.5		dB

When BT port is not used, it must be terminated with 50Ohm load.

Functional State Table

PAEN	LNAEN	C_Rx	C_BT	Default State
0	0	0	0	Sleep mode
1	0	0	0	PA Enabled
0	1	1	0	LNA Enabled, High gain mode
0	0	1	0	LNA Bypassed
0	0	0	1	Bluetooth

¹ Logic HI / LOW voltage ranges are as defined previously.

² All control signals must be driven. Operation Mode is undefined if any control signal is floating.

Part Markings

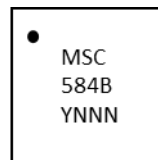

- Pin 1 identifier
- MSC Company name
- 584B Part number
- YNNN Trace code

Figure 3 · Typical Part Markings

Package Outline Dimensions

The package is halogen free and meets RoHS2 and REACH standards.

(MSL1, 260°C per JEDEC J-STD-020)

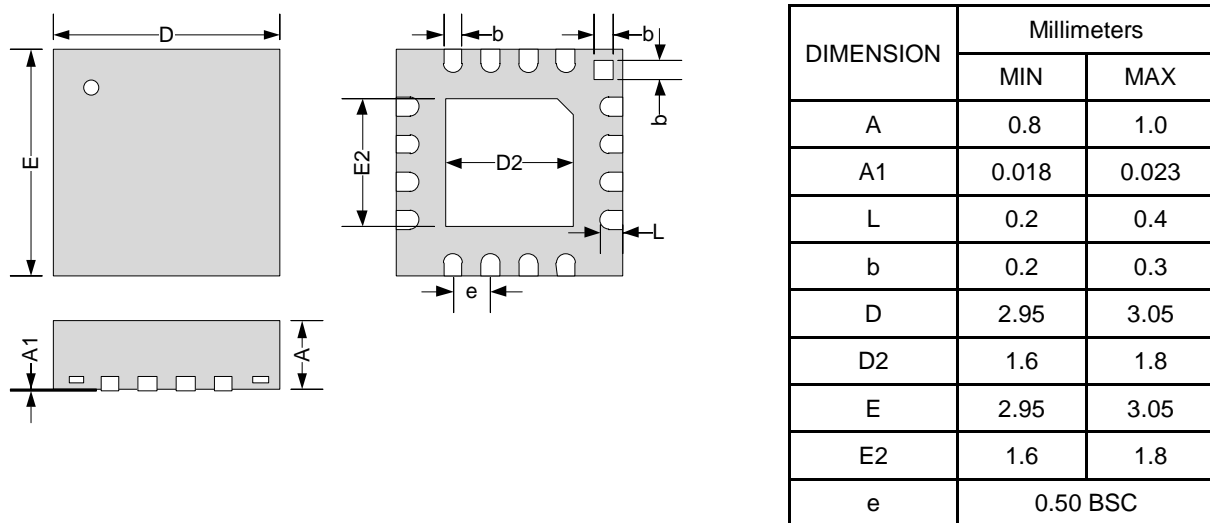
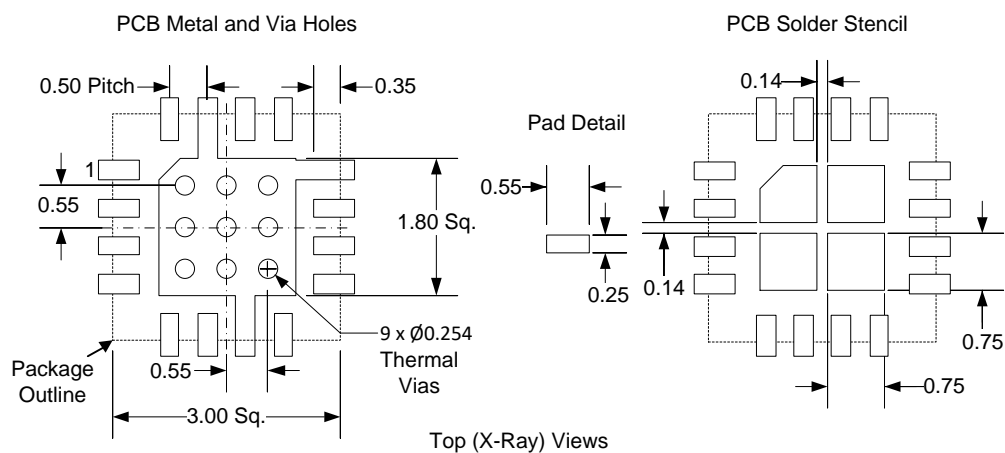

Figure 4 • 16 Pin QFN Package Dimensions



Notes:

1. All dimensions are in millimeters.
2. Unless specified dimensions are symmetrical about center lines.
3. OSP or NiAu planar surface finish recommended.
4. Non-Solder Mask Defined (NSMD) pads recommended for terminal pads.
5. Recommended tented thermal vias as shown with vias filled with solder.
6. Stencil thickness < 0.15mm.
7. Aperture design for thermal pads using multiple openings with 60 to 80% solder paste coverage.

Figure 5 • PCB Layout Footprint (Top View)

Evaluation Board Schematic

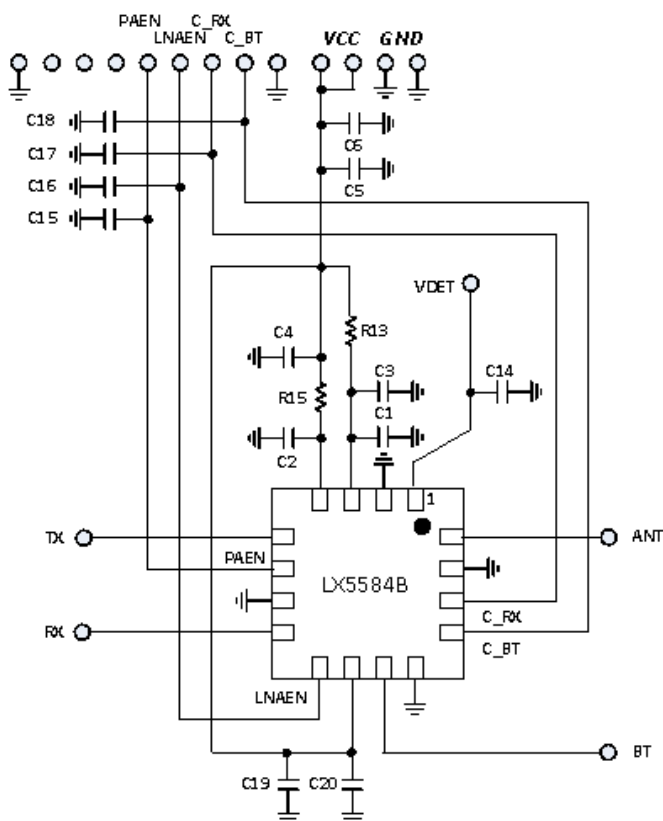

Figure 6 - Evaluation Board Schematic

Evaluation Board BOM

Part Number	Value	Package Size	Component
GRM1555C1H100JZ01D	10pf	0402	C1,C2
GRM1555C1H120FA01D	12pf	0402	C14, C15
GRM1555C1H101JZ01D	100pf	0402	C20
GRM1555C1H471JA01D	470pf	0402	C16,C17,C18
GRM155R60J105KE19D	1uf	0402	C3, C4, C19
GRM188R71A105KA61D	1uf	0603	C5
F981C475MMA	4.7uf	0603	C6
ERJ-3BQJ2R7V	2.7 ohm	0603	R13
ERJ-2RKf10R0X	10 ohm	0402	R15



Microsemi Corporate Headquarters
One Enterprise, Aliso Viejo,
CA 92656 USA

Within the USA: +1 (800) 713-4113
Outside the USA: +1 (949) 380-6100
Sales: +1 (949) 380-6136
Fax: +1 (949) 215-4996

E-mail: sales.support@microsemi.com

© 2019 Microsemi Corporation. All rights reserved. Microsemi and the Microsemi logo are trademarks of Microsemi Corporation. All other trademarks and service marks are the property of their respective owners.

Microsemi Corporation (Nasdaq: MSCC) offers a comprehensive portfolio of semiconductor and system solutions for communications, defense & security, aerospace and industrial markets. Products include high-performance and radiation-hardened analog mixed-signal integrated circuits, FPGAs, SoCs and ASICs; power management products; timing and synchronization devices and precise time solutions, setting the world's standard for time; voice processing devices; RF solutions; discrete components; security technologies and scalable anti-tamper products; Power-over-Ethernet ICs and midspans; as well as custom design capabilities and services. Microsemi is headquartered in Aliso Viejo, Calif., and has approximately 3,400 employees globally. Learn more at www.microsemi.com.

Microsemi makes no warranty, representation, or guarantee regarding the information contained herein or the suitability of its products and services for any particular purpose, nor does Microsemi assume any liability whatsoever arising out of the application or use of any product or circuit. The products sold hereunder and any other products sold by Microsemi have been subject to limited testing and should not be used in conjunction with mission-critical equipment or applications. Any performance specifications are believed to be reliable but are not verified, and Buyer must conduct and complete all performance and other testing of the products, alone and together with, or installed in, any end-products. Buyer shall not rely on any data and performance specifications or parameters provided by Microsemi. It is the Buyer's responsibility to independently determine suitability of any products and to test and verify the same. The information provided by Microsemi hereunder is provided "as is, where is" and with all faults, and the entire risk associated with such information is entirely with the Buyer. Microsemi does not grant, explicitly or implicitly, to any party any patent rights, licenses, or any other IP rights, whether with regard to such information itself or anything described by such information. Information provided in this document is proprietary to Microsemi, and Microsemi reserves the right to make any changes to the information in this document or to any products and services at any time without notice.