

# Le79271 SLIC

## Subscriber Line Interface Circuit Next Generation Carrier Chipset (NGCC)

### APPLICATIONS

- **Cost-effective voice solution for long or short loops providing POTS and integrated test capabilities**
  - IVD
  - CO, DLC
  - Voice-enabled DSLAM
  - PBX/KTS
  - MDU, MSAP, MSAN

### FEATURES

- **Designed to minimize POTS transients, optimizing CRC performance for triple play applications**
- **Best-in-class GR-844 equivalent testing**
  - Fully validated test primitives and host routines
  - Guaranteed performance parameters
- **Optimized for best-in-class density**
- **Monitor of two-wire interface voltages and currents supports:**
  - Voice transmission
  - Internal ringing generation
  - Programmable DC feed characteristics
    - Current limited and independent of battery
  - Selectable off-hook and ground-key thresholds
  - Subscriber line diagnostics
    - Leakage and loop resistance
    - Line capacitance and bell capacitance
    - Foreign voltage sensing
  - Power cross and fault detection
- **Supports 85 Vrms internal ringing**
  - Supports balanced and unbalanced ringing
- **3.3 V and battery supplies**
  - Supports two negative and one positive battery
- **Dual battery operation for system power saving**
  - Automatic battery switching
  - Intelligent thermal management
- **Compatible with inexpensive protection networks**
- **Metering capable**
  - 12 kHz and 16 kHz
  - Smooth polarity reversal
- **Tip-open mode supports ground start signaling**
- **Integrated test load switch**
- **5 REN with DC offset**

### FEATURES WITH LE79124 NGVCP

- 72 channel call aggregation
- GR-844 equivalent line testing

### ORDERING INFORMATION

An Le79238 or ZL79258 SLAC device must be used with this part.

Device	Package Type (Green) <sup>1</sup>	Packing <sup>2</sup>
Le79271MQC	28-Pin QFN	Tray
Le79271AMQC	28-Pin QFN	Tray

1. The green package meets RoHS Directive 2002/95/EC of the European Council to minimize the environmental impact of electrical equipment.
2. For delivery using a tape and reel packing system, add a "T" suffix to the OPN (Ordering Part Number) when placing an order.

### DESCRIPTION

The Le79271 (and higher longitudinal balance Le79271A) Next Generation Subscriber Line Interface Circuit (SLIC) device in combination with a SLAC device, implement a DSL friendly, high density universal telephone line interface. This enables the design of a low cost, high performance, fully software programmable line interface with worldwide applicability. All AC, DC, and signaling parameters are programmable. Additionally, the NGCC has integrated self-test and line-test capabilities to resolve faults to the line or line circuit.

### RELATED LITERATURE

- 126583 NGCC Hardware Design Guide
- 128623 NGCC Designer's Guide
- 081193 Le79238 Octal NGSLAC Device Data Sheet
- 136868 ZL79258 Octal NGSLAC Device Data Sheet
- 081567 Le79124 NGVCP Device Data Sheet
- 133514 Le79234 NGVCP Device Data Sheet

### BLOCK DIAGRAM

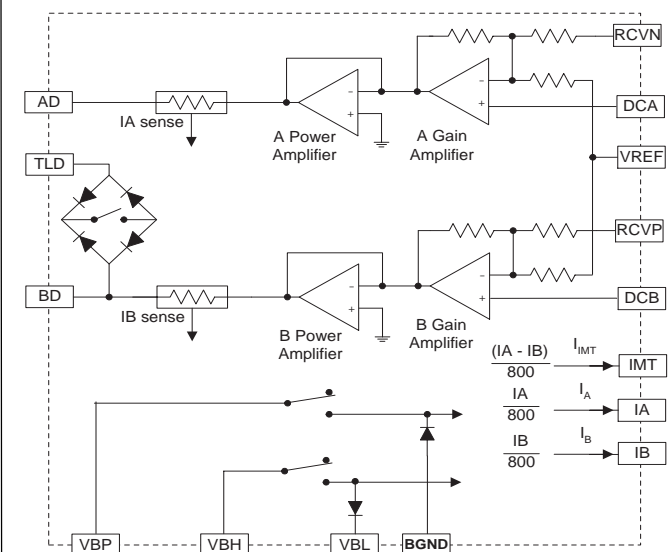

## Table of Contents

<b>Applications</b> .....	1
<b>Features</b> .....	1
<b>Features With Le79124 NGVCP</b> .....	1
<b>Ordering Information</b> .....	1
<b>Description</b> .....	1
<b>Related Literature</b> .....	1
<b>Block Diagram</b> .....	1
<b>Product Description</b> .....	3
Next Generation VCP Features .....	4
Features of the NGCC .....	6
<b>NGCC with Next Generation VCP Device</b> .....	7
<b>NGCC Block Diagram - Eight Channel Line Card Example</b> .....	7
<b>Connection Diagram</b> .....	8
<b>Pin Descriptions</b> .....	9
<b>Electrical Characteristics</b> .....	10
Absolute Maximum Ratings .....	10
Thermal Resistance .....	10
Electrical Operating Ranges .....	11
<b>Specifications</b> .....	11
Power Dissipation .....	11
Supply Currents .....	12
DC Specifications .....	13
Transmission Specifications .....	15
Test Switch Specifications .....	16
Thermal Shutdown Fault Indications .....	16
Data Friendly Transient Specifications .....	17
<b>Operating Modes</b> .....	18
Operating Mode Descriptions .....	19
<b>Timing Specifications</b> .....	20
<b>Waveforms</b> .....	20
<b>Physical Dimensions</b> .....	21
28-Pin QFN .....	21
<b>Revision History</b> .....	22
Version 8 to 9 .....	22
Version 9 to 10 .....	22
Version 10 to 11 .....	22
Version 11 to 12 .....	22
Version 12 to 13 .....	22

## PRODUCT DESCRIPTION

Microsemi's Next Generation Carrier Chipset (NGCC) integrates all functions required to interface to a subscriber line. Two chip types are used to implement the line card — a SLIC device and a SLAC device. These provide the following basic functions:

1. The Le79271 or Le79271A SLIC device: A high voltage, bipolar device that drives the subscriber line and senses line conditions. These devices are single channel devices (one channel per package). The SLIC device is available in two grades of longitudinal balance (refer to Item #14 in Table 4). The Le79271A is identical to the Le79271 for all other parameters.
2. The Le79238 or ZL79258 Octal SLAC device: Low voltage CMOS IC that provides conversion, control and DSP functions for eight Le79271 devices and senses line conditions. The Le79238 supports internal ringing, the ZL79258 supports both internal and external ringing.

The SLIC device uses reliable, bipolar technology to provide the power necessary to drive a wide variety of subscriber lines. It is controlled by the SLAC device to operate in different modes that control power consumption and signaling. The Le79271 device is designed to be used exclusively with the Le79238 or ZL79258 SLAC device. The SLIC device requires only VCC and the battery supplies for its operation.

The SLIC device functions as the interface between the low-voltage SLAC device and the high-voltage POTS loop. The basic SLIC architecture is voltage feed and current sense. In the 4-Wire to 2-Wire (receive) direction it provides two gain paths to the POTS loop (A & B Leads). One path is used to feed DC and ringing signals to the loop. The second is used to feed AC transmission and PPM signals to the loop. The drive amplifiers can deliver at least  $\pm 120$  mA to the loop for the transmission, DC feed and ringing signals. In the 2-Wire to 4-Wire (transmit) direction the SLIC senses the AC and DC current in the loop and translates these currents into signals that are compliant with the low-voltage circuitry in the SLAC. It passes three currents to the SLAC — one current equal to the A-Lead current divided by 800, one current equal to the B-Lead current divided by 800, and one current equal to the A-Lead current minus the B-Lead current divided by 800 (the loop metallic current divided by 400). The SLIC provides no signal processing other than gain and level conversion for these transmit and receive signals. Any signal processing required to support the Le79271 feature set is provided by the SLAC device and associated digital processor.

The SLIC device provides the necessary high-voltage functions that the SLAC device cannot implement using low-voltage signal processing. The SLIC device has a normal operating mode (for transmission, supervision, etc.), a Tip Open mode (high impedance A-Lead), a Ring Open mode (high impedance B-Lead) and a Disconnect mode (high impedance A-Lead and B-Lead). The normal, Tip Open and Ring Open modes are available with either standard or low-power (for power conservation) biasing. The functionality of each mode in low-power biasing is identical to standard biasing, except that some operational limits and/or accuracies may be reduced. The standard biasing modes are Active (normal transmission, DC feed, supervision and ringing), Tip Open Test and Ring Open Test; the low-power modes are Standby (reduced transmission, DC feed, supervision and ringing capability), Tip Open (ground start supervision) and Ring Open. Switching the SLIC from Active to Standby or from Standby to Active is designed not to create transients that could cause CRC errors in IVD applications, provided that the customer end is properly terminated. When the SLIC is programmed in any of the low-power modes, it will automatically switch to the corresponding standard mode when the current in either the A-Lead or B-Lead exceeds  $\sim \pm 15$  mA. In order to return to the low-power mode, the device must be reprogrammed via the latched data bus (P-bus (P0-P2, SEL)). All operating modes and switches are controlled by the SLAC device via the P-bus.

The SLIC device also provides two internal switches that connect the internal supply rails to alternative power supplies in order to minimize power consumption under various operating conditions. Switch operation is designed not to create transients that could cause CRC errors in IVD applications. The device also provides a switch that is used to connect the B-Lead to the A-Lead through an external resistor for line testing.

Thermal protection is provided internally to protect the device during fault conditions. When the device temperature exceeds a temperature threshold the thermal protection automatically places the drive amplifiers in the Disconnect mode and turns the Test Switch off. When the device cools, the thermal protection returns the device to the operating mode and switch configuration that it was in prior to thermal overload.

The SLIC device is designed to provide balanced and unbalanced ringing, with or without dc offset, to the subscriber loop.

The SLAC device contains high-performance circuits that provide A/D and D/A conversion for voice (codec/filter), DC-feed control, ringing, and supervision signals. The SLAC device contains a DSP core that handles signaling, DC-feed, supervision and line diagnostics for all eight channels. The DSP core also interfaces to a standard PCM/MPI backplane. These functions involve converting an analog voice signal into digital PCM samples and converting digital PCM samples back into an analog signal. During conversion, digital filters are used to band-limit the voice signals. The PCM codes can be 16-bit linear two's-complement with 8 kHz or 16 kHz sampling or 8-bit companded A-law or  $\mu$ -law.

The SLAC device provides a complete software configurable solution to the BORSCHT functions as well as complete programmable control over subscriber line DC-feed characteristics, such as current limit and feed resistance. In addition, the SLAC device provides extensive loop supervision capability including off-hook, ring-trip and ground-key detection. Detection thresholds for these functions are programmable. A programmable debounce timer is available that eliminates false detection due to contact bounce.

User-programmable filters include receive and transmit gain, transhybrid balance, two-wire termination impedance, and frequency attenuation (equalization) of the receive and transmit signals. All programmable digital filter coefficients can be calculated using WinSLAC™ software. This PC software allows the designer to enter a description of system requirements, WinSLAC™ then computes the necessary coefficients and plots the predicted system results.

The main functions that can be observed and/or controlled through the SLAC device backplane interface are:

- DC-feed characteristics
- Ground-key detection
- Off-hook detection
- Metering signal
- Longitudinal operating point
- Subscriber line voltage and currents
- Ring trip detection
- Abrupt and smooth battery reversal
- Subscriber line impedance matching
- Transmit and receive paths frequency response
- 4-wire to 2-wire hybrid impedance balance, or transhybrid loss
- DTMF detection (Q.24 compliant)
- Dial Pulse detection and decode
- Ringing signal generation
- Sophisticated line and circuit tests

Refer to the *Next Generation Carrier Chipset Hardware Design Guide (Document ID 126583)* for detailed Application Circuits and Parts Lists for various applications using the SLIC, SLAC, and VCP devices.

## Next Generation VCP Features

Optional Le79124 or Le79234 Next Generation Voice Control Processor (VCP) features provide the following solutions to the chip set:

- Provides expanded line and circuit testing in conjunction with Microsemi's NGCC
  - Le79271 SLIC device features extremely low leakage and tight gain tolerances for high accuracy measurements
- Aggregated call control lowers demand on host micro-processor
  - Le79124 — supports 72 channels of call aggregation
  - Le79234 — supports 32 channels of call aggregation
- Software interface using VoicePath™ API-II
- Software downloadable, field upgradeable, expandable
- Two Master SPI ports (Le79124)
- Two Slave PCM Highway ports
  - Single or dual PCM highways capable of operating up to 16.384 MHz
- Internal PLL and hardware network timing recovery for creating analog sampling clocks
- Real Time clock capable of being driven from the slave PCM clock
- Host controller interface options
- 32 General Purpose I/Os (Le79124)

Figure 1. Le79271 Device Internal Block Diagram

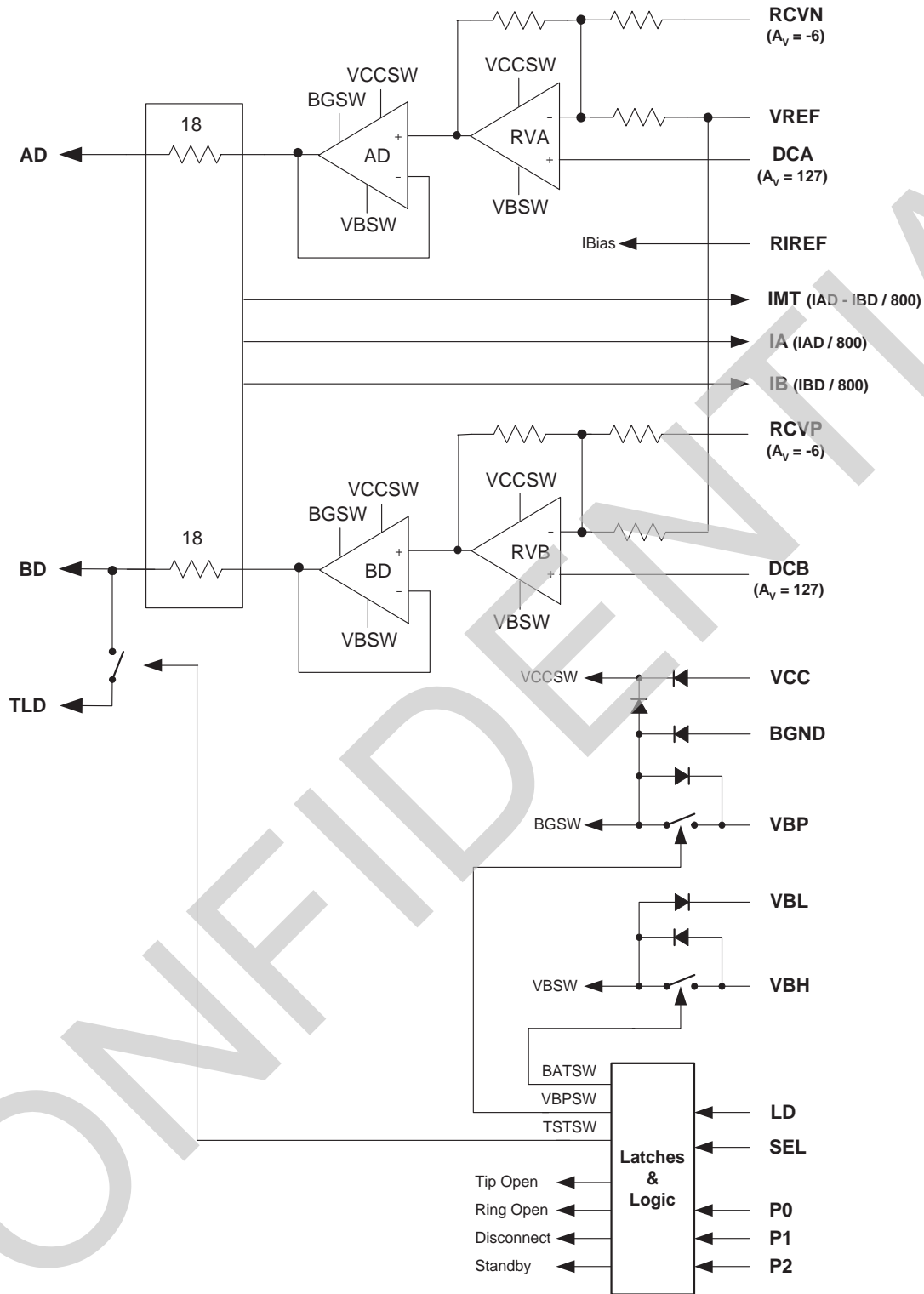

## Features of the NGCC

- Performs all battery feed, ringing, signaling, hybrid and test (BORSCHT) functions
- Controlled state changes to eliminate transients that could cause CRC errors
- Two or three chip solution supports high density, multi-channel architecture
- Supports two negative batteries and one positive battery
- Single hardware design meets multiple country requirements through software programming of:
  - Ringing waveform and frequency
  - DC loop-feed characteristics and current-limit
  - Loop-supervision detection thresholds
  - Off-hook debounce circuit
  - Ground-key and ring-trip filters
  - Off-hook detect de-bounce interval
  - Two-wire AC impedance
  - Transhybrid balance impedance
  - Transmit and receive gains
  - Equalization
  - Digital I/O pins
  - A-law/ $\mu$ -law and linear selection
- Supports wideband 7.0 kHz codec mode
- Supports internal ringing with DC bias
  - Programmed ringing cadence
  - Self-contained ringing generation and control
  - Integrated ring-trip filter and software enabled manual or automatic ring-trip mode
- Supports external ringing (with ZL79258 SLAC)
  - Controlled ringing entry and exit
- Supports metering generation with envelope shaping
  - Programmable metering cadencing
- Smooth polarity reversal
- Supports both loop-start and ground-start signaling
- SPI and PCM interfaces
- Exceeds LSSGR and CCITT central office requirements
- On-hook transmission
- Power/service denial mode
- Line-feed characteristics independent of battery voltage
- Low idle-power per line
- Compatible with inexpensive protection networks
- Monitors two-wire interface voltages and currents for subscriber line diagnostics
- Can monitor and/or drive A and B lead independently
- Automatic CID and Signaling and FSK and DTMF modes
- Tone generation
  - Howler
  - Call Progress
  - DTMF
- Modem support
- DTMF tone detection
- Dial Pulse and Flash detection
- Power-cross, fault, and foreign voltage detection
- Integrated line-test and self-test features
  - GR-909 and GR-844 equivalent
  - Built-in voice path test modes
  - 15 kHz noise filter
- Small physical size

**NGCC WITH NEXT GENERATION VCP DEVICE**

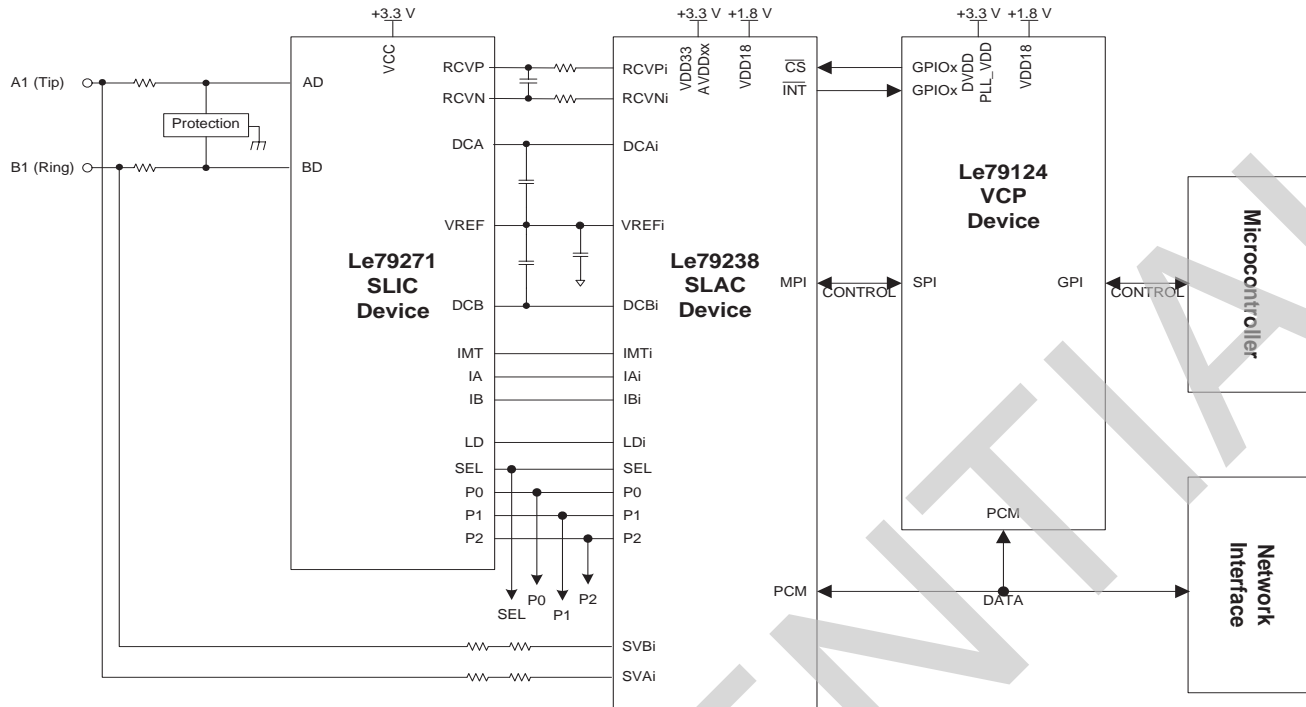

**NGCC BLOCK DIAGRAM - EIGHT CHANNEL LINE CARD EXAMPLE**

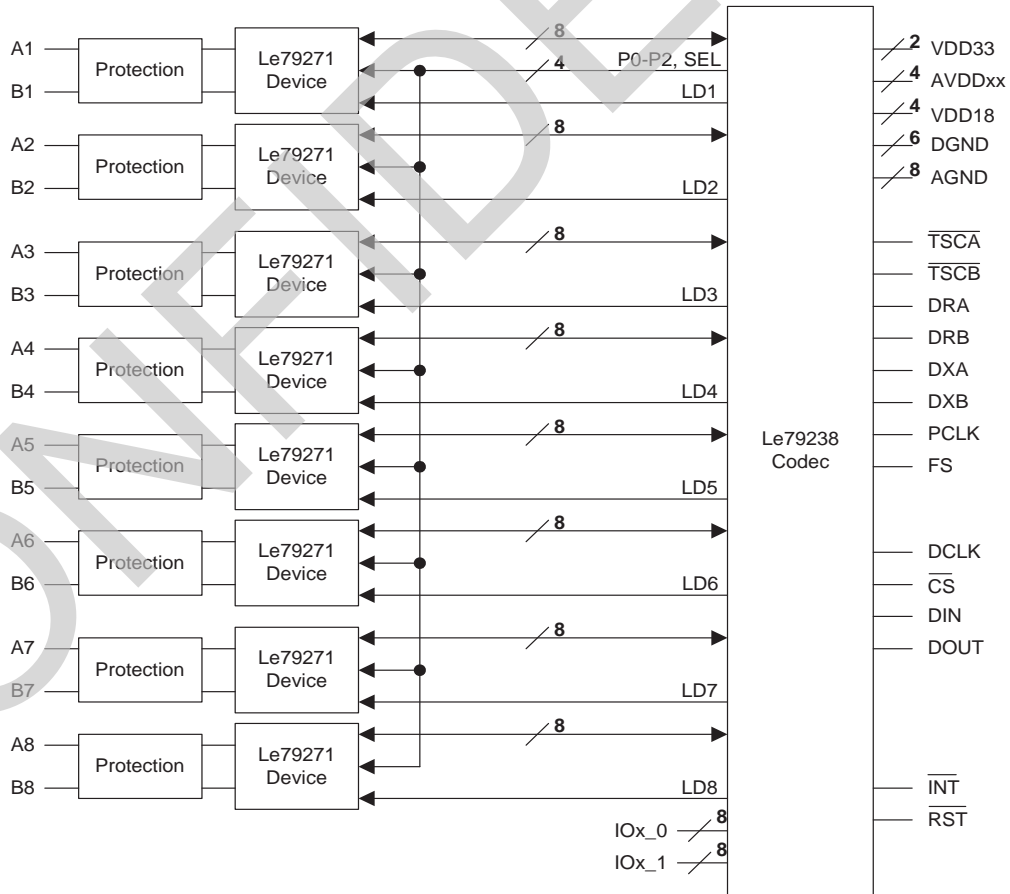

**CONNECTION DIAGRAM**

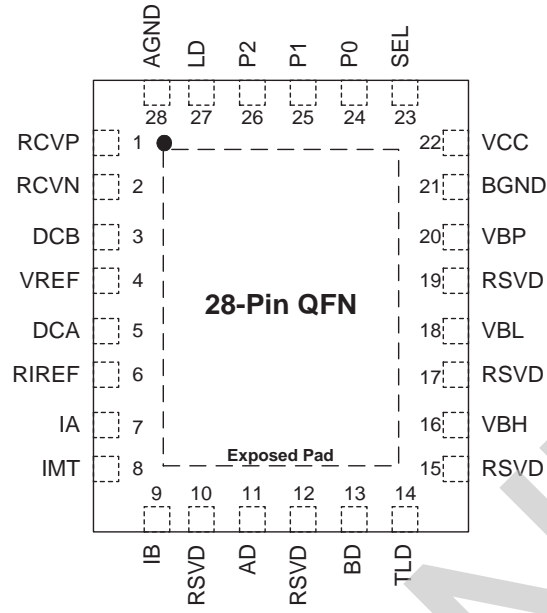

**TOP VIEW**

CONFIDENTIAL



## PIN DESCRIPTIONS

Pin Name	Pin #	Type	Description
AD, BD	11,13	Output	Provides the drive voltage to the A and B leads of the subscriber loop.
AGND	28	Ground	Analog ground return for VCC.
BGND	21	Ground	Ground return for the VBH, VBL and VBP battery supplies.
DCA	5	Input	The voltage on output AD is equal to VREF plus 127 times the difference of the voltage between DCA and VREF. This input is used to supply DC and ringing voltages to the A-Lead.
DCB	3	Input	The voltage on output BD is equal to VREF plus 127 times the difference of the voltage between DCB and VREF. This input is used to supply DC and ringing voltages to the B-Lead.
EPAD		Exposed Pad	Power dissipation pad - connect to BGND.
IA	7	Output	IA is proportional to the current in the AD lead (loop A-Lead current).
IB	9	Output	IB is proportional to the current in the BD lead (loop B-Lead current).
IMT	8	Output	IMT is proportional to the differential current in the AD and BD leads. Thermal overload is indicated by forcing IMT to AGND. This output is used to supply the metallic transmission (transmit) voltage from the loop.
LD	27	Input	Logic input that controls the data transfer into the data latches. When LD is Low, the data on inputs P0–P2 is transferred to the respective data latches as directed by the SEL pin. When LD is High, the data is locked in the latches.
P0–P2	24, 25, 26	Input	Logic inputs to the latches for the operating mode decoder and switches.
RCVN	2	Input	Receive AC Signal Input (Inverting). The voltage on output AD is equal to VREF minus 6 times the difference of the voltage between RCVN and VREF. This input, in conjunction with RCVP, is used to supply the metallic transmission voltage to the loop.
RCVP	1	Input	Receive AC Signal Input (Non Inverting). The voltage on output BD is equal to VREF minus 6 times the difference of the voltage between RCVP and VREF. This input, in conjunction with RCVN, is used to supply the metallic transmission voltage to the loop.
RREF	6	Input	External resistor connected from RREF to AGND sets the internal bias currents for the Le79271.
RSVD	10, 12, 15, 17, 19	Reserved	No connect pins necessary for voltage separation. May not be used as a tie point.
SEL	23	Input	Logic input that selects data inputs P0–P2 to either control the operating modes or the switches.
TLD	14	Output	Resistor connected from this pin to AD is connected from AD to BD when the Test Switch is programmed on.
VBH	16	Battery (Power)	High negative battery supply.
VBL	18	Battery (Power)	Low negative battery supply. Used to save power during Off-Hook for short loops. Connect directly to VBH if only one negative battery is available.
VBP	20	Battery (Power)	Positive battery supply. Used for ringing and very long loops. If positive supply is not used, connect this pin to BGND.
VCC	22	Power Supply	Positive 3.3V supply for low voltage analog and digital circuits.
VREF	4	Input	Reference voltage provided by the SLAC that the SLIC uses for an internal reference. Analog inputs RCVP, RCVN, DCA and DCB are referenced to this pin.

## ELECTRICAL CHARACTERISTICS

### Absolute Maximum Ratings

( $T_A = 23^\circ\text{C}$ )

Stresses greater than those listed under *Absolute Maximum Ratings* can cause permanent device failure. Functionality at or above these limits is not implied. Exposure to absolute maximum ratings for extended periods can affect device reliability.

Storage Temperature	-55 to +150°C
Ambient Temperature under Bias; Humidity	-40 to +85°C; 5% to 95%
VBP with respect to AGND	-0.4 to +110 V
VBH with respect to VBH	-0.4 to +160 V
VCC with respect to AGND	-0.4 to +4 V
VBH with respect to AGND	+0.4 to -150 V
VBL with respect to AGND	+0.4 to -80 V
VBL with respect to VBH	$ VBL  \leq  VBH  + 1 \text{ V}$ and $(VBL - VBH) < 90 \text{ V}$
BGND with respect to AGND	-3 to +3 V
Test Switch On-mode Current	100 mA
AD, BD and TLD: Continuous 10 ms (F = 0.1 Hz) 1 $\mu\text{s}$ (F = 0.1 Hz) 250 ns (F = 0.1 Hz)	VBH - 3 to VBP + 3 VBH - 5 to VBP + 5 VBH - 10 to VBP + 10 VBH - 15 to VBP + 15
Current through AD or BD	$\pm 150 \text{ mA}$
Digital Control Inputs to AGND	-0.4 to VCC + 0.4 V
ESD Immunity (Human Body Model)	JESD22 Class 1C compliant

### Thermal Resistance

Thermal resistance is discussed in the *Next Generation Carrier Chipset Hardware Design Guide*.

The thermal performance of a thermally enhanced package is assured through optimized printed circuit board layout. Specified performance requires that the exposed thermal pad be soldered to an equally sized exposed copper surface, which, in turn, conducts heat through multiple vias to a large internal copper plane.

### Package Assembly

Green package devices are assembled with enhanced, environmental compatible lead-free, halogen-free, and antimony-free materials. The leads possess a matte-tin plating which is compatible with conventional board assembly processes or newer lead-free board assembly processes. Refer to IPC/JEDEC J-Std-020 for recommended peak soldering temperature and solder reflow temperature profile.

## Electrical Operating Ranges

Microsemi guarantees the performance of this device over commercial (0°C to 70°C) and industrial (-40°C to 85°C) temperature ranges by conducting electrical characterization over each range and by conducting a production test with single insertion coupled to periodic sampling. These characterization and test procedures comply with the Telcordia GR-357-CORE Generic Requirements for Assuring the Reliability of Components Used in Telecommunications Equipment.

### Environmental Ranges

Ambient Temperature	-40 to +85 °C
Ambient Relative Humidity	15% to 85%

### Electrical Ranges

VCC*	+3.3 V ± 5%
VBL*	-15 to -80 V, with the constraint of $ VBL  \leq  VBH $
VBH*	-40 to -145 V
VBP*	AGND to +100 V
Maximum supply voltage across device, VBP - VBH	150 V
BGND with respect to AGND	-300 to +300 mV

\* If the power supply rails are floating before being connected to the power source (a typical hot insertion), no power-up sequencing is required, except to apply AGND and BGND first. However, if the power supply rails are switched or ramped from ground to their final operating voltages, VBH must be applied before VBL, or a diode must be included in series with the VBH supply in order to prevent reverse current flow from VBL to VBH.

## SPECIFICATIONS

### Power Dissipation

VBH = -48 V, VBL = -24 V, VCC = +3.3 V, VBP = +48 V

All power numbers are when on-hook with no loop current and no load.

**Table 1. Power Dissipation Specifications**

Operating Mode	Operating Condition	Test Condition	Min	Typ	Max	Unit
Disconnect	BATSW Off, VBPSW Off			8	15	mW
Standby	BATSW On, VBPSW Off			35	42	
Active	High Battery: BATSW On, VBPSW Off	Normal or Reverse Polarity		87	104	
	Low Battery: BATSW Off, VBPSW Off			47	58	
	Boosted Battery (Ringing): BATSW On, VBPSW On			187	217	
Tip Open	BATSW On, VBPSW Off			32	38	

## Supply Currents

$V_{BH} = -60\text{ V}$ ,  $V_{BL} = -36\text{ V}$ ,  $V_{CC} = +3.3\text{ V}$ ,  $V_{BP} = +60\text{ V}$

All supply currents are when on-hook with no loop current and no load.

Test conditions are the same as listed in Power Dissipation Specifications, [Table 1](#).

**Table 2. Supply Current Specifications**

Operating Mode	Operating Condition	Parameter	Min	Typ	Max	Unit
Disconnect	BATSW Off, VBPSW Off	$I_{VCC}$		2.3	3.0	mA
		$I_{VBH}$		0.1	20.0	$\mu\text{A}$
		$I_{VBL}$		27.0	100.0	$\mu\text{A}$
		$I_{VBP}$		1.0	20.0	$\mu\text{A}$
Standby	BATSW On, VBPSW Off	$I_{VCC}$		2.5	2.8	mA
		$I_{VBH}$		0.55	0.65	mA
		$I_{VBL}$		0.35	2.0	$\mu\text{A}$
		$I_{VBP}$		0.55	20.0	$\mu\text{A}$
Active, High Battery	BATSW On, VBPSW Off	$I_{VCC}$		4.5	5.0	mA
		$I_{VBH}$		1.5	1.8	mA
		$I_{VBL}$		0.27	2.0	$\mu\text{A}$
		$I_{VBP}$		0.6	20.0	$\mu\text{A}$
Active, Low Battery	BATSW Off, VBPSW Off	$I_{VCC}$		4.1	4.5	mA
		$I_{VBH}$		1.0	25.0	$\mu\text{A}$
		$I_{VBL}$		1.4	1.7	mA
		$I_{VBP}$		0.6	20.0	$\mu\text{A}$
Active, Boosted Battery (Ringing)	BATSW On, VBPSW On	$I_{VCC}$		1.30	1.65	mA
		$I_{VBH}$		1.5	1.9	mA
		$I_{VBL}$		0.35	2.0	$\mu\text{A}$
		$I_{VBP}$		2.3	2.5	mA
Tip Open	BATSW On, VBPSW Off	$I_{VCC}$		2.5	3.0	mA
		$I_{VBH}$		0.5	0.55	mA
		$I_{VBL}$		0.35	2.0	$\mu\text{A}$
		$I_{VBP}$		0.6	20.0	$\mu\text{A}$

## DC Specifications

Unless otherwise specified, test conditions are: VCC = +3.3 V, VBH = -60 V, VBL = -36 V, VBP = +60 V, Loop resistance (AD to BD) = On-Hook. For this document, currents flowing into a SLIC pin are defined as positive and currents flowing out of a SLIC pin are defined as negative. The specifications apply for Active and Standby operating modes with switches BATSW and VBPSW switched either ON or OFF. However, although the device meets the specifications in both modes, there may be a slight difference in the actual values between Active and Standby so that calibrating in one mode and testing in the other could result in measurement errors.

**Table 3. DC Specifications**

#	Item	Condition	Min	Typ	Max	Unit	Note
1	Gain DCA to AD	VAD / (VDCA - VREF)	125.7	127	128.3	V/V	
	Gain DCB to BD	VBD / (VDCB - VREF)	125.7	127	128.3	V/V	
2	(a) Gain RCVN to AD	VAD / (VRCVN - VREF)	-6.06	-6	-5.94	V/V	
	(b) Gain RCVP to BD	VBD / (VRCVP - VREF)	-6.06	-6	-5.94	V/V	
	RCV Gain Ratio	Ratio of 2(a) to 2(b)	0.995	1	1.005		
3	AD Offset	DCA = RCVN = VREF	-0.5		0.5	V	1
	BD Offset	DCB = RCVP = VREF	-0.5		0.5	V	1
4	Amplifier AD & BD Positive Saturation	I = 0 mA; VBPSW ON I = -40 mA; VBPSW ON I = -100 mA; VBPSW ON	VBP - 4.0 VBP - 4.5 VBP - 5.0		VBP	V	2
		I = 0 mA; VBPSW OFF I = -40 mA; VBPSW OFF I = -100 mA; VBPSW OFF	BGND BGND - 2.5 BGND - 3.0		+2.0 BGND BGND	V	
5	Amplifier AD & BD Negative Saturation	I = 0 mA; BATSW ON I = 40 mA; BATSW ON I = 100 mA; BATSW ON	VBH		VBH + 3.4 VBH + 3.8 VBH + 5.0	V	2
		I = 0 mA; BATSW OFF I = 40 mA; BATSW OFF I = 100 mA; BATSW OFF	VBL		VBL + 3.4 VBL + 3.8 VBL + 5.0	V	
6	AD & BD DC Feed Resistance (per pin)		15	18	21	Ω	
7	AD Pull-Up Current	Disconnect & Tip Open	0		50	μA	3
8	AD Voltage	Disconnect & Tip Open; 2 MΩ AD to VREF	-0.5		0	V	
9	BD Pull-Up Current	Disconnect & Ring Open	0		50	μA	3
10	BD Voltage	Disconnect & Ring Open; 2 MΩ BD to VREF	-0.5		0	V	
11	DCA & DCB Input Bias Current (per pin)	DCA = VREF ± 1.2 V DCB = VREF ± 1.2 V	-0.1	0	+0.1	μA	
12	RCVP & RCVN Input Bias Current (per pin)	RCVP = DCB RCVN = DCA	-1	0	+1	μA	
13	RCVP & RCVN Input Resistance (per pin)	RCVP = VREF ± 1.2 V RCVN = VREF ± 1.2 V	40		100	KΩ	
14	VREF Input Current	VREF = 1.5 V	-500		500	μA	4
15	Gain IA to IAD	IAD / IA; IAD from -100 mA to +100 mA	784	800	816	A/A	5
	Gain IB to IBD	IBD / IB; IBD from -100 mA to +100 mA	784	800	816	A/A	5
16	Gain IMT to (IAD - IBD)	(IAD - IBD) / IMT; (IAD - IBD) from -200 mA to +200 mA	784	800	816	A/A	5
17	IA, IB & IMT Voltage Compliance	VIA, VIB, VIAB	1.4	1.5	1.6	V	
18	IA output offset	IA = VREF; AD Open	-1	0	1	μA	
	IB output offset	IB = VREF; BD Open	-1	0	1	μA	

Table 3. DC Specifications (Continued)

#	Item	Condition	Min	Typ	Max	Unit	Note
19	IMT output offset	IMT = VREF; AD & BD Open	-2	0	2	μA	
20	IA, IMT Rejection Ratio	$\Delta I_A$ and $\Delta I_{MT}$ $\Delta V_{AD} = \pm 50$ V (-55 V to -5 V) with AD & BD Open		6.2		nA	
21	IB, IMT Rejection Ratio	$\Delta I_B$ and $\Delta I_{MT}$ $\Delta V_{BD} = \pm 50$ V (-55 V to -5 V) with AD & BD Open		10.6		nA	
22	Logic Inputs P0, P1, P2, SEL & LD	Input high voltage Input low voltage Input current	VCC/2 + 0.5  -50		VCC/2 - 0.5 50	V V μA	
23	IMT fault output	Thermal Overload	0		0.2	V	6

## Notes:

- Offset applies for any voltage at AD and BD, assuming amplifiers AD and BD are not saturated. In order to achieve these exact test conditions, VBPSW must be switched ON.
- Applies only to the amplifiers and switches and does not include the internal 18-Ω sense resistors.
- Positive voltage compliance for the leakage specification is VBP if VBPSW is ON and BGND if VBPSW is OFF. Negative voltage compliance is VBH if BATSW is ON and VBL if BATSW is OFF. When the switches are OFF the pin can be pulled by an external source to the maximum supply voltages, VBP (or VCC) and VBH, but the leakage current may increase up to the respective supply currents as defined by the operational mode of the SLIC.
- Varies depending on the voltages applied to DCA and DCB and thus may also have an AC component.
- If the SLIC is in the Standby mode, it automatically switches to the Active Mode when (IAD or IBD) exceeds  $\pm 15$  mA. In order to return to the Standby mode, the SLIC must be programmed via the P-bus. Positive voltage compliance on AD and BD is VBP if VBPSW is ON and BGND if VBPSW is OFF. Negative voltage compliance is VBH if BATSW is ON and VBL if BATSW is OFF. However, the gain accuracy may be degraded when AD or BD are within 2 V of either VBH or VBL and within 3 V of VBP.
- Not tested in production.

## Transmission Specifications

Unless otherwise specified, test conditions are:  $V_{CC} = +3.3\text{ V}$ ,  $V_{BH} = -60\text{ V}$ ,  $V_{BL} = -36\text{ V}$ ,  $V_{BP} = +60\text{ V}$ . There is a  $30\ \Omega$  protection resistor from AD to the loop A-Lead, a  $30\ \Omega$  protection resistor from BD to the loop B-Lead, and a  $600\ \Omega$  AC termination on the loop between the A-Lead and B-Lead (typical protection resistors are expected to be  $50\ \Omega$  but the worst case value is used here). There is a feedback path from output IMT to input pins RCVP and RCVN which creates a  $600\ \Omega$  AC terminating impedance. The feedback generates no noise, has no gain at DC and has a perfect trans-impedance gain of  $-33600\ \Omega$  from 50 Hz to 20 kHz. The feedback input (connected to IMT) is  $0\ \Omega$  referenced to 1.5 V and the output is a differential voltage source applied from RCVP to RCVN with a common mode voltage equal to VREF. The specifications apply for Active and Standby operating modes with switches BATSW and VBPSW switched either ON or OFF. However, although the device meets the specifications in both modes, there may be a slight difference in the actual values between Active and Standby so that calibrating in one mode and testing in the other could result in measurement errors. The specifications apply for any DC voltages on AD and BD that are within the operating voltage range as specified in Item #4 and Item #5 of DC Specifications and for any DC current in leads AD and BD from  $-100\text{ mA}$  to  $+100\text{ mA}$ .

**Table 4. Transmission Specifications**

Item #	Item	Condition	Min	Typ	Max	Unit	Note
1	AD or BD drive current = DC + longitudinal + signal + ringing current (per pin)	Active Mode	120	150		mApk	1
		Standby Mode	35	50			
2	Longitudinal impedance AD or BD to Ground		15	18	21	$\Omega$	1
3	Differential impedance AD to BD		30	36	42	$\Omega$	1
4	2-4 Wire gain	$(I_{AD} - I_{BD}) / \text{IMT}; f = 1\text{ kHz}$	784	800	816	A/A	
5	4-2 Wire gain	$(V_{AD} - V_{BD}) / (V_{RCVP} - V_{RCVN})$ $f = 1\text{ kHz}; \text{Loop Open AC}$	5.94	6	6.06	V/V	
6	2-4 Wire gain variation versus frequency	$f = 300\text{ to }3400\text{ Hz}$ Relative to 1 kHz	-0.1	0	+0.1	dB	1
7	2-4 Wire gain tracking	+3 dBm to -55 dBm Reference: -10 dBm, 1 kHz	-0.1	0	+0.1		
8	4-2 Wire gain variation versus frequency	$f = 300\text{ to }3400\text{ Hz}$ Relative to 1 kHz	-0.1	0	+0.1		
9	4-2 Wire gain tracking	+3 dBm to -55 dBm Reference: -10 dBm, 1 kHz	-0.1	0	+0.1		
10	Total harmonic distortion	0 dBm, 1 kHz, 600 $\Omega$ 2-Wire & 4-Wire			0.3	%	1
11	Metering Total Harmonic Distortion	Active Mode; $I_{\text{LOOP}} = 20\text{ mA}$ ; 2.8 Vrms, $f = 12\text{ kHz}$ or $16\text{ kHz}$ Metering Load = 200 $\Omega$ ,			1.0	%	1
12	Ringing Total Harmonic Distortion	Active Mode 75 Vrms, $f = 20\text{ Hz}$ or $50\text{ Hz}$ Ringing Load = 15 K $\Omega$ or 5 REN (1386 $\Omega$ + 40 $\mu\text{F}$ )		0.3	2.0	%	1
13	Idle channel noise	Active Mode: 2-Wire		9	13	dBrnC dBrnC0	1
		4-Wire		9	13		
		Active Mode: 2-Wire		-81	-77	dBmp dBmp0	
		4-Wire		-81	-77		
		Standby Mode: 2-Wire		15	19	dBrnC dBrnC0	
4-Wire		15	19				
2-Wire		-75	-71	dBmp dBmp0			
4-Wire		-75	-71				
		Active Mode with Metering 2.5 Vrms, $f = 12\text{ kHz}$ or $16\text{ kHz}$ 2-Wire			-65	dBmp	1

Table 4. Transmission Specifications (Continued)

Item #	Item	Condition	Min	Typ	Max	Unit	Note
14	Longitudinal to Metallic Balance (IEEE method)	Active Mode (Le79271) f = 200 to 1000 Hz f = 3000 Hz	58 56	66		dB dB	3, 6
		Active Mode (Le79271A) f = 200 to 1000 Hz f = 3000 Hz	64 59			dB dB	3, 6
		Standby Mode f = 200 to 1000 Hz f = 3000 Hz	52 50	58		dB dB	4, 6
15	Metallic to Longitudinal Balance (HARM)	Metallic to longitudinal (HARM) f = 200 to 3000 Hz	46			dB	5
16	VBH, VBL, VBP PSRR	f = 50 to 3400 Hz f = 3.4 to 50 kHz	40 25			dB	1
17	VCC PSRR	f = 50 to 3400 Hz f = 3.4 to 50 kHz	35 25			dB	1
18	BGND Rejection	f = 50 to 3400 Hz f = 3.4 to 50 kHz	50 30			dB	1
19	EMC, per ETSI EN 300 386 V1.3.1 (2001-09) and EN 61000-4-6	3 Vrms, f = 150 kHz – 80 MHz, 80% modulated with 1 kHz; 150 Ω common mode source impedance (300 Ω per leg)			-40	dBm	1

### Test Switch Specifications

Item	Condition	Min	Typ	Max	Unit	Note
Test Switch	ON Resistance; $(V_{ON(25mA)} - V_{ON(20mA)}) / 5 \text{ mA}$			30	Ω	
	ON Voltage; $I_{TLD} = \pm 20 \text{ mA}$	-3		3	V	
	OFF-Mode Leakage, VBP to VBH with VBP and VBH switches on			5	μA	

### Thermal Shutdown Fault Indications

Item	Condition	Min	Typ	Max	Unit	Description	Note
Thermal Overload	Temperature of power amplifiers AD and/or BD		190		°C	The device enters a 'disconnect like' mode that denies current to the loop (amplifiers AD and BD are shut down). Outputs IA and IB are both forced to source >150 μA. TSTSW operates normally	1, 2
Thermal Hysteresis	Temperature of power amplifiers AD and BD	20	30	40	°C	IA and IB return to normal operation, and the SLIC returns to the mode that it was in prior to thermal overload when the temperature of the amplifier (or amplifiers) in thermal overload decreases by this hysteresis value.	1

#### Notes:

- Not tested in production.
- Continuous operation above 145°C junction temperature may degrade device reliability.
- This parameter is tested at 1 kHz normal polarity with 40 mA loop current in production. Performance at other frequencies is guaranteed by characterization.
- This parameter is tested at 1 kHz normal polarity with open loop in production. Performance at other frequencies is guaranteed by characterization.
- This parameter is tested with DC in production. Performance at frequencies is guaranteed by characterization.
- Note, longitudinal balance seen at Tip/Ring will be determined by the resistance matching of the PTC and any other series elements.



## Data Friendly Transient Specifications

The Le79271 SLIC is one device of a chipset that will be used in integrated voice and data (IVD) applications. The basic requirement for devices used in IVD applications is not to create CRC errors during normal operating conditions. In IVD applications the Le79271 device will be used with a splitter and a data transformer circuit. The basic requirement of no CRC errors ultimately translates to a requirement on the maximum allowable transient at the output of the data transformer.

### IVD Specifications

Unless otherwise specified, test conditions are:  $V_{CC} = +3.3\text{ V}$ ,  $V_{BH} = -60\text{ V}$ ,  $V_{BL} = -36\text{ V}$ ,  $V_{BP} = +60\text{ V}$ . A simplified diagram of an IVD POTS Splitter and Data Transformer circuit is shown in Figure 2. The A/B (Tip/Ring) output of the splitter is terminated with  $600\ \Omega$  AC in the voiceband and  $100\ \Omega$  in the xDSL band. The specifications are for the peak transient voltage,  $V_{DATA}$ , generated across a  $100\ \Omega$  data termination resistor.

Table 5. IVD Specifications

#	Item	Condition	Min	Typ	Max	Unit
1	BATSW Transient	$V_{BH} = -140\text{V}$ ; $V_{BP} = 0\text{V}$ Switch BATSW from OFF to ON		$\pm 5$		mVpk
		$V_{BH} = -140\text{V}$ ; $V_{BP} = 0\text{V}$ Switch BATSW from ON to OFF		$\pm 5$		mVpk
2	VBPSW Transient	$V_{BH} = -40\text{V}$ ; $V_{BP} = +100\text{V}$ Switch VBPSW from OFF to ON		$\pm 5$		mVpk
		$V_{BH} = -40\text{V}$ ; $V_{BP} = +100\text{V}$ Switch VBPSW from ON to OFF		$\pm 5$		mVpk
3	Standby Mode Transient	Switch Mode from Active to Standby		$\pm 5$		mVpk
		Switch Mode from Standby to Active		$\pm 5$		mVpk

Figure 2. IVD POTS Splitter and Data Transformer

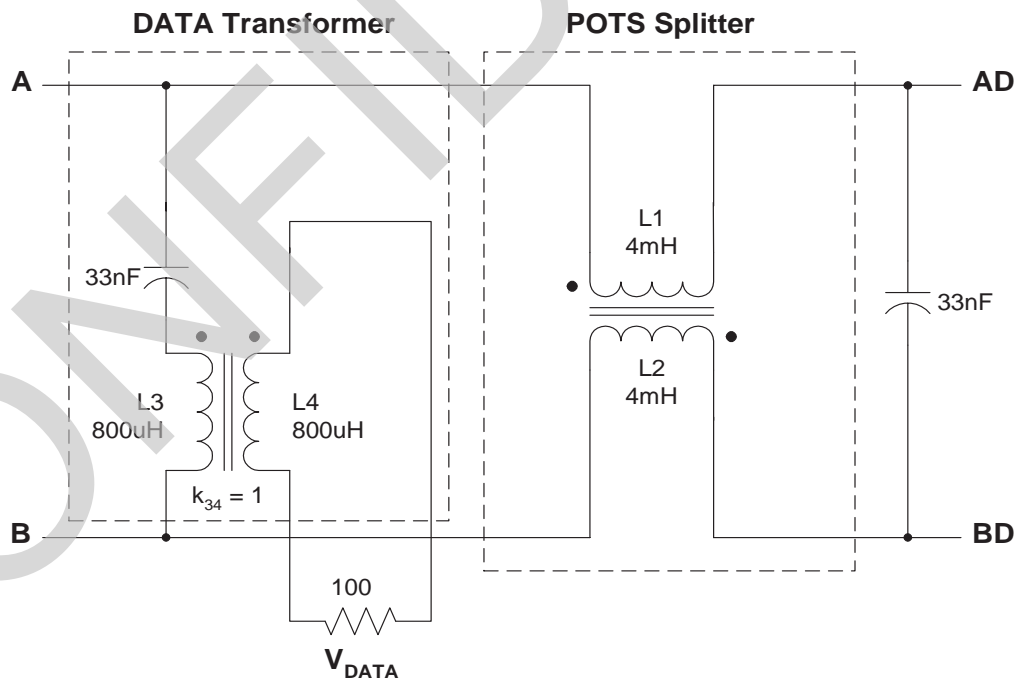

## OPERATING MODES

The Le79271 device receives multiplexed control data on the P0, P1 and P2 pins (the P-bus). The LD pin controls the loading of the P-bus data into the proper bits of the device control register as directed by the SEL pin. When SEL is "0", data on P0, P1 and P2 is loaded into one 3-bit register that controls the operating modes of the SLIC. When SEL is "1", data on P0, P1 and P2 is loaded into another 3-bit register that controls the operating condition of the switches in the SLIC. When LD is a "1", data on the P-bus is prohibited from entering the control register. When LD is a "0", data on the P-bus is directed by SEL to control the corresponding bits of the control register (transparent latch). The "0" to "1" transition of LD latches the data into the control register.

**Table 6. Operating Modes**

SEL	P2	P1	P0	Operating Mode
0	0	0	0	Disconnect
0	0	0	1	Tip Open
0	0	1	0	Ring Open
0	0	1	1	Standby
0	1	0	0	Disconnect
0	1	0	1	Tip Open Test
0	1	1	0	Ring Open Test
0	1	1	1	Active

**Table 7. Operating Conditions**

SEL	P2	P1	P0	Operating Condition		
				BATSW	VBPSW	TSTSW
1	0	0	0	OFF	OFF	OFF
1	0	0	1	ON	OFF	OFF
1	0	1	0	OFF	ON	OFF
1	0	1	1	ON	ON	OFF
1	1	0	0	OFF	OFF	ON
1	1	0	1	ON	OFF	ON
1	1	1	0	OFF	ON	ON
1	1	1	1	ON	ON	ON

*Note:*

*BATSW Off applies VBL.*

*BATSW On applies VBH.*

*VBPSW On applies VBP.*

*TSTSW On applies test load.*

## Operating Mode Descriptions

The operating condition of battery switches BATSW and VBPSW determine the battery voltage for all operating modes. The supply voltages are thus completely independent of the mode selected.

**Table 8. Operating Mode Descriptions**

Operating Mode	Description
Disconnect	<p>As much SLIC circuitry as possible is turned OFF (powered down).</p> <p>The AD and BD amplifiers are high impedance (<math>&gt; 2\text{ M}\Omega</math>) to any external voltage between VBP (VBPSW ON) or BGND (VBPSW OFF) and VBH (BATSW ON) or VBL (BATSW OFF). However, if the battery switches are OFF the amplifier outputs can be pulled to VBP and VBH, but the leakage current may increase up to the value of the respective supply current as specified for the disconnect mode.</p> <p>Pins AD and BD are forced to AGND by a high impedance current source.</p> <p>Output currents IA, IB and IMT are invalid.</p>
Active	<p>Normal operation.</p> <p>All SLIC circuits are active at full bias current for maximum performance.</p>
Standby	<p>Same as the Active Mode except bias currents are reduced as much as possible to conserve power.</p> <p>Performance is reduced for some SLIC parameters.</p> <p>The SLIC automatically returns to the Active Mode if the IAD current and/or IBD current exceeds <math>\pm 15\text{ mA}</math>. This is accomplished by resetting the SLIC control register; therefore, in order to return to the Standby Mode, the SLIC control register must be set again to the Standby Mode via the P-bus.</p>
Tip Open	<p>Uses Standby Mode biasing. The SLIC automatically returns to the Tip Open Test Mode if the current in BD exceeds <math>\pm 15\text{ mA}</math>.</p> <p>The AD drive amplifier is turned OFF (powered down).</p> <p>The AD amplifier is high impedance (<math>&gt; 2\text{ M}\Omega</math>) to any external voltage between VBP (VBPSW ON) or BGND (VBPSW OFF) and VBH (BATSW ON) or VBL (BATSW OFF). However, if the battery switches are OFF the amplifier output can be pulled to VBP and VBH, but the leakage current may increase up to the value of the respective supply current as specified for the Tip Open mode.</p> <p>Pin AD is forced to AGND by a high impedance current source.</p> <p>Output currents IA and IMT are invalid; output current IB is valid.</p>
Ring Open	<p>Uses Standby Mode biasing. The SLIC automatically returns to the Ring Open Test Mode if the current in AD exceeds <math>\pm 15\text{ mA}</math>.</p> <p>The BD drive amplifier is turned OFF (powered down).</p> <p>The BD amplifier is high impedance (<math>&gt; 2\text{ M}\Omega</math>) to any external voltage between VBP (VBPSW ON) or BGND (VBPSW OFF) and VBH (BATSW ON) or VBL (BATSW OFF). However, if the battery switches are OFF the amplifier output can be pulled to VBP and VBH, but the leakage current may increase up to the value of the respective supply current as specified for the Ring Open mode.</p> <p>Pin BD is forced to AGND by a high impedance current source.</p> <p>Output currents IB and IMT are invalid; output current IA is valid.</p>
Tip Open Test	Same as the Tip Open Mode except Active Mode biasing is used.
Ring Open Test	Same as the Ring Open Mode except Active Mode biasing is used.

## TIMING SPECIFICATIONS

Table 9. Timing Specifications

Symbol	Signal	Parameter	Min	Typ	Max	Unit
trSLD	LD	LD rise time			2	μs
tfSLD	LD	LD fall time			2	
tSLDPW	LD	Pulse width	3			
tSDXSU	P0, P1, P2, SEL	Data setup time	2			
tSDXHD	P0, P1, P2, SEL	Data hold time	2			
tSDXPW	P0, P1, P2, SEL	Pulse width	7			

## WAVEFORMS

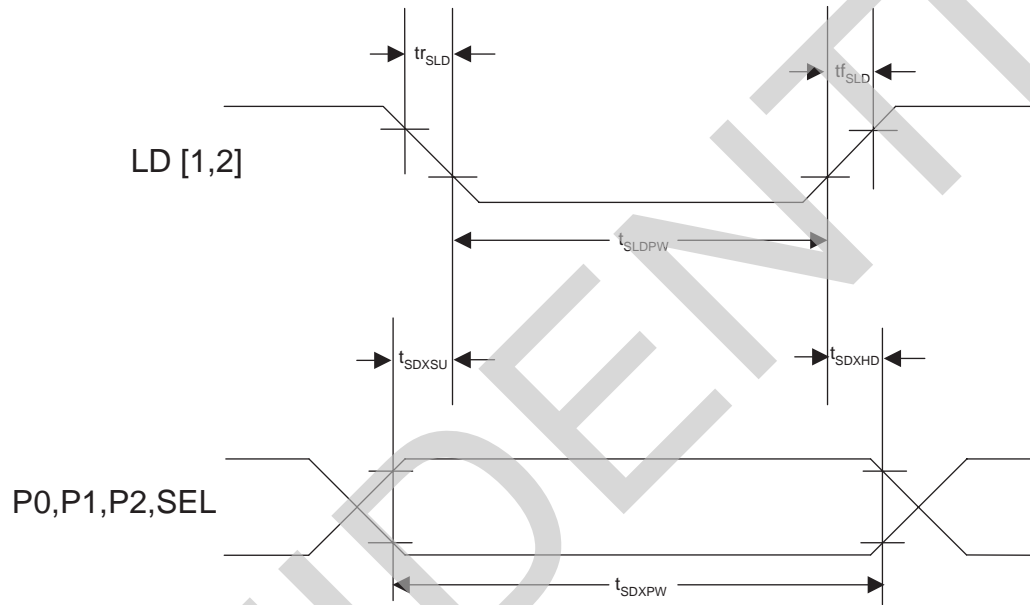

**PHYSICAL DIMENSIONS**

**28-Pin QFN**

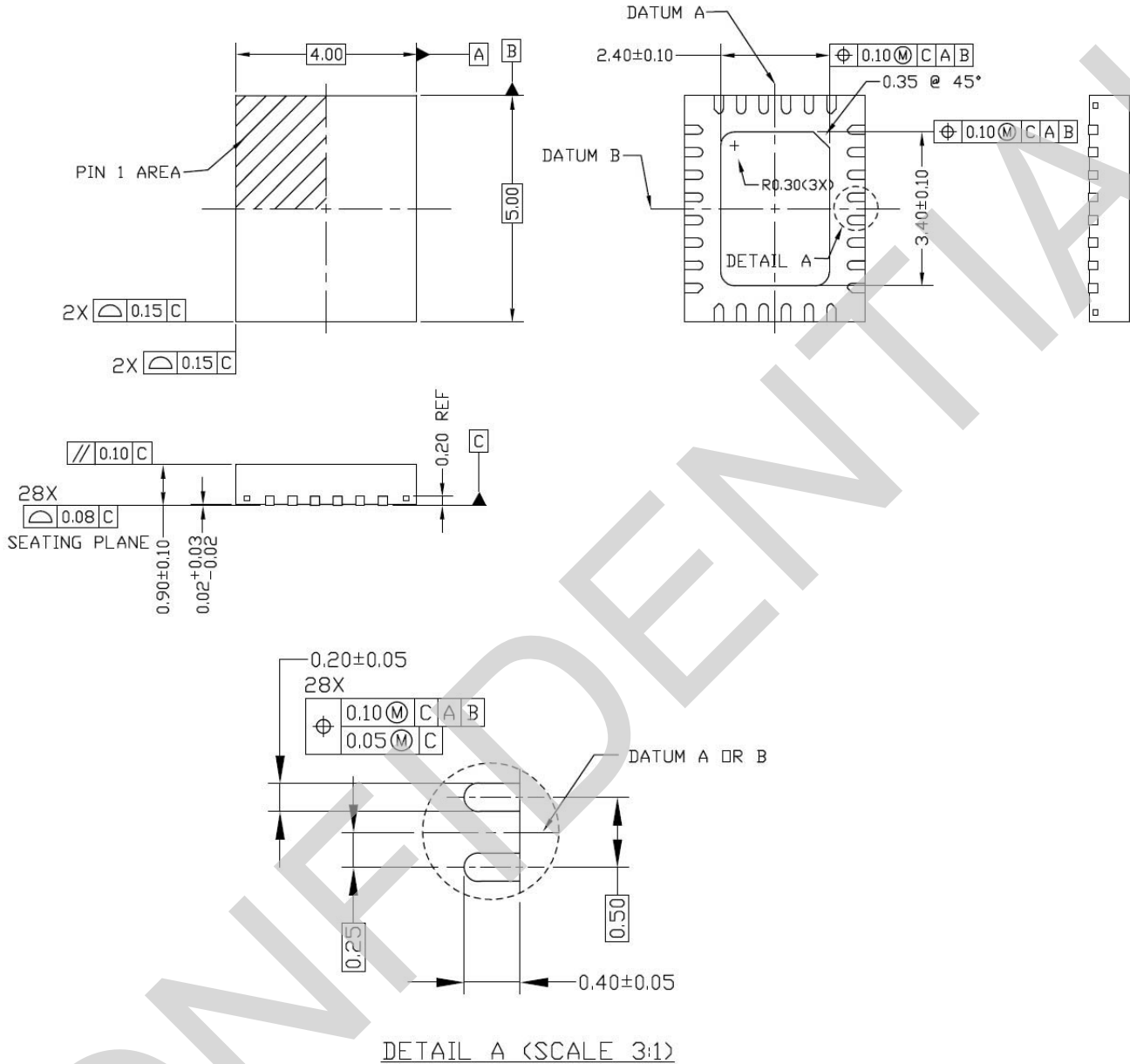

**NOTES:**

1. DIMENSIONING AND TOLERANCE IS IN CONFORMANCE TO ASME Y14.5-1994.  
ALL DIMENSIONS ARE IN MILLIMETERS \* IN DEGREES
2. DIMENSION OF LEAD WIDTH APPLIES TO METALLIZED TERMINAL AND IS MEASURED BETWEEN 0.15mm AND 0.30mm FROM THE TERMINAL TIP (BOTH ROWS). IF THE TERMINAL HAS OPTIONAL RADIUS ON THE END OF THE TERMINAL, THE LEAD WIDTH DIMENSION SHOULD NOT BE MEASURED IN THAT RADIUS AREA

**Note:**

Packages may have mold tooling markings on the surface. These markings have no impact on the form, fit or function of the device. Markings will vary with the mold tool used in manufacturing.

## REVISION HISTORY

### Version 8 to 9

- Page 14; Table 3, Items 20 and 21, Rejection Ratio typical values provided.
- Page 16; Table 4, Items 14 and 15, notes on Longitudinal Balance test procedure added.

### Version 9 to 10

- Page 11; Electrical Ranges, VBH minimum value lowered from -42.5 V to -40 V.
- Page 21; Physical Dimensions, new package drawing. Previous drawing had lead width misstated.
- Minor text edits.

### Version 10 to 11

- Added Le79271A device.
- Page 12; Table 2, added Operating Condition column.
- Page 16; Table 4, Item 14, added Le79271A longitudinal balance and added note 6.
- Minor text edits.

### Version 11 to 12

- Changed branding from Zarlink Semiconductor to Microsemi Corporation.
- Page 11; Electrical Operating Ranges description, changed reliability reference document from "section 4.6.2 of Bellcore TR-TSY-000357" to "Telcordia GR-357-CORE".
- Page 11, 12; Specifications, Table 1, Table 2, added Ringing descriptor after Boosted Battery.

### Version 12 to 13

- Page 11, Specifications, updated Power Dissipation section.
- Page 12, Supply Currents, Table 2, updated Supply Current Specifications.
- Minor text edits.



**For more information about all Microsemi CMPG products  
visit our Web Site at  
[www.microsemi.com](http://www.microsemi.com)**

Information relating to products and services furnished herein by Microsemi Corporation or its subsidiaries (collectively "Microsemi") is believed to be reliable. However, Microsemi assumes no liability for errors that may appear in this publication, or for liability otherwise arising from the application or use of any such information, product or service or for any infringement of patents or other intellectual property rights owned by third parties which may result from such application or use. Neither the supply of such information or purchase of product or service conveys any license, either express or implied, under patents or other intellectual property rights owned by Microsemi or licensed from third parties by Microsemi, whatsoever. Purchasers of products are also hereby notified that the use of product in certain ways or in combination with Microsemi, or non-Microsemi furnished goods or services may infringe patents or other intellectual property rights owned by Microsemi.

This publication is issued to provide information only and (unless agreed by Microsemi in writing) may not be used, applied or reproduced for any purpose nor form part of any order or contract nor to be regarded as a representation relating to the products or services concerned. The products, their specifications, services and other information appearing in this publication are subject to change by Microsemi without notice. No warranty or guarantee express or implied is made regarding the capability, performance or suitability of any product or service. Information concerning possible methods of use is provided as a guide only and does not constitute any guarantee that such methods of use will be satisfactory in a specific piece of equipment. It is the user's responsibility to fully determine the performance and suitability of any equipment using such information and to ensure that any publication or data used is up to date and has not been superseded. Manufacturing does not necessarily include testing of all functions or parameters. These products are not suitable for use in any medical products whose failure to perform may result in significant injury or death to the user. All products and materials are sold and services provided subject to Microsemi's conditions of sale which are available on request.

Microsemi, the Microsemi logo, Zarlink, and combinations thereof, Power Matters, SLAC, VeriVoice, VoiceEdge, VoicePort, and VoicePath are trademarks or registered trademarks of Microsemi Corporation. All other trademarks mentioned in this document are the property of their respective owners.

Copyright © 2012. All Rights Reserved

TECHNICAL DOCUMENTATION - NOT FOR RESALE

Microsemi documents marked "Preliminary" relate to products which are not yet released to production and are identified with an "ENG" suffix in their part number. Such products and their associated Preliminary Data Sheet specifications are supplied only for testing and on the express understanding that (i) such products have not been fully tested or characterized under intended modes of operation and may contain defects; (ii) Microsemi makes no representation or warranty regarding such products or Preliminary Data Sheets; and (iii) Microsemi disclaims any liability for claims, demands and damages, including and without limitation special, indirect and consequential damages resulting from any loss arising out of the application, use or performance of such products or specifications. Such products and Preliminary Data Sheets may be changed or discontinued by Microsemi at any time without notice.