

1.8V-3.3V PicoPLL™ Programmable Clock™

FEATURES

- Advanced One Time Programmable PLL design.
- Programmable PLL or Direct Oscillation operation.
- Very low Jitter (30-70ps Pk-Pk typical)
- Output Frequency range
 - $\leq 110\text{MHz}$ @ 1.8V operation
 - $\leq 166\text{MHz}$ @ 2.5V operation
 - $\leq 200\text{MHz}$ @ 3.3V operation
- Input Frequency: Fundamental crystal
 - 10MHz to 50MHz.
- 8bit Switch Capacitor for crystal CLoad tuning
 - 8pF to 12pF
- Low current consumption, $<10\mu\text{A}$ when PDB is activated.
- One programmable I/O pin can be configured as Output Enable (OE) input, Power Down (PDB) input, Frequency Select (FSEL) input or 2nd clock output.
- Single 1.8V, 2.5V, or 3.3V $\pm 10\%$ power supply
- Operating temperature range from -40°C to 85°C
- Available in 12 mil to 6 mil thickness

PAD CONFIGURATION

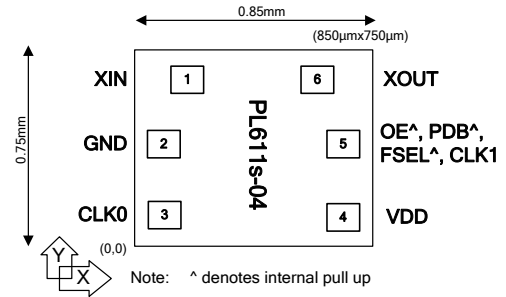

DIE SPECIFICATION

Parameter	Value
Chip size	0.75 x 0.85mm
Chip thickness	Optional (See Ordering Information)
PAD size	90 μm
Chip Base	GND level

DESCRIPTION

The PL611s-04 is a high performance low-cost general purpose frequency synthesizer and a member of PicoPLL™ Factory Programmable Clock. Designed to fit in a small 2.5mmx2.0mm oscillator module for high performance applications, the PL611s offers the best phase noise and jitter performance, smallest die size, and power consumption of any comparable device. The power down feature of PL611s, when activated, allows the IC to consume less than 10 μA of power, while its programming flexibility allows generating any output, using a low-cost crystal input.

BLOCK DIAGRAM

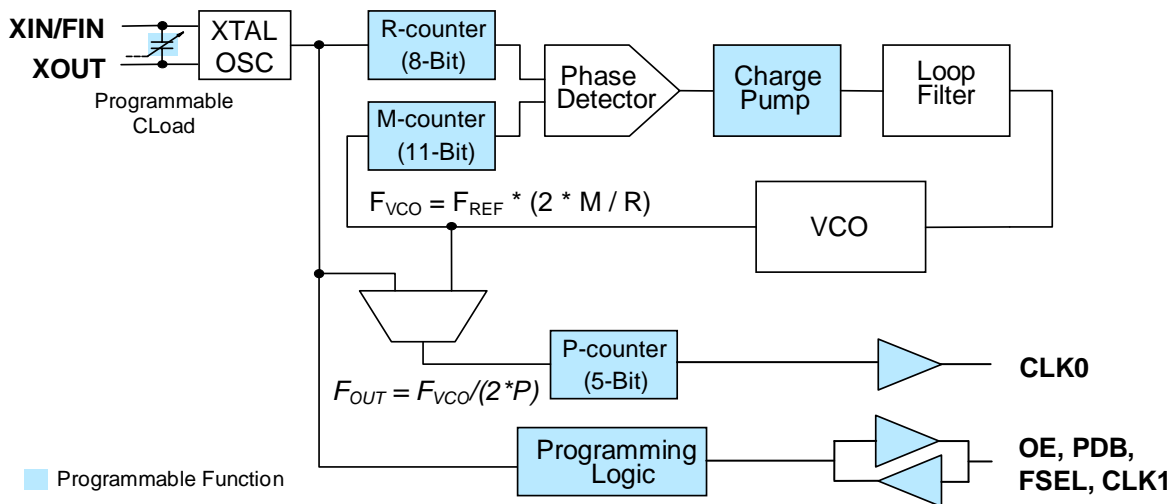

1.8V-3.3V PicoPLL™ Programmable Clock™
KEY PROGRAMMING PARAMETERS

Output Frequency	Output Drive Strength	Crystal Load	Programmable Input/Output	Charge-Pump Current
CLK0 PLL Mode : $CLK0 = F_{IN} * M / (R * P)$ Where: <ul style="list-style-type: none"> • M=11 bit • R= 8 bit • P= 5 bit P is an Odd/Even Divider Direct Oscillation Mode: $CLK0 = F_{IN}$ or $F_{IN} / (2 * P)$ CLK1 = F_{IN} , $F_{IN}/2$, CLK0 or CLK0/2	Three optional drives to choose from. They are: <ul style="list-style-type: none"> • Low: 4mA • Std: 8mA (default) • High: 16mA 	Programmable CLoad Tuning <ul style="list-style-type: none"> • 8pF to 12pF • ±50ppm typical 	One pad can be configured as: <ul style="list-style-type: none"> • OE – input • PDB – input • FSEL – input • CLK1 – output 	Charge pump current <ul style="list-style-type: none"> • 4 levels; programmable

PAD ASSIGNMENT AND DESCRIPTION (PL611s-04)

Name	Pad Assignment*			Type	Description												
	Pad #	X (µm)	Y (µm)														
XIN	1	125	665	I	Crystal Input pad												
GND	2	85	375	P	GND connection												
CLK0	3	85	115	O	Programmable Clock Output												
VDD	4	765	115	P	VDD connection												
OE, PDB, FSEL, CLK1	5	765	375	B	This programmable I/O pin can be configured as an Output Enable (OE) input, Power Down input (PDB), Frequency Select (FSEL) input or CLK1 clock output.												
					<table border="1"> <thead> <tr> <th>State</th> <th>OE</th> <th>PDB</th> <th>FSEL</th> </tr> </thead> <tbody> <tr> <td>0</td> <td>Tri-state CLK0</td> <td>Power Down Mode Tri-state CLK0</td> <td>Bank 0</td> </tr> <tr> <td>1 (default)</td> <td>Operating mode</td> <td>Operating mode</td> <td>Bank 1</td> </tr> </tbody> </table>	State	OE	PDB	FSEL	0	Tri-state CLK0	Power Down Mode Tri-state CLK0	Bank 0	1 (default)	Operating mode	Operating mode	Bank 1
					State	OE	PDB	FSEL									
0	Tri-state CLK0	Power Down Mode Tri-state CLK0	Bank 0														
1 (default)	Operating mode	Operating mode	Bank 1														
XOUT	6	725	665	O	Crystal Output pad												

* Note: The X/Y coordinates indicate pad centers.

1.8V-3.3V PicoPLL™ Programmable Clock™
ELECTRICAL SPECIFICATIONS
ABSOLUTE MAXIMUM RATINGS

PARAMETERS	SYMBOL	MIN.	MAX.	UNITS
Supply Voltage Range	V_{DD}	-0.5	7	V
Input Voltage Range	V_I	-0.5	$V_{DD}+0.5$	V
Output Voltage Range	V_O	-0.5	$V_{DD}+0.5$	V
Data Retention @ 85°C		10		Year
Storage Temperature	T_S	-65	150	°C
Ambient Operating Temperature		-40	85	°C

Exposure of the device under conditions beyond the limits specified by Maximum Ratings for extended periods may cause permanent damage to the device and affect product reliability. These conditions represent a stress rating only, and functional operations of the device at these or any other conditions above the operational limits noted in this specification is not implied.

AC SPECIFICATIONS

PARAMETERS	CONDITIONS	MIN.	TYP.	MAX.	UNITS
Crystal Input Frequency (XIN)	Fundamental Crystal	10		50	MHz
Output Frequency	@ $V_{DD} = 3.3V$			200	MHz
	@ $V_{DD} = 2.5V$			166	
	@ $V_{DD} = 1.8V$			110	
Settling Time	At power-up (after $V_{DD} \geq 1.62V$)			2	ms
Output Enable Time (See MTC-1)	OE Function; $T_a=25^\circ C$, 15pF Load. Add one clock period to this measurement for a usable clock output.			10	ns
	PDB Function; $T_a=25^\circ C$, 15pF Load			2	ms
Output Disable Time (See MTC-1)	$T_a=25^\circ C$, 15pF Load			100	ns
VDD Sensitivity	Frequency vs. $V_{DD} \pm 10\%$	-2		2	ppm
Output Rise Time (See MTC-1)	15pF Load, 10/90% V_{DD} , High Drive, 3.3V		1	1.5	ns
Output Fall Time (See MTC-1)	15pF Load, 90/10% V_{DD} , High Drive, 3.3V		1	1.5	ns
Duty Cycle (See MTC-1)	@2.5V and 3.3V over entire frequency range, $V_{DD}/2$	45	50	55	%
	@1.8V, $\leq 75MHz F_{OUT}$, $V_{DD}/2$	45	50	55	
	@1.8V, $75MHz < F_{OUT} \leq 110MHz$	40		60	
Period Jitter, Pk-to-Pk* (10,000 samples measured) (See MTC-3)	With capacitive decoupling between V_{DD} and GND.		70		ps

* Note: Jitter performance depends on the programming parameters.

1.8V-3.3V PicoPLL™ Programmable Clock™
DC SPECIFICATIONS

PARAMETERS	SYMBOL	CONDITIONS	MIN.	TYP.	MAX.	UNITS
Supply Current, Dynamic, Loaded Output	I_{DD}	@ $V_{DD} = 3.3V$, 30MHz, load=15pF		6.0		mA
Supply Current, Dynamic, Loaded Output	I_{DD}	@ $V_{DD} = 2.5V$, 30MHz, load=15pF		3.9		mA
Supply Current, Dynamic, Loaded Output	I_{DD}	@ $V_{DD} = 1.8V$, 30MHz, load=5pF		2.1		mA
PLL Off: Supply Current, Dynamic, Loaded Output	I_{DD}	@ $V_{DD} = 3.3V$, 30MHz, load=15pF		2.0		mA
PLL Off: Supply Current, Dynamic, Loaded Output	I_{DD}	@ $V_{DD} = 2.5V$, 30MHz, load=15pF		1.6		mA
PLL Off: Supply Current, Dynamic, Loaded Output	I_{DD}	@ $V_{DD} = 1.8V$, 30MHz, load=5pF		0.8		mA
Stand By Current, Loaded Outputs (See MTC-1)	I_{DD}	When PDB=0			<10	μA
Operating Voltage	V_{DD}		1.62		3.63	V
Output Low Voltage	V_{OL}	$I_{OL} = +4mA$ Standard Drive			0.4	V
Output High Voltage	V_{OH}	$I_{OH} = -4mA$ Standard Drive	$V_{DD} - 0.4$			V
Output Current, Low Drive (See MCT-2)	I_{OSD}	$V_{OL} = 0.4V$, $V_{OH} = 2.4V$, 3.3V Operation	4			mA
Output Current, Standard Drive (See MCT-2)	I_{OSD}	$V_{OL} = 0.4V$, $V_{OH} = 2.4V$, 3.3V Operation	8			mA
Output Current, High Drive (See MCT-2)	I_{OHD}	$V_{OL} = 0.4V$, $V_{OH} = 2.4V$, 3.3V Operation	16			mA

CRYSTAL SPECIFICATIONS

PARAMETERS	SYMBOL	MIN.	TYP.	MAX.	UNITS
Fundamental Crystal Resonator Frequency	F_{XIN}	10		50	MHz
Crystal Loading Rating (The IC can be programmed for any value in this range.)	$C_{L(xtal)}$	8		12	pF
Maximum Sustainable Drive Level				100	μW
Operating Drive Level			30		μW
Crystal Shunt Capacitance	C_0			4	pF
Effective Series Resistance, Fundamental, 10 - 50MHz (See MCT-4)	ESR			30	Ω

MEASUREMENT TEST CIRCUITS (MTC)

MTC-1: Rise Time, Fall Time, Duty Cycle, VOL, VOH, I_{dd}, Power Down Current, Output Enable/Disable

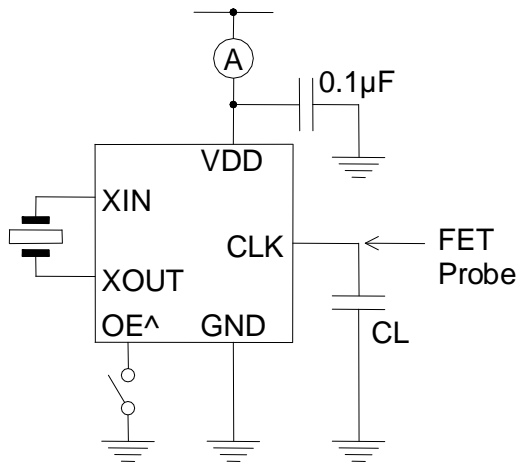

MTC-3: Jitter and Phase Noise

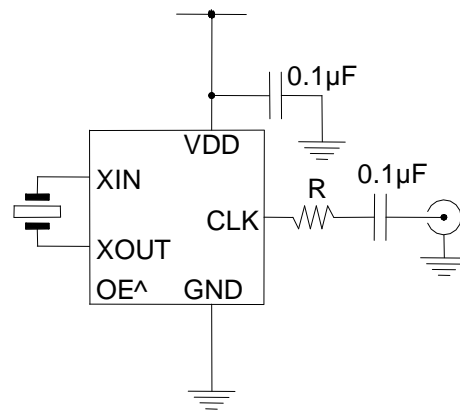

MTC-2: Output Drive Current and Output Impedance

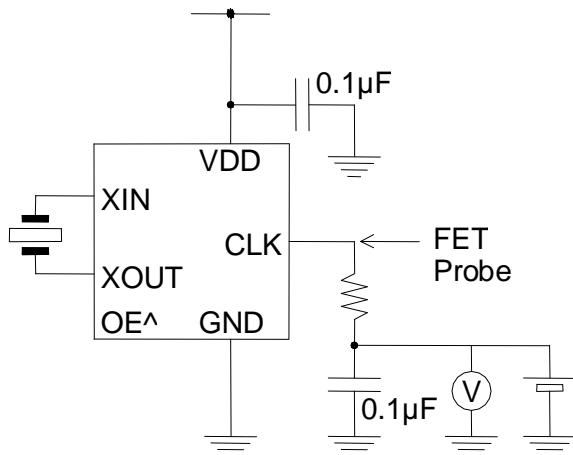

MTC-4: Negative Resistance

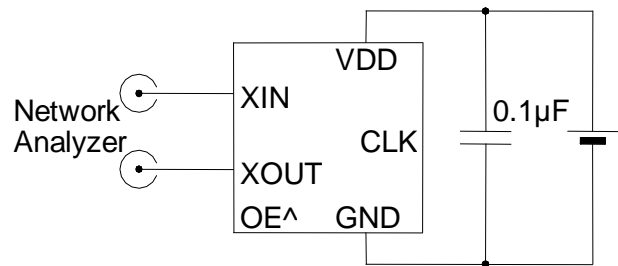

1.8V-3.3V PicoPLL™ Programmable Clock™

WAVEFORM SWITCHING CHARACTERISTICS

Rise and Fall times:

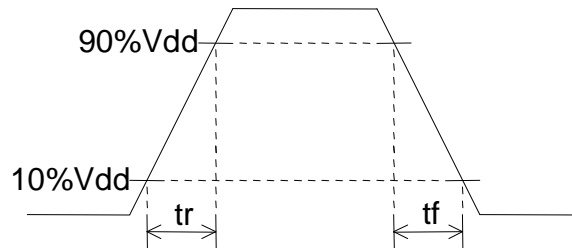

Duty Cycle:

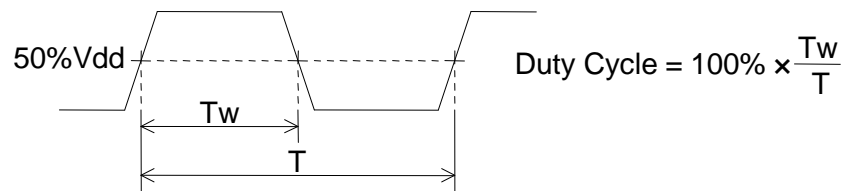

VOH, VOL:

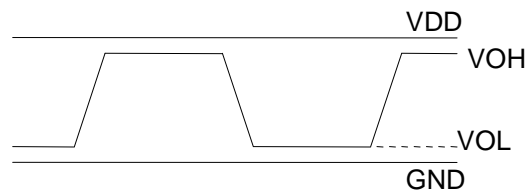

1.8V-3.3V PicoPLL™ Programmable Clock™

ORDERING INFORMATION

For part ordering, please contact our Sales Department:

2180 Fortune Drive, San Jose, CA 95131, USA

Tel: (408) 944-0800 Fax: (408) 474-1000

PART NUMBER

The order number for this device is a combination of the following:
Part number, Package type and Operating temperature range

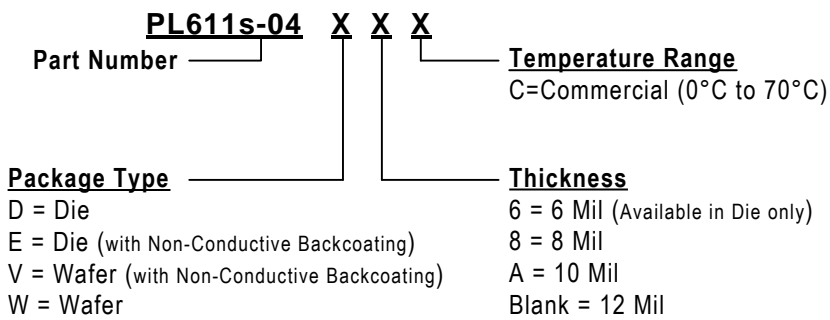

Part / Order Number	Package Option	Temperature
PL611s-04DxC	Die (Waffle Pack)	0°C to +70°C
PL611s-04ExC	Die (Waffle Pack)	0°C to +70°C
PL611s-04VxC	Wafer	0°C to +70°C
PL611s-04WxC	Wafer	0°C to +70°C

Micrel Inc., reserves the right to make changes in its products or specifications, or both at any time without notice. The information furnished by Micrel is believed to be accurate and reliable. However, Micrel makes no guarantee or warranty concerning the accuracy of said information and shall not be responsible for any loss or damage of whatever nature resulting from the use of, or reliance upon this product.

LIFE SUPPORT POLICY: Micrel's products are not authorized for use as critical components in life support devices or systems without the express written approval of the President of Micrel Inc.