

1.8V-3.3V PicoPLL, 3-PLL, 200MHz, 3 Output Clock IC

FEATURES

- Designed for PCB space savings with 3 low-power Programmable PLLs and 3 distinct clock outputs.
- Low-power consumption (<10µA when PDB is activated)
- Output frequency:
 - ≤110MHz @ 1.8V operation
 - ≤166MHz @ 2.5V operation
 - ≤200MHz @ 3.3V operation
- Input frequency:
 - Fundamental Crystal: 10MHz to 40MHz
 - Reference Input: 10MHz to 200MHz
- Programmable I/O pins can be configured as Output Enable (OE), Power Down (PDB) inputs, or Clock output.
- Disabled outputs programmable as HiZ or Active Low
- Single 1.8V to 3.3V, ±10% power supply
- Operating temperature range from -40°C to 85°C
- Available in GREEN/RoHS compliant SOP-8L package.

DESCRIPTION

The PL613-05 is an advanced triple PLL design based on PicoPLL, world's smallest programmable clock, technology. This flexible programmable architecture is ideal for high performance, low-power, low-cost applications. When using the power down (PDB) feature the PL613-05 consumes less than 10 µA of power. Besides its small form factor and 3 distinct outputs that can reduce overall system costs, the PL613-05 offers superior phase noise, jitter and power consumption performance.

PIN CONFIGURATION

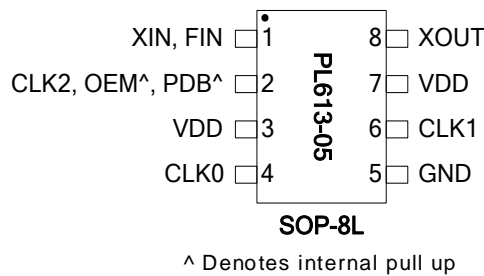

BLOCK DIAGRAM

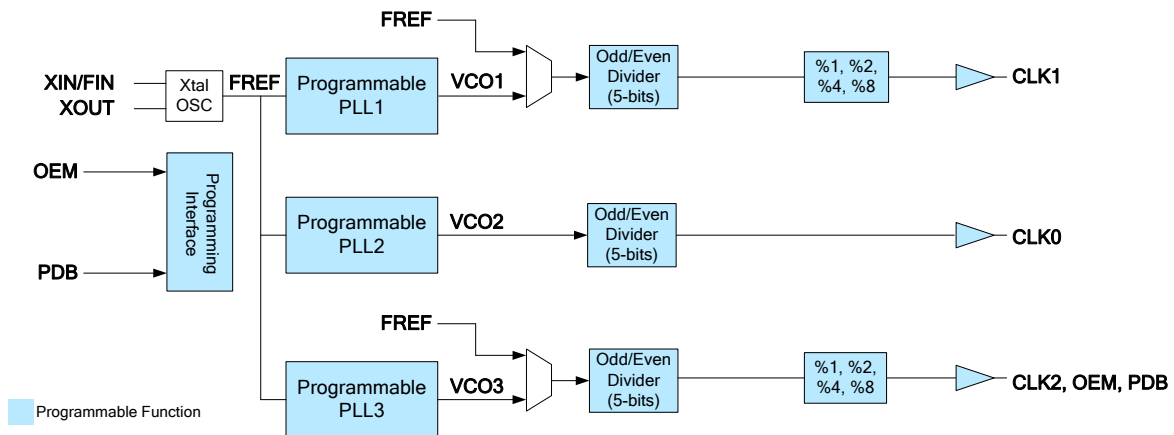

1.8V-3.3V PicoPLL, 3-PLL, 200MHz, 3 Output Clock IC
PACKAGE PIN ASSIGNMENT

Name	Package Pin #	Type	Description
XIN, FIN	1	I	Crystal or Reference Clock input
CLK2, OEM, PDB	2	B*	- Programmable Clock (CLK2) output, or - Output Enable Master (OEM) for all clock outputs, or - Power Down mode (PDB) input
VDD	3, 7	P	VDD connection
CLK0	4	B*	Programmable Clock (CLK0) output
GND	5	P	GND connection
CLK1	6	O	Programmable Clock (CLK1) output
XOUT	8	O	Crystal output pin. Do Not Connect when using FIN

* **Note:** All bidirectional buffers (I/Os) incorporate an internal 60K Ω pull up resistor except when PDB mode is used. In configurations that use PDB, the PDB pin will have a 10M Ω pull up resistor.

KEY PROGRAMMING PARAMETERS

CLK[0:2] Output Frequency	Output Drive Strength	Programmable Input/Output
CLK[0] F_{VCO2} / P CLK[1,2] $F_{VCOx} / (P*(1,2,4,8))$ or $F_{REF} / (P*(1,2,4,8))$ Where $F_{VCO} = F_{REF} * M / R$ M = 11 bit R = 8 bit P = 5 bit (Odd/Even Divider)	Each output has three optional drive strengths to choose from. They are: <ul style="list-style-type: none"> • Low: 4mA • Std: 8mA (default) • High: 16mA 	Most pins are multi-function I/Os and can be configured as: <ul style="list-style-type: none"> • OEM – (Master OE controlling all outputs) • PDB – (Power Down) • CLK[0:2] – (Output) • HiZ or Active Low disabled state

1.8V-3.3V PicoPLL, 3-PLL, 200MHz, 3 Output Clock IC

FUNCTIONAL DESCRIPTION

The PL613-05 is a highly featured, very flexible, advanced triple PLL design for high performance, low-power applications. The device accepts a low-cost fundamental crystal input of 10MHz to 40MHz or a reference clock input of 10MHz to 200MHz and is capable of producing 3 distinct output frequencies up to 200MHz. All 3-PLLs are fully programmable, with a total of four, 5-bit Post VCO, Odd/Even (patent pending) 'P-counter' dividers with additional 1, 2, 4 or 8 'Post P-counter' dividers to allow generating the most demanding frequencies easily. The outputs can be programmed to deliver the generated frequencies from the PLLs, or the reference input. Each bidirectional feature pin (I/O) on the PL613-05 incorporates a 60KΩ pull up resistor (10MΩ for PDB function) and can be configured to perform various functions. Usage of various design features of these products is mentioned in the following paragraphs.

PLL Programming

The three PLLs in PL613-05 are fully programmable. Each PLL is equipped with an 8-bit input frequency divider (R-Counter) and an 11-bit VCO frequency feedback loop (M-Counter) divider. The three PLL outputs are transferred to four 5-bit post VCO, Odd/Even (patent pending) dividers (P-Counter), as shown in the above diagrams. In addition, there are three optional (÷1, ÷2, ÷4 or ÷8) post P-Counter dividers, that can further divide the VCO frequencies. In general, the PLL output frequency is determined by the following formula

$$F_{OUT} = (F_{REF} * M) / (R * P)$$

For output calculations, please note that 'P' includes the 'P' counter bits plus the additional optional (÷1, ÷2, ÷4 or ÷8) dividers, if used.

CLKx (Clock Outputs)

There are 3 distinct output frequencies available on the PL613-05. Clock output frequencies can be configured as follows:

CLK[0]

$$F_{VCO2} / P$$

CLK[1,2]

$$F_{VCOx} / (P * (1,2,4,8)) \text{ or } F_{REF} / (P * (1,2,4,8))$$

Each output can be programmed with a 4mA, 8mA, or 16mA drive strength. The maximum output frequency is 200MHz @ 3.3V, 166MHz @ 2.5V or 110MHz @ 1.8V.

OEM (Master Output Enable)

One pin can be configured to be a single Master OE (OEM) input pin that controls all the outputs of the PL613-05. In addition the state of the disabled outputs can be programmed to float (Hi Z) or Active '0'. The OEM pin incorporates a 60kΩ pull up resistor for normal operating condition. The logic for OEM is shown below:

OEM Pin	OE Type (Programmable)	Osc	PLL	Output
0	0 (Default)	On	On	Hi Z
	1	On	On	Active '0'
1	Normal Operation (Default)			

Note: Typical enable time is 10ns.

Power-Down Control (PDB)

When activated, PDB 'Disables all the PLLs, the oscillator circuitry, counters, and all other active circuitry. PDB activation disables all outputs and the IC consumes <10μA of power. The PDB input incorporates a 10MΩ pull up resistor for normal operating condition.

The PDB feature can be programmed to allow the output to float (Hi Z), or to operate in the 'Active low' mode. The logic for PDB is shown below:

PDB Pin	PDB Type Program	Osc	PLL	Output
0	0 (Default)	Off	Off	Hi Z
	1	Off	Off	Active '0'
1	Normal Operation (Default)			

Note: Typical enable time is <2ms.

1.8V-3.3V PicoPLL, 3-PLL, 200MHz, 3 Output Clock IC

LAYOUT RECOMMENDATIONS

The following guidelines are to assist you with a performance optimized PCB design:

Signal Integrity and Termination Considerations

- Keep traces short!
- Trace = Inductor. With a capacitive load this equals ringing!
- Long trace = Transmission Line. Without proper termination this will cause reflections (looks like ringing).
- Design long traces (<1 inch) as “striplines” or “microstrips” with defined impedance.
- Match trace at one side to avoid reflections bouncing back and forth.

Decoupling and Power Supply Considerations

- Place decoupling capacitors as close as possible to the V_{DD} pin(s) to limit noise from the power supply
- Multiple V_{DD} pins should be decoupled separately for best performance.
- Addition of a ferrite bead in series with V_{DD} can help prevent noise from other board sources
- Value of decoupling capacitor is frequency dependant. Typical values to use are $0.1\mu F$ for designs using frequencies < 50MHz and $0.01\mu F$ for designs using frequencies > 50MHz.

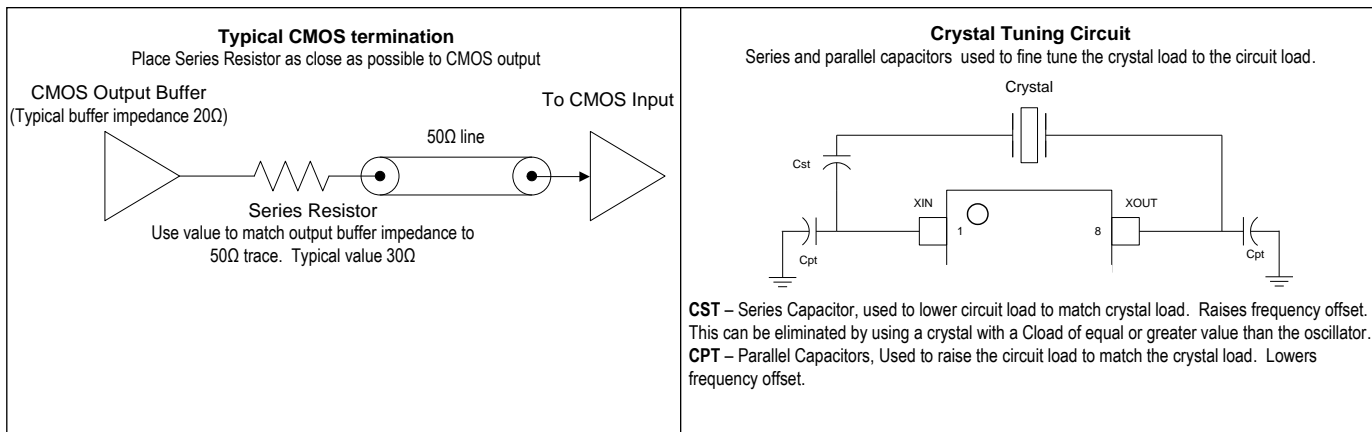

1.8V-3.3V PicoPLL, 3-PLL, 200MHz, 3 Output Clock IC
ELECTRICAL SPECIFICATIONS
ABSOLUTE MAXIMUM RATINGS

PARAMETERS	SYMBOL	MIN.	MAX.	UNITS
Supply Voltage Range	V_{DD}	-0.5	4.6	V
Input Voltage Range	V_I	-0.5	$V_{DD}+0.5$	V
Output Voltage Range	V_O	-0.5	$V_{DD}+0.5$	V
Soldering Temperature (Green package)			260	°C
Data Retention @ 85°C		10		Year
Storage Temperature	T_S	-65	150	°C
Ambient Operating Temperature*		-40	85	°C

Exposure of the device under conditions beyond the limits specified by Maximum Ratings for extended periods may cause permanent damage to the device and affect product reliability. These conditions represent a stress rating only, and functional operations of the device at these or any other conditions above the operational limits noted in this specification is not implied. *Operating temperature is guaranteed by design. Parts are tested to commercial grade only.

AC SPECIFICATIONS

PARAMETERS	CONDITIONS	MIN.	TYP.	MAX.	UNITS
Crystal Input Frequency (XIN)	Fundamental Crystal	10		40	MHz
Input (FIN) Frequency	@ $V_{DD} = 3.3V$	10		200	MHz
	@ $V_{DD} = 2.5V$			166	
	@ $V_{DD} = 1.8V$			110	
Input (FIN) Signal Amplitude	Internally AC coupled (High Frequency)	0.9		V_{DD}	V _{pp}
Input (FIN) Signal Amplitude	Internally AC coupled (Low Frequency) 3.3V ≤ 50MHz, 2.5V ≤ 40MHz, 1.8V ≤ 15MHz	0.1		V_{DD}	V _{pp}
Output Frequency	@ $V_{DD} = 3.3V$			200	MHz
	@ $V_{DD} = 2.5V$			166	
	@ $V_{DD} = 1.8V$			110	
Settling Time	At power-up (after V_{DD} increases over 1.62V)			2	ms
Output Enable Time	OE Function; $T_a = 25^\circ C$, 15pF Load			10	ns
	PDB Function; $T_a = 25^\circ C$, 15pF Load			2	ms
VDD Sensitivity	Frequency vs. $V_{DD} \pm 10\%$	-2		2	ppm
Output Rise Time	15pF Load, 10/90% V_{DD} , High Drive, 3.3V		1.2	1.7	ns
Output Fall Time	15pF Load, 90/10% V_{DD} , High Drive, 3.3V		1.2	1.7	ns
Duty Cycle	PLL Enabled, @ $V_{DD} / 2$, High Drive	45	50	55	%
Period Jitter, Pk-to-Pk* (10,000 samples)	Configuration Dependant, with capacitive decoupling between V_{DD} and GND.		300		ps

* Note: Jitter performance depends on the programming parameters.

1.8V-3.3V PicoPLL, 3-PLL, 200MHz, 3 Output Clock IC
DC SPECIFICATIONS

PARAMETERS	SYMBOL	CONDITIONS	MIN.	TYP.	MAX.	UNITS
Supply Current, Dynamic, Loaded CMOS Outputs	I_{DD}	All outputs @ 20MHz 10pF Load		15	21	mA
Supply Current, Dynamic, Loaded CMOS Outputs	I_{DD}	All outputs @ 20MHz 10pF Load		11	16	mA
Supply Current, Dynamic, Loaded CMOS Outputs	I_{DD}	All outputs @ 20MHz 10pF Load		8.5	11	mA
Supply Current	I_{DD}	When PDB=0 All outputs @ 20MHz 10pF Load, $V_{DD} = 3.3V$			<10	μA
Operating Voltage	V_{DD}	3.3V Operation	2.97	3.3	3.63	V
		2.5V Operation	2.25	2.5	2.75	
		1.8V Operation	1.62	1.8	1.98	
Output Low Voltage	V_{OL}	$I_{OL} = +4mA$ Std Drive			0.4	V
Output High Voltage	V_{OH}	$I_{OH} = -4mA$ Std Drive	$V_{DD} - 0.4$			V
Output Current, Low Drive	I_{OSD}	$V_{OL} = 0.4V, V_{OH} = 2.4V$	4			mA
Output Current, Std Drive	I_{OSD}	$V_{OL} = 0.4V, V_{OH} = 2.4V$	8			mA
Output Current, High Drive	I_{OHD}	$V_{OL} = 0.4V, V_{OH} = 2.4V$	16			mA

CRYSTAL SPECIFICATIONS

PARAMETERS		SYMBOL	MIN	TYP	MAX	UNITS
Fundamental Crystal Resonator Frequency		F_{XIN}	10		40	MHz
Crystal Loading Rating		$C_{L(xtal)}$		15		pF
Operating Drive Level				0.1	2	mW
Metal Can Crystal	Shunt Capacitance	C_0			5.5	pF
	ESR Max	ESR			40	Ω
Small SMD Crystal	Shunt Capacitance	C_0			2.5	pF
	ESR Max	ESR			60	Ω

1.8V-3.3V PicoPLL, 3-PLL, 200MHz, 3 Output Clock IC

PACKAGE DRAWINGS (GREEN PACKAGE COMPLIANT)

SOP-8L

Symbol	Dimension in MM	
	Min.	Max.
A	1.35	1.75
A1	0.10	0.25
A2	1.25	1.50
b	0.33	0.53
C	0.19	0.27
D	4.80	5.00
E	3.80	4.00
H	5.80	6.20
L	0.40	0.89
e	1.27 BSC	

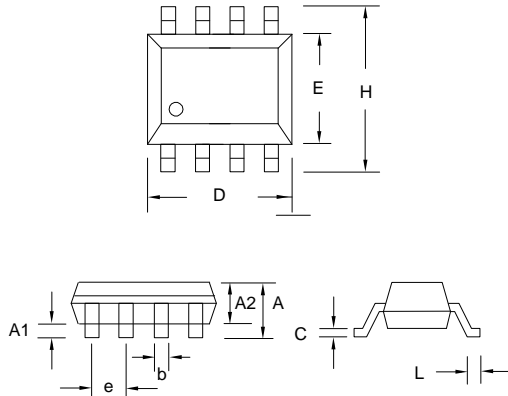

1.8V-3.3V PicoPLL, 3-PLL, 200MHz, 3 Output Clock IC

ORDERING INFORMATION (GREEN PACKAGE COMPLIANT)

For part ordering, please contact our Sales Department:

2180 Fortune Drive, San Jose, CA 95131, USA

Tel: (408) 944-0800 Fax: (408) 474-1000

PART NUMBER

The order number for this device is a combination of the following:
Part number, Package type and Operating temperature range

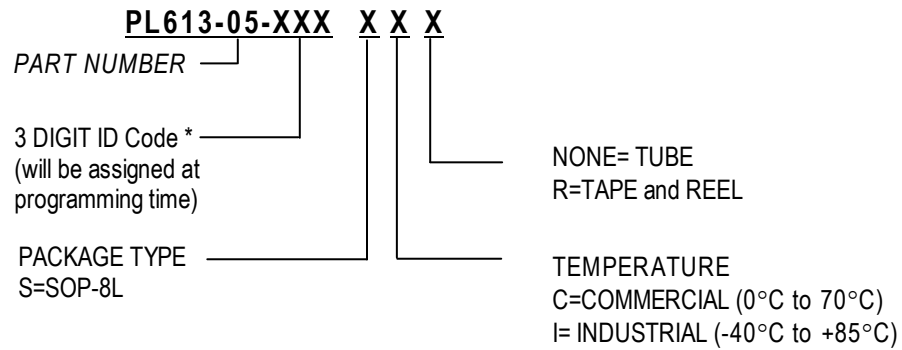

* Micrel will assign a unique 3-digit ID code for each approved programmed part number.

Part Number/Order Number	Marking†	Package Option
PL613-05-XXXSC PL613-05-XXXSI	P613-05 XXX LLLLL ⁽¹⁾	8-Pin SOP (Tube)
PL613-05-XXXSC-R PL613-05-XXXSI-R	P613-05 XXX LLLLL ⁽¹⁾	8-Pin SOP (Tape and Reel)

† **Marking Notes :**

1) LLLLL represents the production lot number

Micrel Inc., reserves the right to make changes in its products or specifications, or both at any time without notice. The information furnished by Micrel is believed to be accurate and reliable. However, Micrel makes no guarantee or warranty concerning the accuracy of said information and shall not be responsible for any loss or damage of whatever nature resulting from the use of, or reliance upon this product.

LIFE SUPPORT POLICY: Micrel's products are not authorized for use as critical components in life support devices or systems without the express written approval of the President of Micrel Inc.