

Two output ultra-low additive phase noise PCIe Gen 1 to 5, and UPI/QPI fanout buffer

Features

- One differential input which accepts any differential format.
- Two differential HCSL outputs
- Ultra-low additive jitter: 32fs (in 12kHz to 20MHz integration band at 400MHz clock frequency)
- Supports clock frequencies from 0 to 400MHz
- Supports 2.5V or 3.3V power supplies for HCSL outputs
- Embedded Low Drop Out (LDO) Voltage regulator provides superior Power Supply Noise Rejection
- Maximum output to output skew of 50ps
- Individual Output Enable pin for each differential pair
- Transfers Spread-Spectrum without attenuation

Ordering Information

| | | |
|-------------|------------|---------------|
| ZL40262LDG1 | 20 pin QFN | Trays |
| ZL40262LDF1 | 20 pin QFN | Tape and Reel |

Package size: 4 x 4 mm
-40°C to +85°C

Applications

- PCI Express generation 1/2/3/4/5 clock distribution
- UPI/QPI clock distribution
- Low jitter clock trees
- Logic translation
- Clock and data signal restoration
- High performance microprocessor clock distribution
- Test Equipment

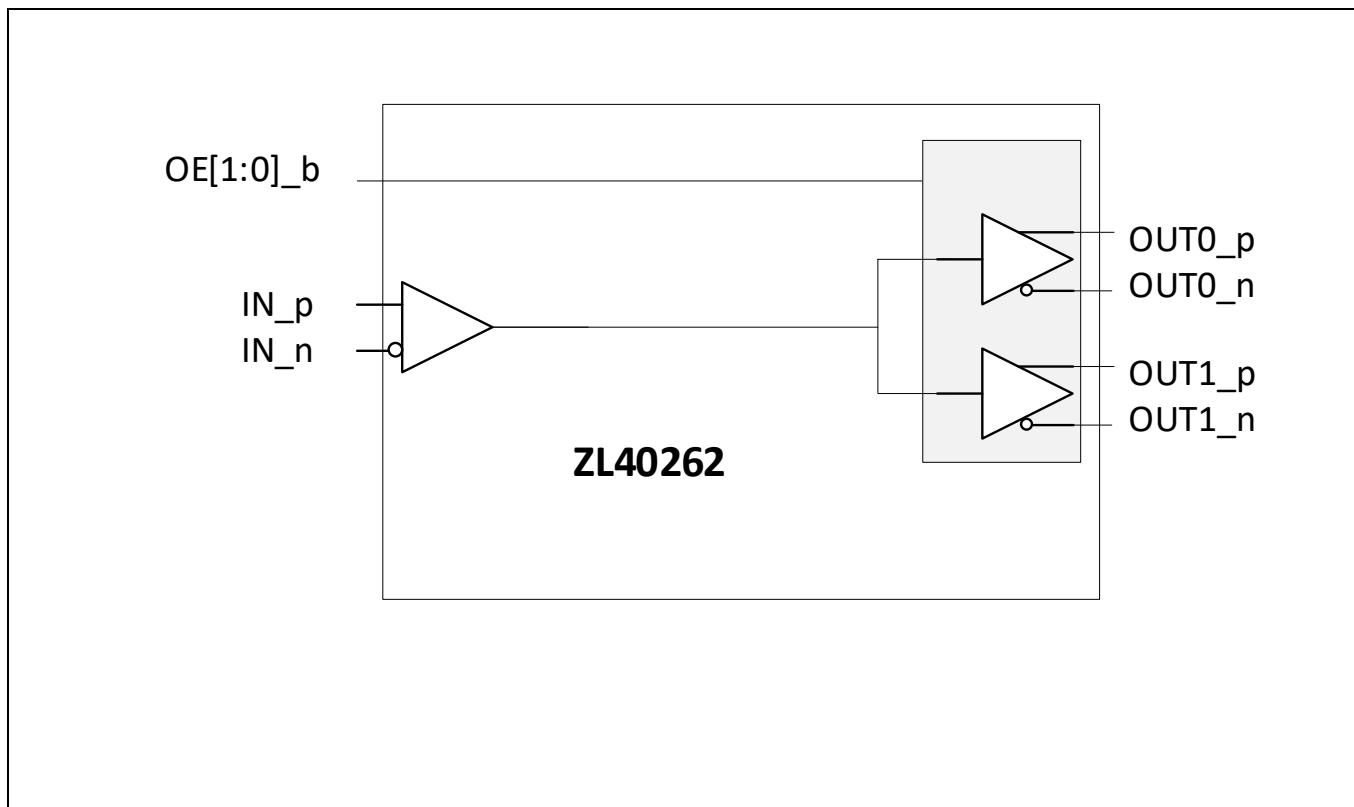

Figure 1. Functional Block Diagram

Table of Contents

| | |
|--|----|
| Features..... | 1 |
| Applications..... | 1 |
| Table of Contents | 2 |
| Pin Diagram | 5 |
| Pin Descriptions..... | 6 |
| Functional Description | 7 |
| Clock Inputs | 7 |
| Clock Outputs | 10 |
| Termination of unused outputs | 11 |
| Power Consumption | 11 |
| Power Supply Filtering..... | 11 |
| Power Supplies and Power-up Sequence..... | 12 |
| Device Control | 12 |
| Typical phase noise performance..... | 13 |
| AC and DC Electrical Characteristics | 14 |
| Absolute Maximum Ratings | 14 |
| Recommended Operating Conditions | 14 |
| Package Outline | 24 |
| Change history:..... | 25 |

List of Figures

| | | |
|------------|--|----|
| Figure 1. | Functional Block Diagram..... | 1 |
| Figure 2. | Pin Diagram | 5 |
| Figure 3. | Input driven by source terminated HCSL..... | 8 |
| Figure 4. | Input driven by receiver terminated HCSL | 8 |
| Figure 5. | Input driven by AC coupled LVPECL output..... | 8 |
| Figure 6. | Input driven by AC coupled LVDS..... | 9 |
| Figure 7. | Input driven by a single ended output | 9 |
| Figure 8. | Source terminated HCSL | 10 |
| Figure 9. | Receiver terminated HCSL..... | 10 |
| Figure 10. | Power Supply Filtering | 12 |
| Figure 11. | 100MHz HCSL Phase Noise | 13 |
| Figure 12. | 133MHz HCSL Phase Noise | 13 |
| Figure 13. | 400MHz HCSL Phase Noise | 13 |
| Figure 14. | Single-Ended Measurement Points for Absolute Cross Point and Swing | 21 |
| Figure 15. | Single-Ended Measurement Points for Delta Cross Point | 21 |
| Figure 16. | Single-Ended Measurement Points for Rise and Fall Time Matching | 21 |
| Figure 17. | Differential Measurement Points for Rise and Fall Time | 22 |
| Figure 18. | Differential Measurement Points for Ringback | 22 |
| Figure 19. | Test Circuit..... | 22 |

List of Tables

| | |
|--|----|
| <i>Table 1 Pin Descriptions</i> | 6 |
| <i>Table 2 Absolute Maximum Ratings*</i> | 14 |
| <i>Table 3 Recommended Operating Conditions*</i> | 14 |
| <i>Table 4 Current consumption</i> | 15 |
| <i>Table 5 Input Characteristics*</i> | 15 |
| <i>Table 6 Power Supply Rejection Ratio for VDD = VDDO = 3.3V*</i> | 15 |
| <i>Table 7 Power Supply Rejection Ratio for VDD = VDDO = 2.5V*</i> | 16 |
| <i>Table 8 HCSL Outputs for VDDO = 3.3V*</i> | 17 |
| <i>Table 9 HCSL (PCIe) Jitter Performance for VDDO = 3.3V</i> | 18 |
| <i>Table 10 HCSL Outputs for VDDO = 2.5V*</i> | 19 |
| <i>Table 11 HCSL (PCIe) Jitter Performance for VDDO = 2.5V</i> | 20 |
| <i>Table 12 4x4mm QFN Package Thermal Properties</i> | 23 |

Pin Diagram

The device is packaged in a 4x4mm 20-pin QFN.

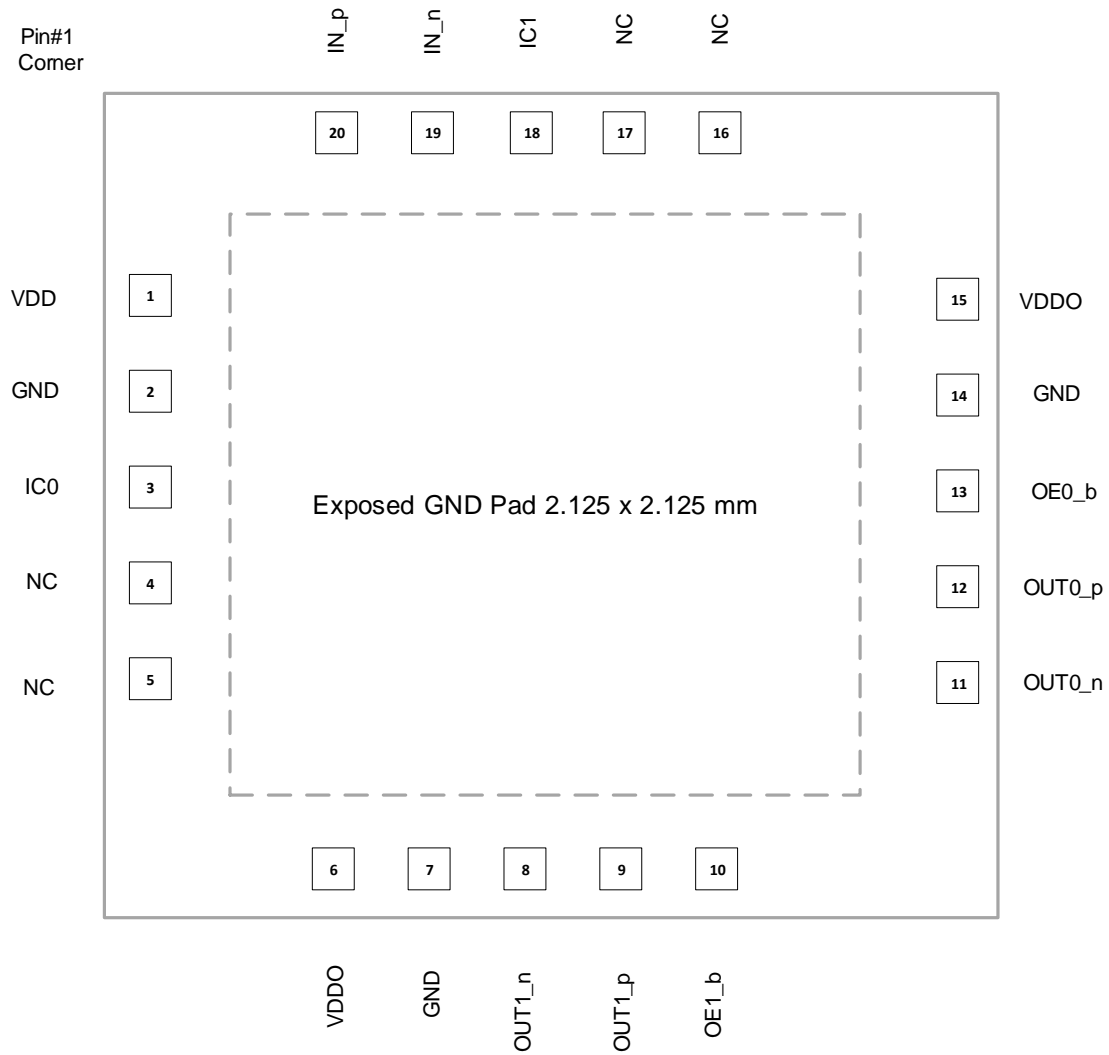

Figure 2. Pin Diagram

Pin Descriptions

All device inputs and outputs are HCSL unless described otherwise. The I/O column uses the following symbols: I – input, I_{PU} – input with 300kΩ internal pull-up resistor, I_{PD} – input with 300kΩ internal pull-down resistor, I_{APU} – input with 31kΩ internal pull-up resistor, I_{APD} – input with 30kΩ internal pull-down resistor, I_{APU/APD} – input biased to VDD/2 with 60kΩ internal pull-up and pull-down resistors (30 kΩ equivalent), O – output, I/O – Input/Output pin, NC-No connect pin, P – power supply pin.

Table 1 Pin Descriptions

| # | Name | I/O | Description | | | | | | |
|-------------------------|--|--|--|-------|----------|---|--------|---|--|
| Input Reference | | | | | | | | | |
| 20 19 | IN_p IN_n | I _{APD} I _{APU/APD} I _{APD} I _{APU/APD} | <p>Input Differential or Single Ended Reference</p> <p>Input frequency range 0Hz to 400MHz.</p> <p>Non-inverting inputs (_p) are pulled down with internal 30kΩ pull-down resistors. Inverting inputs (_n) are pulled up and pulled down with 60kΩ internal resistors (30kΩ equivalent) to keep inverting input voltages at VDD/2 when inverting inputs are left floating (device fed with a single ended reference).</p> | | | | | | |
| Output Clocks | | | | | | | | | |
| 12 11 9 8 | OUT0_p OUT0_n OUT1_p OUT1_n | O | <p>Ultra-Low Additive Jitter Differential HCSL Outputs 0 to 1</p> <p>Output frequency range 0 to 400MHz</p> | | | | | | |
| Control | | | | | | | | | |
| 13 10 | OE0_b OE1_b | I _{PD} | <p>Output Enable. Logic level on these pins enables/disables corresponding outputs.</p> <table border="1"> <thead> <tr> <th>OEn_b</th> <th>OUTn_p/n</th> </tr> </thead> <tbody> <tr> <td>0</td> <td>Active</td> </tr> <tr> <td>1</td> <td>High-Z (outputs p/n will be low/low because of 50Ω shunt resistors—see recommended output termination)</td> </tr> </tbody> </table> | OEn_b | OUTn_p/n | 0 | Active | 1 | High-Z (outputs p/n will be low/low because of 50Ω shunt resistors—see recommended output termination) |
| OEn_b | OUTn_p/n | | | | | | | | |
| 0 | Active | | | | | | | | |
| 1 | High-Z (outputs p/n will be low/low because of 50Ω shunt resistors—see recommended output termination) | | | | | | | | |
| Power and Ground | | | | | | | | | |

| | | | |
|--------------------|------------|-----------------|---|
| 1 | VDD | P | Positive Supply Voltage. Connect to 3.3V or 2.5V supply. |
| 6 15 | VDDO | P | Positive Supply Voltage for Differential Outputs Connect 3.3V or 2.5V power supply. VDDO does not have to be connected to the same voltage level as VDD. |
| 3 18 | IC0 IC1 | I _{PD} | Internal Connection For normal operation connect to VDD or pull-up with 1kΩ resistor. |
| 4 5 16 17 | NC | NC | No Connect Leave open |
| 2 7 14 | GND | P | Ground Connect to the ground |
| E-Pad | GND | P | Ground. Connect to the ground |

Functional Description

The ZL40262 is an ultra-low additive jitter, low power 1 to 2 HCSL fanout buffer.

The device operates from 2.5V+/-5% or 3.3V+/-5% supply. Its operation is guaranteed over the industrial temperature range -40°C to +85°C.

Clock Inputs

The following blocks diagram shows how to terminate different signals fed to the ZL40262 inputs.

Figure 3 and Figure 4 show how to terminate the input when driven from an HCSL driver.

The input buffer in ZL40262 is a native HCSL receiver so other differential formats need to be AC coupled as shown in Figure 5 and Figure 6 for LVPECL and LVDS signals respectively.

Figure 7 shows how to terminate a single ended output such as LVCMOS. Ideally, resistors R1 and R2 should be 100Ω each and R_o + R_s should be 50Ω so that the transmission line is terminated at both ends with characteristic impedance. If the driving strength of the output driver is not sufficient to drive low impedance, the value of series resistor R_s should be increased. This will reduce the voltage swing at the input but this should be fine as long as the input voltage swing requirement is not violated (Table 5). The source resistors of R_s = 270Ω could be used for standard LVCMOS driver. This will provide 516mV of voltage swing for 3.3V LVCMOS driver with load current of $(3.3V/2) * (1/(270\Omega + 50\Omega)) = 5.16mA$.

For optimum performance both differential input pins (_p and _n) need to be DC biased to the same voltage. Hence, the ratio R1/R2 should be equal to the ratio R3/R4.

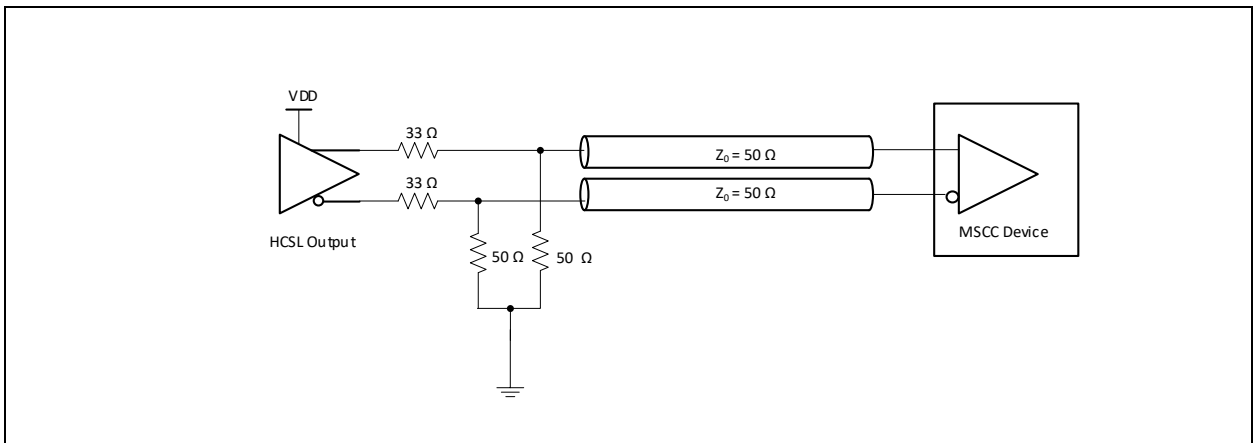

Figure 3. Input driven by source terminated HCSL

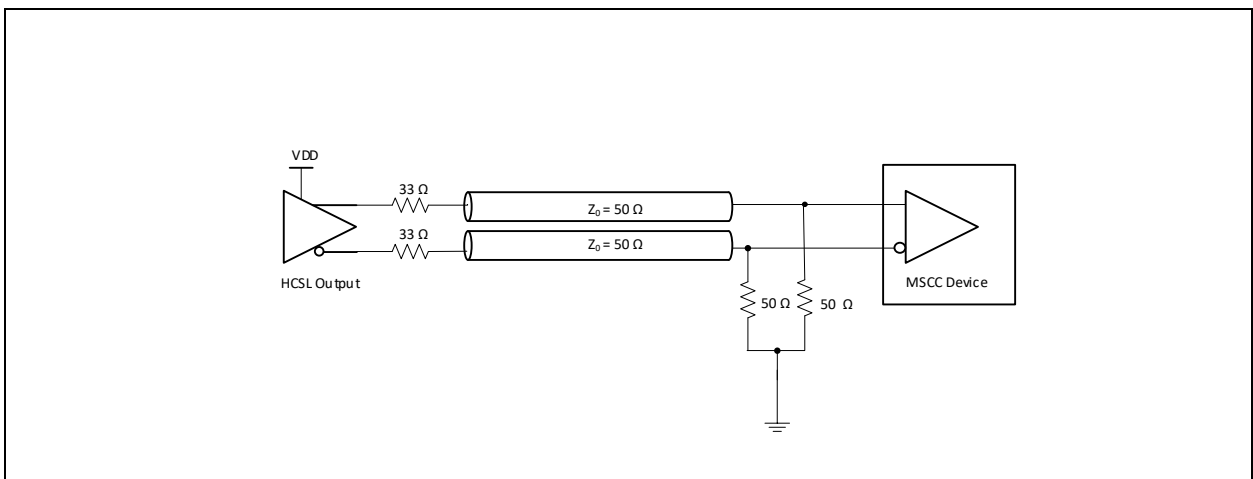

Figure 4. Input driven by receiver terminated HCSL

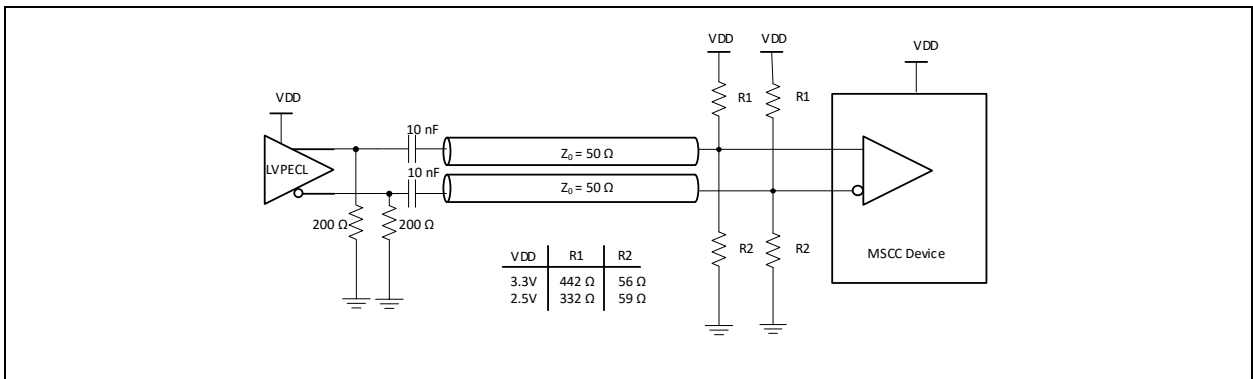

Figure 5. Input driven by AC coupled LVPECL output

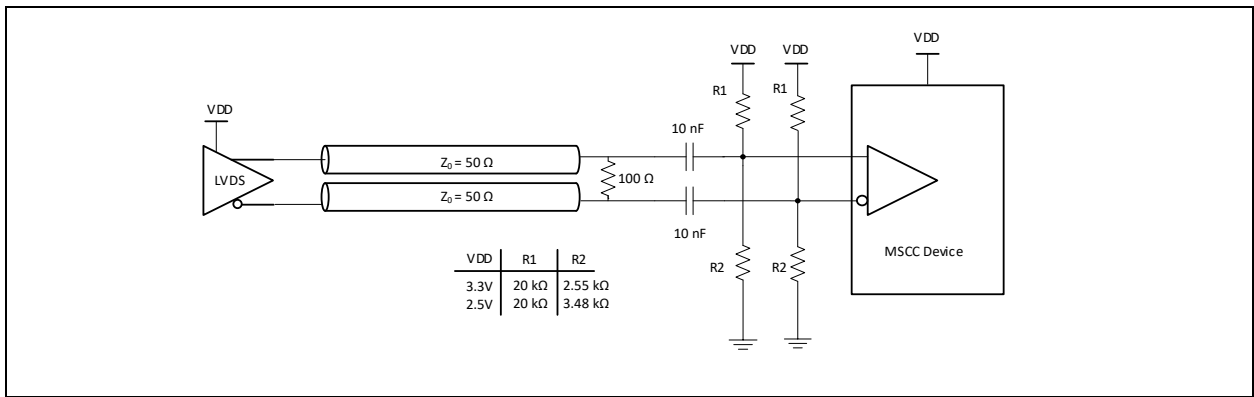

Figure 6. Input driven by AC coupled LVDS

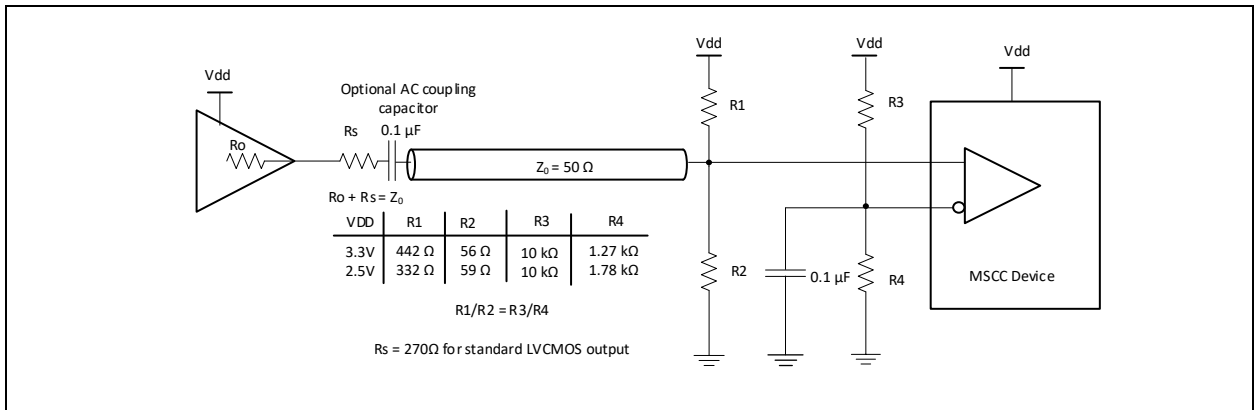

Figure 7. Input driven by a single ended output

Clock Outputs

Differential HCSL outputs should be terminated as shown in Figure 8 or Figure 9.

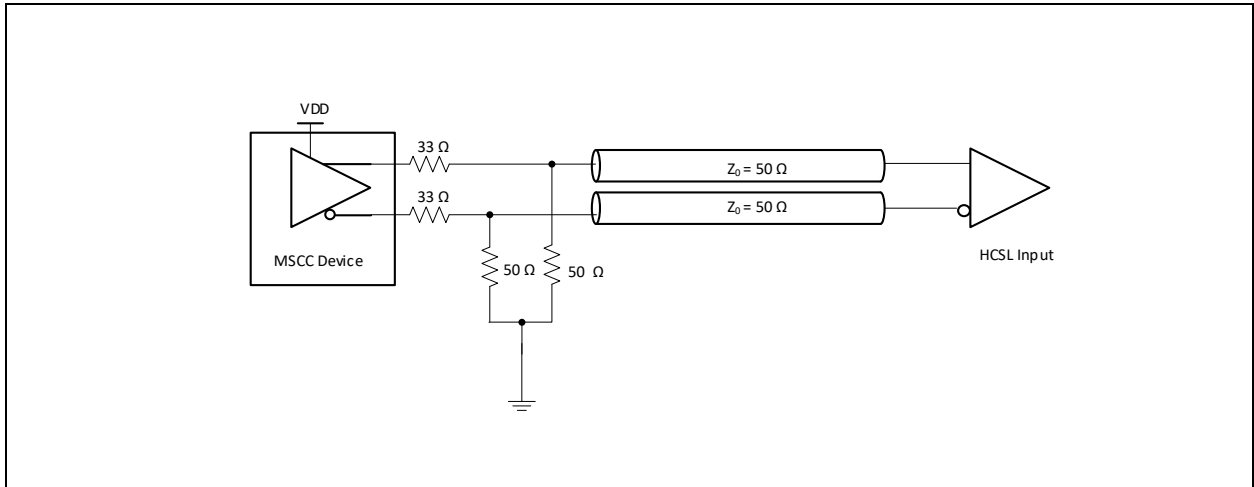

Figure 8. Source terminated HCSL

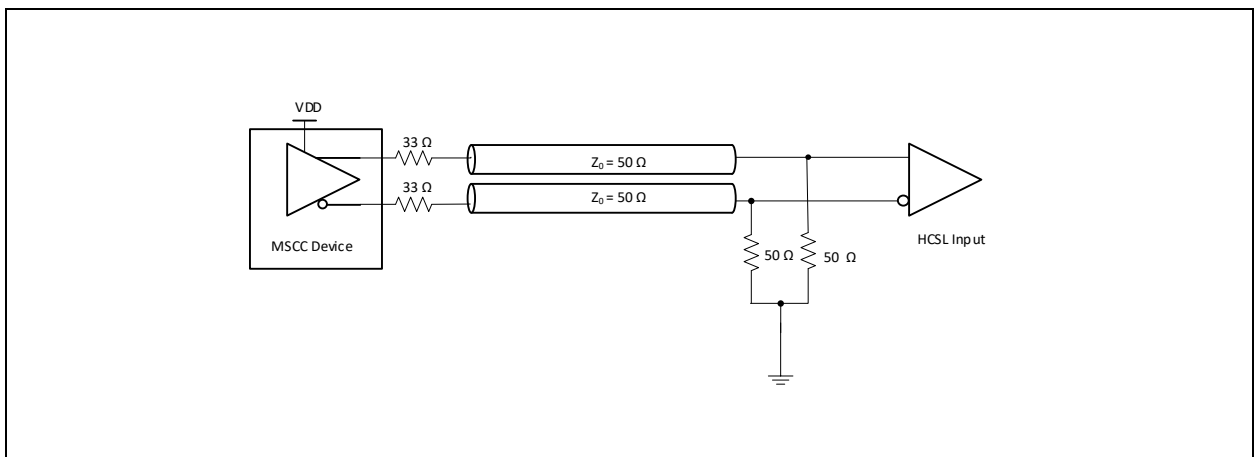

Figure 9. Receiver terminated HCSL

Termination of unused outputs

Unused outputs should be left unconnected.

Power Consumption

The device total power consumption can be calculated as:

$$P_T = P_S + P_C + P_{O_DIFF}$$

Where:

$$P_S = V_{DD} * I_S$$

Core power consumed by the input buffer. The static current (I_S) is specified in Table 4.

$$P_C = V_{DDO} * I_{DD_CM}$$

Common output power shared between two outputs. The current I_{DD_CM} is specified in Table 4.

$$P_{O_DIF} = V_{DDO} * I_{DD_HCSL} * N$$

Output power where output current per output (I_{DD_HCSL}) is specified in Table 4.

N is number of enabled outputs.

Power dissipated inside the device can be calculated by subtracting power dissipated in termination/biasing resistors from the power consumption:

$$P_D = P_T - N * P_{HCSL}$$

Where:

$$P_{HCSL} = (V_{SW} / 50\Omega)^2 * (50\Omega + 33\Omega)$$

V_{SW} is voltage swing of HCSL output. 50Ω is termination resistance and 33Ω is series resistance of the HCSL output.

Power Supply Filtering

Each power pin (VDD and VDDO) should be decoupled with $0.1\mu\text{F}$ capacitor with minimum equivalent series resistance (ESR) and minimum series inductance (ESL). For example, 0402 X5R Ceramic Capacitors with 6.3V minimum rating could be used. These capacitors should be placed as close as possible to the power pins. To reduce the power noise from adjacent digital components on the board each power supply could optionally be further insulated with low resistance ferrite bead with $10\mu\text{F}$ and $1\mu\text{F}$ capacitors. Following figure shows the standard and optional decoupling method.

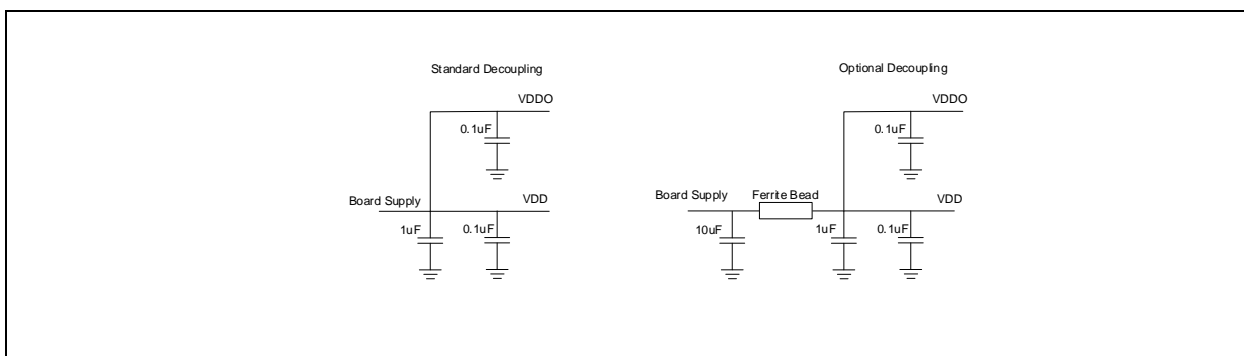

Figure 10. Power Supply Filtering

Power Supplies and Power-up Sequence

The device has two different power supplies: VDD and VDDO which should always be connected to the same voltage supply. Voltages supported by each of these power supplies are specified in Table 3.

VDD and VDDO should always be turned on and off at the same time.

Device Control

ZL40262 outputs are controlled via OE[1:0]_b pins. When an OE_b pin is low the corresponding outputs will be active and when this pin is high the output will be high-Z. When the output driver is in high-Z mode, the output pins will be pulled low via external 50Ω HCSL termination resistors.

Typical phase noise performance

The following plots show typical phase noise performance for 100 MHz, 133 MHz and 400 MHz respectively.

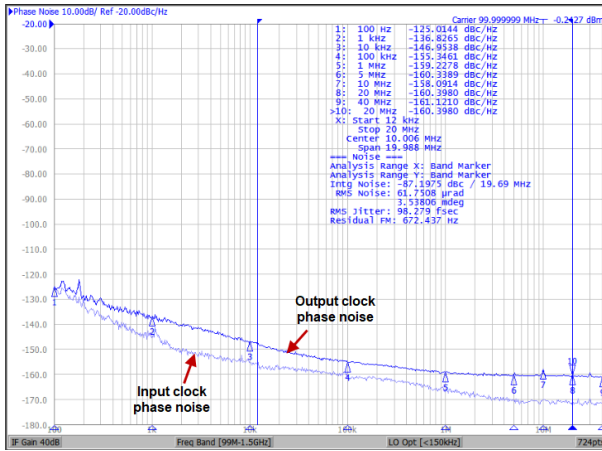

Figure 11. 100MHz HCSL Phase Noise

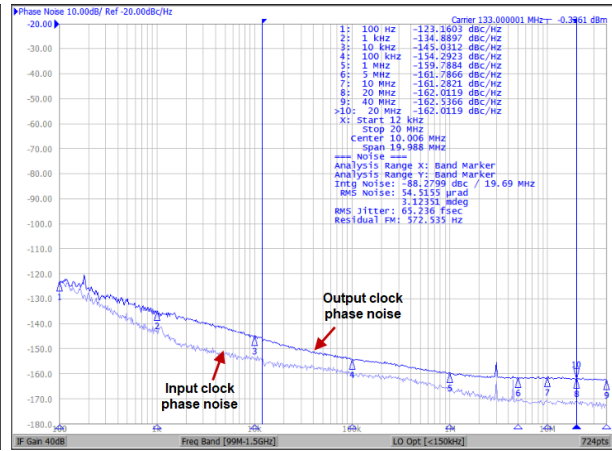

Figure 12. 133MHz HCSL Phase Noise

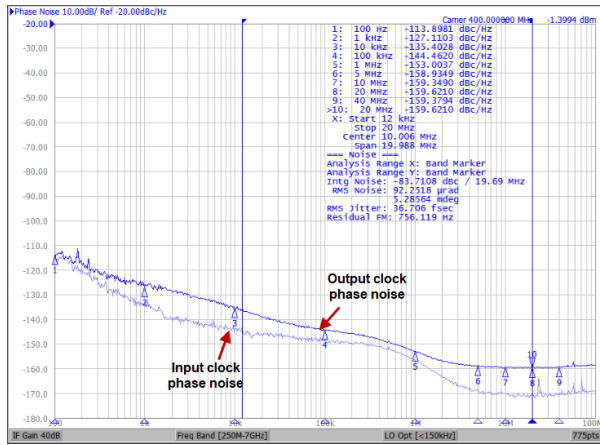

Figure 13. 400MHz HCSL Phase Noise

AC and DC Electrical Characteristics

Absolute Maximum Ratings

Table 2 Absolute Maximum Ratings*

| | Parameter | Sym. | Min. | Typ. | Max. | Units | Notes |
|---|-----------------------|------------------|------|------|------|-------|-------|
| 1 | Supply voltage (3.3V) | V_{DD}/V_{DDO} | -0.5 | | 4.6 | V | |
| 2 | Supply voltage (2.5V) | V_{DD}/V_{DDO} | -0.5 | | 3.5 | V | |
| 3 | Storage temperature | T_{ST} | -55 | | 125 | °C | |

* Exceeding these values may cause permanent damage

* Functional operation under these conditions is not implied

* Voltages are with respect to ground (GND) unless otherwise stated

Recommended Operating Conditions

Table 3 Recommended Operating Conditions*

| | Characteristics | Sym. | Min. | Typ. | Max. | Units | Notes |
|---|-----------------------|------------------|-------|------|----------------|-------|-------|
| 1 | Supply voltage 3.3V | V_{DD}/V_{DDO} | 3.135 | 3.30 | 3.465 | V | |
| 2 | Supply voltage 2.5V | V_{DD}/V_{DDO} | 2.375 | 2.50 | 2.625 | V | |
| 5 | Operating temperature | T_A | -40 | 25 | 85 | °C | |
| 6 | Input voltage | V_{DD-IN} | -0.3 | | $V_{DD} + 0.3$ | V | |

* Voltages are with respect to ground (GND) unless otherwise stated

* The device core supports two power supply modes (3.3V and 2.5V)

Table 4 Current consumption

| | Characteristics | Sym. | Min. | Typ. | Max. | Units | Notes |
|---|-------------------------------------|----------------------|------|-------|-------|-------|---------------|
| 1 | Core device current | $I_{s_3.3V}$ | | 49 | 53 | mA | VDD= 3.3V+5% |
| | | $I_{s_2.5V}$ | | 48 | 53 | mA | VDD = 2.5V+5% |
| 2 | Common output current | $I_{DD_CM_3.3V}$ | | 5.24 | 5.82 | mA | VDDO= 3.3V+5% |
| | | $I_{DD_CM_2.5V}$ | | 4.72 | 5.32 | mA | VDDO= 2.5V+5% |
| 3 | Current dissipation per HCSL output | $I_{DD_HCSL_3.3V}$ | | 14.92 | 17.18 | mA | VDDO= 3.3V+5% |
| | | $I_{DD_HCSL_2.5V}$ | | 14.61 | 16.62 | mA | VDDO= 2.5V+5% |

Table 5 Input Characteristics*

| | Characteristics | Sym. | Min. | Typ. | Max. | Units | Notes |
|----|---|-----------------|----------------|------|-----------------|------------|---------------------|
| 1a | CMOS high-level input voltage for control inputs | $V_{CH_3.3V}$ | $0.7 * V_{DD}$ | | | V | $V_{DD} = 3.3V$ |
| 1b | CMOS high-level input voltage for control inputs | $V_{CH_2.5V}$ | $0.8 * V_{DD}$ | | | V | $V_{DD} = 2.5V$ |
| 2 | CMOS low-level input voltage for control inputs | V_{CIL} | | | $0.32 * V_{DD}$ | V | |
| 3 | CMOS input leakage current for control inputs (includes current due to pull down resistors) | I_{IL} | -25 | | 50 | μA | $V_i = V_{DD}$ or 0 |
| 4 | Differential input common mode voltage for IN_p/n | V_{CM} | 0.1 | | 0.8 | V | |
| 5 | Differential input voltage for IN_p/n | V_{ID} | 0.2 | | $V_{DD} + 0.3$ | V | |
| 6 | Differential input leakage current for IN_p/n (includes current due to pull-up and pull-down resistors) | I_{IL} | -150 | | 150 | μA | $V_i = 2V$ or 0V |
| 7 | Single ended input voltage for IN_p | V_{SI} | -0.3 | | 2.7 | V | VDD = 3.3V or 2.5V |
| 8 | Single ended input common mode voltage IN_p | V_{SIC} | 0.1 | | 0.8 | V | VDD = 3.3V or 2.5V |
| 9 | Single ended input voltage swing for IN_p | V_{SID} | 0.3 | | 1.3 | V | VDD = 3.3V or 2.5V |
| 10 | Input frequency (differential) | f_{IN} | 0 | | 400 | MHz | |
| 11 | Input duty cycle | dc | 35% | | 65% | | |
| 13 | Input slew rate | slew | 0.6 | 2 | | V/ns | |
| 14 | Input pull-up/ pull-down resistance | R_{PU}/R_{PD} | | 60 | | k Ω | |
| 15 | Input pull-down resistance for IN_p | R_{PD} | | 30 | | k Ω | |
| 16 | Control input (OE_b) pull-down resistance | R_{PDOE} | | 300 | | k Ω | |

* Values are over Recommended Operating Conditions

* Values are over all two power supply modes ($V_{DD} = 3.3V$ and $V_{DD} = 2.5V$)

(1) low frequency only

Table 6 Power Supply Rejection Ratio for VDD = VDDO = 3.3V*

| | Characteristics | Sym. | Min. | Typ. | Max. | Units | Notes |
|---|----------------------|---------------|------|-------|------|-------|--------------------|
| 1 | PSRR for HCSL output | $PSRR_{HCSL}$ | | -80.7 | | dBc | $f_{IN} = 100$ MHz |
| | | | | -76.4 | | | $f_{IN} = 133$ MHz |
| | | | | -66.5 | | | $f_{IN} = 400$ MHz |

* Values are over Recommended Operating Conditions

* Noise injected to VDD/VDDO power supply with frequency 100 kHz and amplitude 100 mVpp

* PSRR is measured as amplitude of 100 kHz spur in dBc on the output clock phase noise plot

Table 7 Power Supply Rejection Ratio for VDD = VDDO = 2.5V*

| | Characteristics | Sym. | Min. | Typ. | Max. | Units | Notes |
|---|----------------------|----------------------|------|-------|------|-------|---------------------------|
| 3 | PSRR for HCSL output | PSRR _{HCSL} | | -73.5 | | dBc | f _{IN} = 100 MHz |
| | | | | -69.8 | | | f _{IN} = 133 MHz |
| | | | | -61.2 | | | f _{IN} = 400 MHz |

* Values are over Recommended Operating Conditions

* Noise injected to VDD/VDDO power supply with frequency 100 kHz and amplitude 100 mVpp

* PSRR is measured as amplitude of 100 kHz spur in dBc on the output clock phase noise plot

Table 8 HCSL Outputs for VDDO = 3.3V*

| | Parameter | Sym. | Min. | Typ. | Max. | Units | Notes |
|----|---|-----------------------|-------|-------|-------|-----------------|--------------------------|
| 1 | Rising edge rate | Rise_rate | 1.3 | 1.7 | 2 | V/ns | (2), (3) |
| 2 | Falling edge rate | Fall_rate | 1.3 | 1.7 | 2 | V/ns | (2), (3) |
| 3 | Differential High Voltage | V _{IH} | 0.6 | | 0.9 | V | (2) |
| 4 | Differential Low Voltage | V _{IL} | -0.9 | | -0.6 | V | (2) |
| 5 | Single ended high voltage | V _{SIH} | 0.6 | 0.74 | 0.85 | V | DC Measurement |
| 6 | Single ended low voltage | V _{SIL} | -0.01 | 0 | 0.01 | V | DC Measurement |
| 7 | Absolute Crossing Voltage | V _{CROSS} | 0.26 | 0.32 | 0.38 | V | (1), (4), (5) |
| 8 | Variation of V _{CROSS} over all rising clock edges | ΔV _{CROSS} | 0.039 | 0.050 | 0.061 | V | (1), (4), (9) |
| 9 | Ring back voltage margin | V _{RB} | 0.534 | 0.674 | 0.809 | V | (2), (11) |
| 10 | Time before V _{RB} is allowed | t _{STABLE} | 4.6 | | | ns | (2), (11) |
| 11 | Cycle-to-cycle additive jitter | T _{JCC} | | 6.5 | 8.1 | ps peak to peak | (2) |
| 12 | Absolute Maximum voltage | V _{MAX} | | | 0.92 | | (1), (7) |
| 13 | Absolute Minimum voltage | V _{MIN} | -0.05 | | | | (1), (8) |
| 14 | Output Duty-Cycle (when input has 50% duty-cycle) | Duty_cycle | 48 | 50 | 52 | % | (2) |
| 15 | Rising to falling edge matching | r/f match | | | 15 | % | (1), (12) |
| 16 | Clock Source DC impedance (CK) | Z _{C-DC,CK} | 49 | 50 | 51 | Ω | DC Measurement (1), (13) |
| 17 | Clock Source DC impedance (CK#) | Z _{C-DC,CK#} | 49 | 50 | 51 | Ω | DC Measurement (1), (13) |
| 18 | Output frequency | F _{MAX} | 0 | | 400 | MHz | |
| 19 | Output to output skew | t _{OOSK} | | | 50 | ps | |
| 20 | Device to device output skew | t _{DOOSK} | | | 129 | ps | |
| 21 | Input to output delay | t _{IOD} | 0.75 | 0.84 | 1 | ns | |
| 22 | Output enable time | t _{EN} | | | 3 | cycles | |
| 23 | Output disable time | t _{DIS} | | | 3 | cycles | |

* Values are over Recommended Operating Conditions

(1) Measurement taken from single ended waveform

(2) Measurement taken from differential waveform.

(3) Measured from -150 mV to +150 mV on the differential waveform (derived from CK minus CK#) The signal must be monotonic through the measurement region for rise and fall time. The 300 mV measurement window is centered on the differential zero crossing. See Figure 17

(4) Measured at crossing point where the instantaneous voltage value of the rising edge of CK equals the falling edge of CK# . See Figure 14

(5) Refers to the total variation from the lowest crossing point to the highest, regardless of which edge is crossing. Refers to all crossing points for this measurement. See Figure 14.

(6) This requirement, from PCI Express Base Specification, Revision 4.0 is applicable only to clock generators and not to buffers. A clock buffer is a transparent device whose output clock period follows the input clock period.

(7) Defined as the maximum instantaneous voltage including overshoot. See Figure 14.

(8) Defined as the minimum instantaneous voltage including undershoot. See Figure 14.

(9) Defined as the total variation of all crossing voltages of Rising CK and Falling CK# This is the maximum allowed variance in VCROSS for any particular system. See Figure 15.

(10) The PPM requirement from PCIe Express Base Specification, Revision 4.0 is related to clock generation devices. This requirement is not applicable to buffers because buffer's output frequency accuracy is identical to the frequency accuracy of the source driving the buffer.

(11) T_{STABLE} is the time the differential clock must maintain a minimum ±150 mV differential voltage after 20 rising/falling edges before it is allowed to droop back into the V_{RB} ±100 mV differential range. See Figure 18.

(12) Matching applies to rising edge rate for CK_x and falling edge rate for CK#_x. It is measured using a ±75 mV window centered on the median cross point where CK_x rising meets CK#_x falling. The median cross point is used to calculate the voltage thresholds the oscilloscope is to use for the edge rate calculations. The Rise Edge Rate of CK_x should be compared to the Fall Edge Rate of CK#_x the maximum allowed difference should not exceed 20% of the slowest edge rate. See Figure 16.

(13) Clock DC impedance tolerance depends only on the tolerance of external 50Ω shunt resistors used in HCSL. The test used resistors with +/-1% tolerance.

Table 9 HCSL (PCIe) Jitter Performance for VDDO = 3.3V

| | Parameter | Sym. | Min. | Typ. | Max. | Units | Notes |
|----|--|------------------------|------|------|------|----------|----------------------|
| 1 | Additive Jitter as per PCIe 1.0 (1.5MHz to 22MHz) | $T_{jPCIe_1.0}$ | | 1.2 | 1.45 | ps pk-pk | Input clock: 100 MHz |
| 2 | Additive Jitter as per PCIe 2.0 high band (1.5MHz to 50MHz) | $T_{jPCIe_2.0_high}$ | | 134 | 163 | fs RMS | Input clock: 100 MHz |
| 3 | Additive Jitter as per PCIe 2.0 low band (10kHz to 1.5MHz) | $T_{jPCIe_2.0_low}$ | | 31 | 48 | fs RMS | Input clock: 100 MHz |
| 4 | Additive Jitter as per PCIe 2.0 mid band (5MHz to 16MHz) | $T_{jPCIe_2.0_mid}$ | | 105 | 130 | fs RMS | Input clock: 100 MHz |
| 5 | Additive Jitter as per PCIe 3.0 (PLL_BW = 2 to 5MHz, CDR = 10MHz) | $T_{jPCIe_3.0}$ | | 33 | 41 | fs RMS | Input clock: 100 MHz |
| 6 | Additive Jitter as per PCIe 4.0 (PLL_BW = 2 to 5MHz, CDR = 10MHz) | $T_{jPCIe_4.0}$ | | 33 | 41 | fs RMS | Input clock: 100 MHz |
| 7 | Additive Jitter as per PCIe 5.0 (PLL_BW = 0.5 to 1.8MHz, CDR for 32 GT/s CC) | $T_{jPCIe_5.0}$ | | 13 | 16 | fs RMS | Input clock: 100 MHz |
| 8 | Additive jitter as per Intel QPI 9.6Gbps | T_{jQPI} | | 61 | 75 | fs RMS | Input clock: 100 MHz |
| 9 | Additive RMS jitter in 1MHz to 20MHz band | T_{j1M_20M} | | 87 | 106 | fs RMS | Input clock: 100 MHz |
| | | | | 56 | 68 | fs RMS | Input clock: 133 MHz |
| | | | | 26 | 34 | fs RMS | Input clock: 400 MHz |
| 10 | Additive RMS jitter in 12kHz to 20MHz band | T_{j12k_20M} | | 91 | 112 | fs RMS | Input clock: 100 MHz |
| | | | | 60 | 75 | fs RMS | Input clock: 133 MHz |
| | | | | 32 | 48 | fs RMS | Input clock: 400 MHz |
| 11 | Noise floor | NF | | -161 | -159 | dBc/Hz | Input clock: 100 MHz |
| | | | | -162 | -161 | dBc/Hz | Input clock: 133 MHz |
| | | | | -160 | -157 | dBc/Hz | Input clock: 400 MHz |

* Values are over Recommended Operating Conditions

Table 10 HCSL Outputs for VDDO = 2.5V*

| | Parameter | Sym. | Min. | Typ. | Max. | Units | Notes |
|----|---|-----------------------|-------|-------|-------|-----------------|--------------------------|
| 1 | Rising edge rate | Rise_rate | 1.3 | 1.6 | 1.9 | V/ns | (2), (3) |
| 2 | Falling edge rate | Fall_rate | 1.3 | 1.6 | 1.9 | V/ns | (2), (3) |
| 3 | Differential High Voltage | V _{IH} | 0.6 | | 0.9 | V | (2) |
| 4 | Differential Low Voltage | V _{IL} | -0.9 | | -0.6 | V | (2) |
| 5 | Single ended high voltage | V _{SIH} | 0.58 | 0.71 | 0.84 | V | DC Measurement |
| 6 | Single ended low voltage | V _{SIL} | -0.01 | 0 | 0.01 | V | DC Measurement |
| 7 | Absolute Crossing Voltage | V _{CROSS} | 0.25 | 0.31 | 0.37 | V | (1), (4), (5) |
| 8 | Variation of V _{CROSS} over all rising clock edges | ΔV _{CROSS} | 0.04 | 0.05 | 0.06 | V | (1), (4), (9) |
| 9 | Ring back voltage margin | V _{RB} | 0.514 | 0.660 | 0.791 | V | (2), (11) |
| 10 | Time before V _{RB} is allowed | t _{STABLE} | 4.6 | | | ns | (2), (11) |
| 11 | Additive Cycle-to-cycle jitter | T _{JCC} | | 5.5 | 7.1 | ps peak to peak | (2) |
| 12 | Absolute Maximum voltage | V _{MAX} | | | 0.90 | | (1), (7) |
| 13 | Absolute Minimum voltage | V _{MIN} | -0.05 | | | | (1), (8) |
| 14 | Output Duty-Cycle (when input has 50% duty-cycle) | Duty_cycle | 48 | 50 | 52 | % | (2) |
| 15 | Rising to falling edge matching | r/f match | | | 15 | % | (1), (12) |
| 16 | Clock Source DC impedance (CK) | Z _{C-DC_CK} | 49 | 50 | 51 | Ω | DC Measurement (1), (13) |
| 17 | Clock Source DC impedance (CK#) | Z _{C-DC_CK#} | 49 | 50 | 51 | Ω | DC Measurement (1), (13) |
| 18 | Output frequency | F _{MAX} | 0 | | 400 | MHz | |
| 19 | Output to output skew | t _{OOSK} | | | 50 | ps | |
| 20 | Device to device output skew | t _{DOOSK} | | | 129 | ps | |
| 21 | Input to output delay | t _{IOD} | 0.75 | 0.85 | 1 | ns | |
| 22 | Output enable time | t _{EN} | | | 3 | cycles | |
| 23 | Output disable time | t _{DIS} | | | 3 | cycles | |

* Values are over Recommended Operating Conditions

(1) Measurement taken from single ended waveform

(2) Measurement taken from differential waveform.

(3) Measured from -150 mV to +150 mV on the differential waveform (derived from CK minus CK#) The signal must be monotonic through the measurement region for rise and fall time. The 300 mV measurement window is centered on the differential zero crossing. See Figure 17

(4) Measured at crossing point where the instantaneous voltage value of the rising edge of CK equals the falling edge of CK#. See Figure 14

(5) Refers to the total variation from the lowest crossing point to the highest, regardless of which edge is crossing. Refers to all crossing points for this measurement. See Figure 14.

(6) This requirement, from PCI Express Base Specification, Revision 4.0 is applicable only to clock generators and not to buffers. A clock buffer is a transparent device whose output clock period follows the input clock period.

(7) Defined as the maximum instantaneous voltage including overshoot. See Figure 14.

(8) Defined as the minimum instantaneous voltage including undershoot. See Figure 14.

(9) Defined as the total variation of all crossing voltages of Rising CK and Falling CK# This is the maximum allowed variance in VCROSS for any particular system. See Figure 15.

(10) The PPM requirement from PCIe Express Base Specification, Revision 4.0 is related to clock generation devices. This requirement is not applicable to buffers because buffer's output frequency accuracy is identical to the frequency accuracy of the source driving the buffer.

(11) T_{STABLE} is the time the differential clock must maintain a minimum ±150 mV differential voltage after 20 rising/falling edges before it is allowed to droop back into the V_{RB} ±100 mV differential range. See Figure 18.

(12) Matching applies to rising edge rate for CKx and falling edge rate for CK#x. It is measured using a ±75 mV window centered on the median cross point where CKx rising meets CK#x falling. The median cross point is used to calculate the voltage thresholds the oscilloscope is to use for the edge rate calculations. The Rise Edge Rate of CKx should be compared to the Fall Edge Rate of CK#x the maximum allowed difference should not exceed 20% of the slowest edge rate. See Figure 16.

(13) Clock DC impedance tolerance depends only on the tolerance of external 50Ω shunt resistors used in HCSL. The test used resistors with +/-1% tolerance.

Table 11 HCSL (PCIe) Jitter Performance for VDDO = 2.5V

| | Parameter | Sym. | Min. | Typ. | Max. | Units | Notes |
|----|--|-----------------------------|------|------|------|----------|----------------------|
| 1 | Additive Jitter as per PCIe 1.0 (1.5MHz to 22MHz) | T _{JPCIe_1.0} | | 1.03 | 1.27 | ps pk-pk | Input clock: 100MHz |
| 2 | Additive Jitter as per PCIe 2.0 high band (1.5MHz to 50MHz) | T _{JPCIe_2.0_high} | | 115 | 143 | fs RMS | Input clock: 100MHz |
| 3 | Additive Jitter as per PCIe 2.0 low band (10kHz to 1.5MHz) | T _{JPCIe_2.0_low} | | 28 | 46 | fs RMS | Input clock: 100MHz |
| 4 | Additive Jitter as per PCIe 2.0 mid band (5MHz to 16MHz) | T _{JPCIe_2.0_mid} | | 91 | 113 | fs RMS | Input clock: 100MHz |
| 5 | Additive Jitter as per PCIe 3.0 (PLL_BW = 2 to 5MHz, CDR = 10MHz) | T _{JPCIe_3.0} | | 29 | 36 | fs RMS | Input clock: 100MHz |
| 6 | Additive Jitter as per PCIe 4.0 (PLL_BW = 2 to 5MHz, CDR = 10MHz) | T _{JPCIe_4.0} | | 29 | 36 | fs RMS | Input clock: 100MHz |
| 7 | Additive Jitter as per PCIe 5.0 (PLL_BW = 0.5 to 1.8MHz, CDR for 32 GT/s CC) | T _{JPCIe_4.0} | | 11 | 14 | fs RMS | Input clock: 100MHz |
| 8 | Additive jitter as per Intel QPI 9.6Gbps | T _{JQPI} | | 53 | 67 | fs RMS | Input clock: 100MHz |
| 9 | Additive RMS jitter in 1MHz to 20MHz band | T _{J_1M_20M} | | 75 | 94 | fs RMS | Input clock: 100 MHz |
| | | | | 51 | 64 | fs RMS | Input clock: 133 MHz |
| | | | | 26 | 33 | fs RMS | Input clock: 400 MHz |
| 10 | Additive RMS jitter in 12kHz to 20MHz band | T _{J_12K_20M} | | 79 | 99 | fs RMS | Input clock: 100 MHz |
| | | | | 55 | 68 | fs RMS | Input clock: 133 MHz |
| | | | | 32 | 47 | fs RMS | Input clock: 400 MHz |
| 11 | Noise floor | N _F | | -162 | -159 | dBc/Hz | Input clock: 100 MHz |
| | | | | -163 | -161 | dBc/Hz | Input clock: 133 MHz |
| | | | | -160 | -158 | dBc/Hz | Input clock: 400 MHz |

* Values are over Recommended Operating Conditions

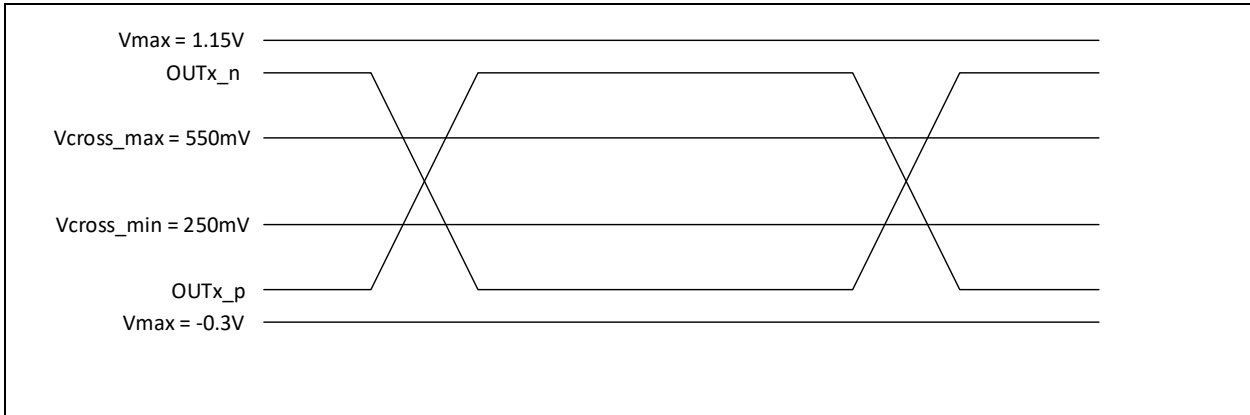

Figure 14. Single-Ended Measurement Points for Absolute Cross Point and Swing

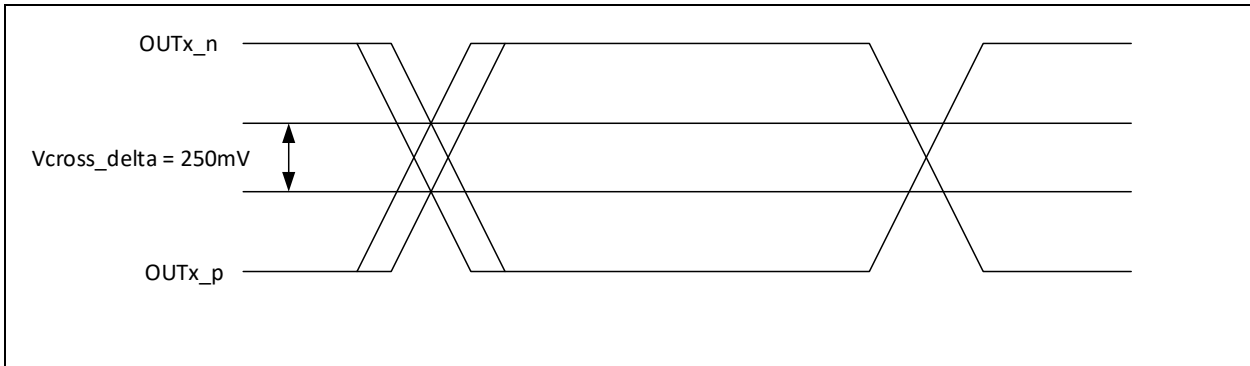

Figure 15. Single-Ended Measurement Points for Delta Cross Point

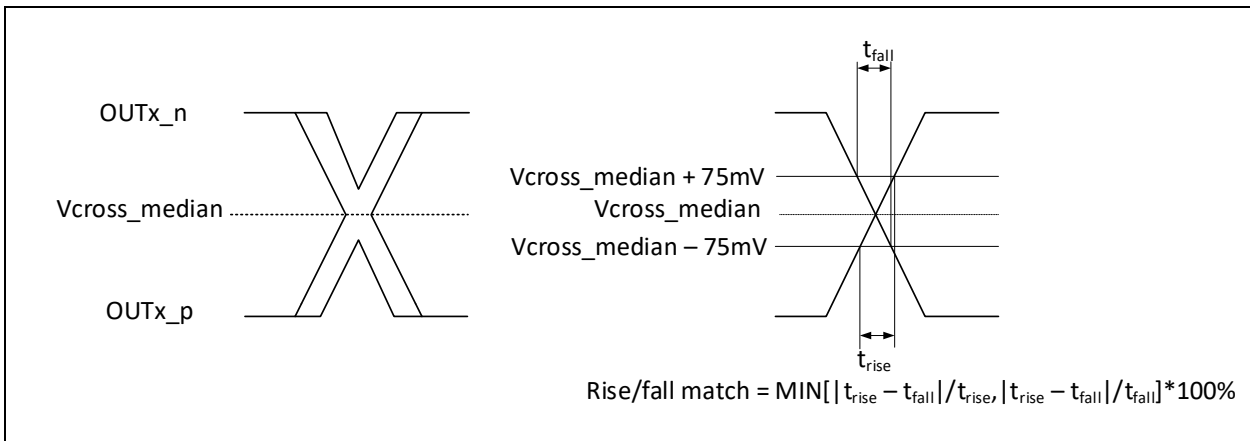

Figure 16. Single-Ended Measurement Points for Rise and Fall Time Matching

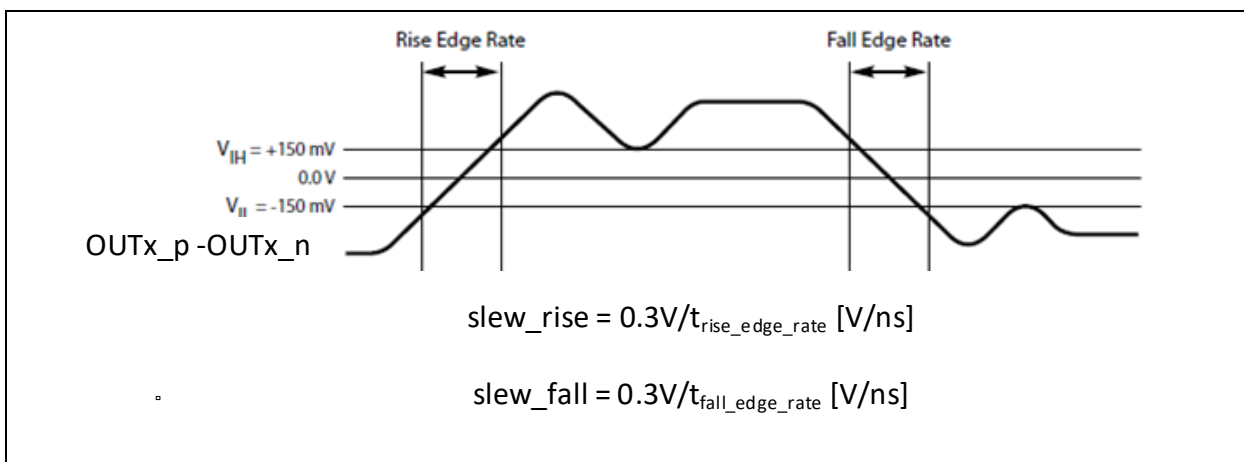

Figure 17. Differential Measurement Points for Rise and Fall Time

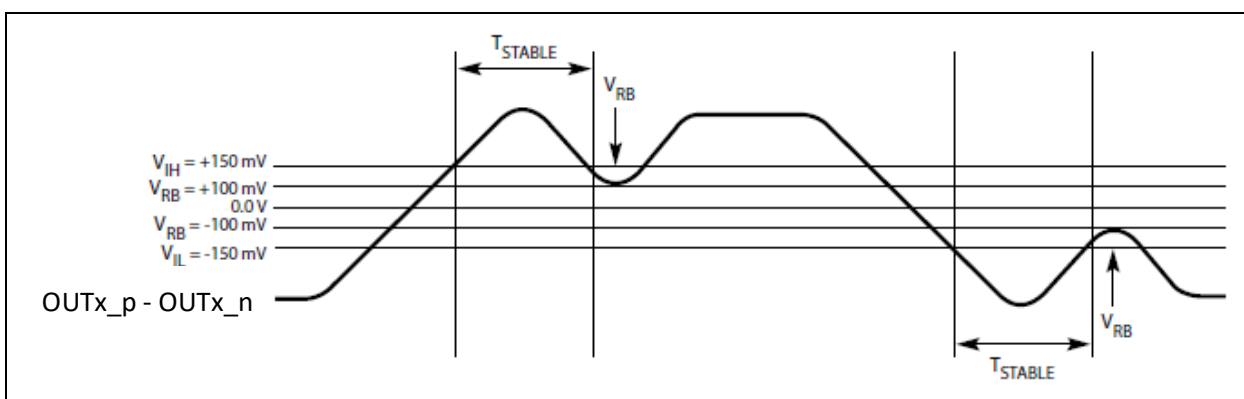

Figure 18. Differential Measurement Points for Ringback

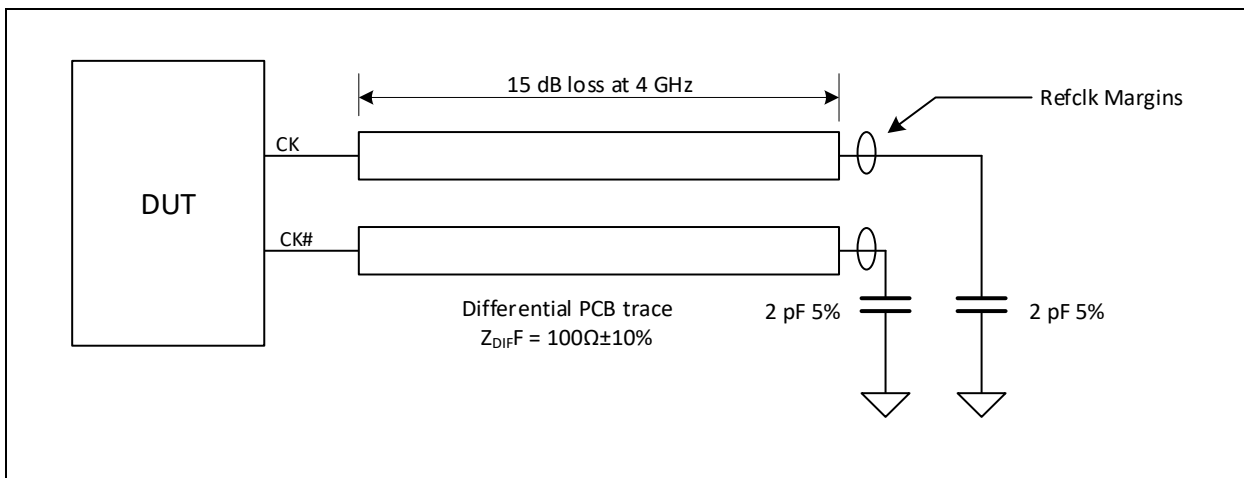

Figure 19. Test Circuit

Table 12 4x4mm QFN Package Thermal Properties

| Parameter | Symbol | Conditions | Value | Units |
|---|---------------|----------------|-------|-------|
| Maximum Ambient Temperature | T_A | | 85 | °C |
| Maximum Junction Temperature | T_{JMAX} | | 125 | °C |
| Junction to Ambient Thermal Resistance ⁽¹⁾ | θ_{JA} | still air | 34 | °C/W |
| | | 1m/s airflow | 28.9 | |
| | | 2.5m/s airflow | 27.0 | |
| Junction to Board Thermal Resistance | θ_{JB} | | 15.4 | °C/W |
| Junction to Case Thermal Resistance | θ_{JC} | | 25.9 | °C/W |
| Junction to Pad Thermal Resistance ⁽²⁾ | θ_{JP} | Still air | 8.1 | °C/W |
| Junction to Top-Center Thermal Characterization Parameter | Ψ_{JT} | Still air | 1.0 | °C/W |

- (1) Theta-JA (θ_{JA}) is the thermal resistance from junction to ambient when the package is mounted on a 4-layer JEDEC standard test board and dissipating maximum power
- (2) Theta-JP (θ_{JP}) is the thermal resistance from junction to the center exposed pad on the bottom of the package)

Package Outline

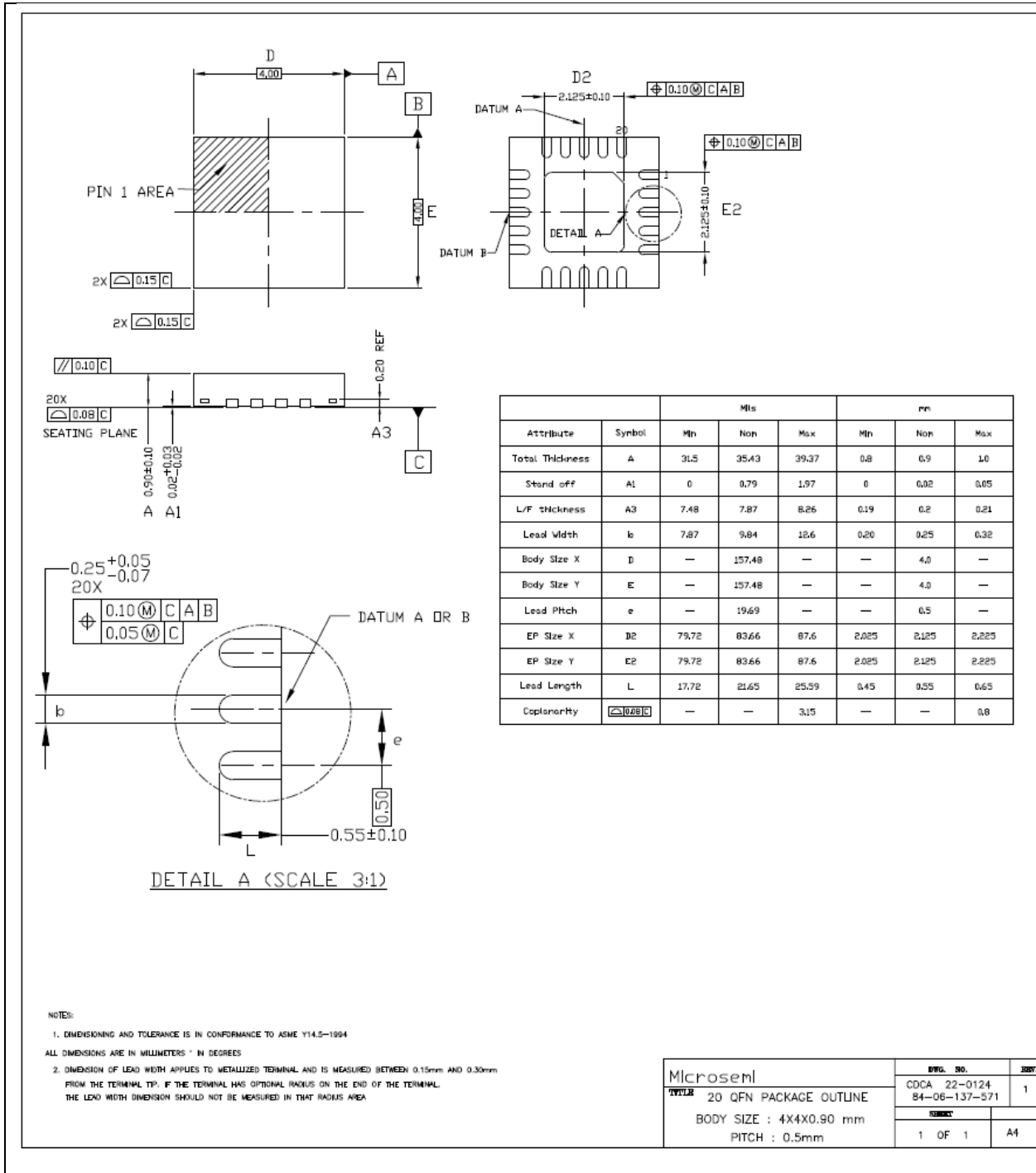

Change history:

June 2019 revision-Initial release



Microsemi Corporate Headquarters
One Enterprise, Aliso Viejo,
CA 92656 USA

Within the USA: +1 (800) 713-4113
Outside the USA: +1 (949) 380-6100
Sales: +1 (949) 380-6136
Fax: +1 (949) 215-4996

E-mail: sales.support@microsemi.com

© 2019 Microsemi Corporation. All rights reserved. Microsemi and the Microsemi logo are trademarks of Microsemi Corporation. All other trademarks and service marks are the property of their respective owners.

Microsemi Corporation (Nasdaq: MSCC) offers a comprehensive portfolio of semiconductor and system solutions for aerospace & defense, communications, data center and industrial markets. Products include high-performance and radiation-hardened analog mixed-signal integrated circuits, FPGAs, SoCs and ASICs; power management products; timing and synchronization devices and precise time solutions, setting the world's standard for time; voice processing devices; RF solutions; discrete components; enterprise storage and communication solutions, security technologies and scalable anti-tamper products; Ethernet solutions; Power-over-Ethernet ICs and midspans; as well as custom design capabilities and services. Microsemi is headquartered in Aliso Viejo, California, and has approximately 4,800 employees globally. Learn more at www.microsemi.com.

Microsemi makes no warranty, representation, or guarantee regarding the information contained herein or the suitability of its products and services for any particular purpose, nor does Microsemi assume any liability whatsoever arising out of the application or use of any product or circuit. The products sold hereunder and any other products sold by Microsemi have been subject to limited testing and should not be used in conjunction with mission-critical equipment or applications. Any performance specifications are believed to be reliable but are not verified, and Buyer must conduct and complete all performance and other testing of the products, alone and together with, or installed in, any end-products. Buyer shall not rely on any data and performance specifications or parameters provided by Microsemi. It is the Buyer's responsibility to independently determine suitability of any products and to test and verify the same. The information provided by Microsemi hereunder is provided "as is, where is" and with all faults, and the entire risk associated with such information is entirely with the Buyer. Microsemi does not grant, explicitly or implicitly, to any party any patent rights, licenses, or any other IP rights, whether with regard to such information itself or anything described by such information. Information provided in this document is proprietary to Microsemi, and Microsemi reserves the right to make any changes to the information in this document or to any products and services at any time without notice.