Features

- Fast Access Time: 30/45 ns
- Wide Temperature Range: -55°C to +125°C
- Separate Upper Byte and Lower Byte Control for Multiplexed Bus Compatibility
- Expandable Data Bus to 32 bits or More Using Master/Slave Chip Select When Using More Than One Device
- On-chip Arbitration Logic
- Versatile Pin Select for Master or Slave:
 - M/S = H for Busy Output Flag On Master
 - M/S = L for Busy Input Flag On Slave
- INT Flag for Port to Port Communication
- Full Hardware Support of Semaphore Signaling Between Ports
- Fully Asynchronous Operation From Either Port
- Battery Back-up Operation: 2V Data Retention
- TTL Compatible
- Single 5V \pm 10% Power Supply
- No Single Event Latch-up below a LET Threshold of 80 MeV/mg/cm²
- Tested up to a Total Dose of 30 krad(Si) according to MIL STD 883 Method 1019
- Quality grades: QML Q and V with SMD 5962-91617 and ESCC with 9301/050

Introduction

The M67025E is a very low power CMOS dual port static RAM organized as 8192 bit \times 16. The product is designed to be used as a stand-alone 16-bit dual port RAM or as a combination MASTER/SLAVE dual port for 32-bit or more width systems. The Atmel MASTER/SLAVE dual port approach in memory system applications results in full speed, error free operation without the need of an additional discrete logic.

Master and slave devices provide two independent ports with separate control, address and I/O pins that permit independent, asynchronous access for reads and writes to any location in the memory. An automatic power down feature controlled by \overline{CS} permits the on-chip circuitry of each port in order to enter a very low stand by power mode.

Using an array of eight transistors (8T) memory cell, the M67025E combines an extremely low standby supply current (typ = 1.0 μ A) with a fast access time at 30 ns over the full temperature range. All versions offer battery backup data retention capability with a typical power consumption at less than 5 μ W.

For military/space applications that demand superior levels of performance and reliability the M67025E is processed according to the methods of the latest revision of the MIL PRF 38635 (Q and V) and/or ESCC 9000.



**Rad. Tolerant
High Speed
8 Kb x 16
Dual Port RAM**

M67025E



Block Diagram

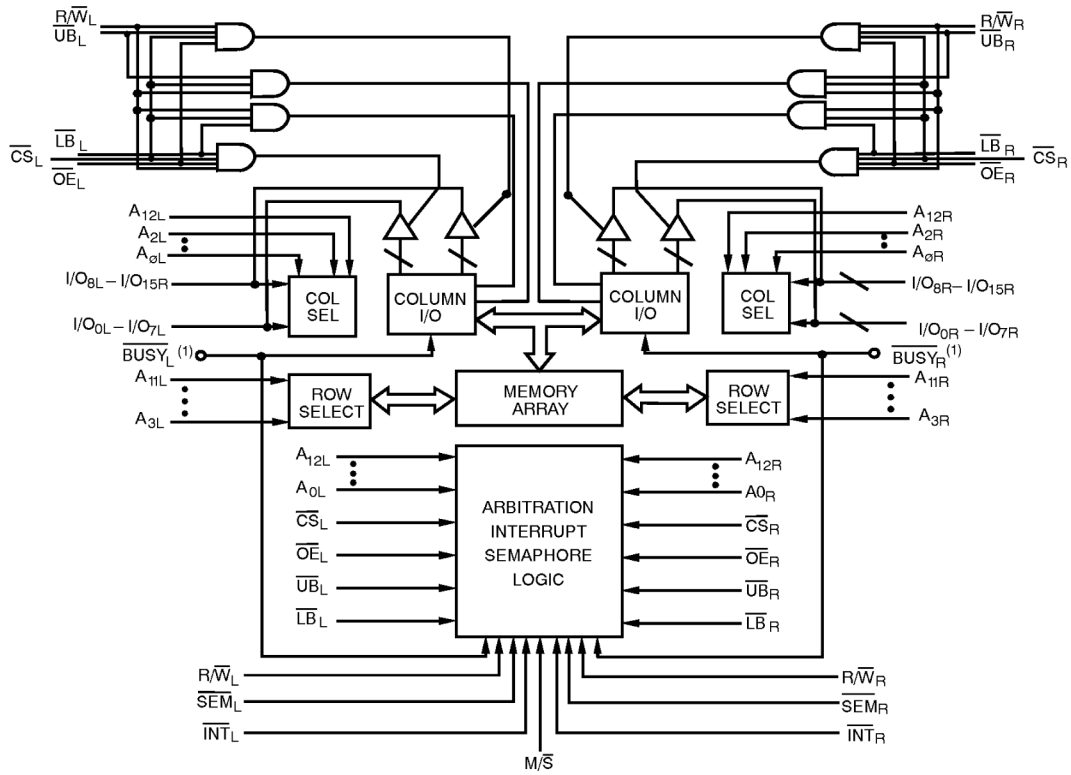

- Notes: 1. (MASTER): $\overline{\text{BUSY}}$ is output. (SLAVE): $\overline{\text{BUSY}}$ is input.
 2. LB = Lower Byte UB = Upper Byte

Pin Configuration

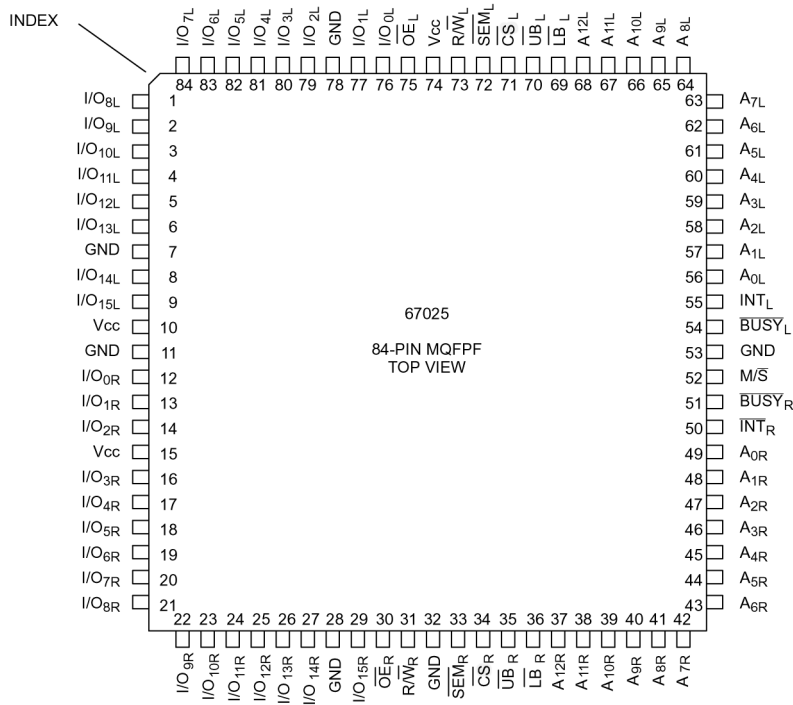

Pin Description

Left Port	Right Port	Names
\overline{CS}_L	\overline{CS}_R	Chip select
R/\overline{W}_L	R/\overline{W}_R	Read/Write Enable
\overline{OE}_L	\overline{OE}_R	Output Enable
$A_{0L} - 12L$	$A_{0R} - 12R$	Address
$I/O_{0L} - 15L$	$I/O_{0R} - 15R$	Data Input/Output
\overline{SEM}_L	\overline{SEM}_R	Semaphore Enable
\overline{UB}_L	\overline{UB}_R	Upper Byte Select
\overline{LB}_L	\overline{LB}_R	Lower Byte Select
\overline{INT}_L	\overline{INT}_R	Interrupt Flag
\overline{BUSY}_L	\overline{BUSY}_R	Busy Flag
	M/ \overline{S}	Master or Slave Select
	Vcc	Power
	GND	Ground

Functional Description

The M67025E has two ports with separate control, address and I/O pins that permit independent read/write access to any memory location. These devices have an automatic power-down feature controlled by \overline{CS} . \overline{CS} controls on-chip power-down circuitry which causes the port concerned to go into stand-by mode when not selected (\overline{CS} high). When a port is selected access to the full memory array is permitted. Each port has its own Output Enable control (\overline{OE}). In read mode, the port's \overline{OE} turns the Output drivers on when set LOW. Non-conflicting READ/WRITE conditions are illustrated in Table 1.

The interrupt flag (\overline{INT}) allows communication between ports or systems. If the user chooses to use the interrupt function, a memory location (mail box or message center) is assigned to each port. The left port interrupt flag (INT_L) is set when the right port writes to memory location 1FFE (HEX). The left port clears the interrupt by reading address location 1FFE. Similarly, the right port interrupt flag (INT_R) is set when the left port writes to memory location 1FFF (HEX), and the right port must read memory location 1FFF in order to clear the interrupt flag (INT_R). The 16-bit message at 1FFE or 1FFF is user-defined. If the interrupt function is not used, address locations 1FFE and 1FFF are not reserved for mail boxes but become part of the RAM. See Table 3 for the interrupt function.

Arbitration Logic

The arbitration logic will resolve an address match or a chip select match down to a minimum of 5 ns determine which port has access. In all cases, an active \overline{BUSY} flag will be set for the inhibited port.

The \overline{BUSY} flags are required when both ports attempt to access the same location simultaneously. Should this conflict arise, on-chip arbitration logic will determine which port has access and set the \overline{BUSY} flag for the inhibited port. \overline{BUSY} is set at speeds that allow the processor to hold the operation with its associated address and data. It should be noted that the operation is invalid for the port for which \overline{BUSY} is set LOW. The inhibited port will be given access when \overline{BUSY} goes inactive.

A conflict will occur when both left and right ports are active and the two addresses coincide. The on-chip arbitration determines access in these circumstances. Two modes of arbitration are provided: (1) if the addresses match and are valid before \overline{CS} on-chip control logic arbitrates between \overline{CS}_L and \overline{CS}_R for access; or (2) if the \overline{CS} are low before an address match, on-chip control logic arbitrates between the left and right addresses for access (refer to Table 4). The inhibited port's \overline{BUSY} flag is set and will reset when the port granted access completes its operation in both arbitration modes.

Data Bus Width Expansion

Expanding the data bus width to 32 or more bits in a dual-port RAM system means that several chips may be active simultaneously. If every chips has a hardware arbitrator, and the addresses for each arrive at the same time one chip may activate in L \overline{BUSY} signal while another activates its R \overline{BUSY} signal. Both sides are now busy and the CPUs will wait indefinitely for their port to become free.

To overcome this "Busy Lock-Out" problem, Atmel has developed a MASTER/SLAVE system which uses a single hardware arbitrator located on the MASTER. The SLAVE has \overline{BUSY} inputs which allow direct interface to the MASTER with no external components, giving a speed advantage over other systems.

When dual-port RAMs are expanded in width, the SLAVE RAMs must be prevented from writing until after the \overline{BUSY} input has settled. Otherwise, the SLAVE chip may begin a write cycle during a conflict situation. Conversely, the write pulse must extend a hold time beyond \overline{BUSY} to ensure that a write cycle occurs once the conflict is resolved. This timing is inherent in all dual-port memory systems where more than one chip is active at the same time.

The write pulse to the SLAVE must be inhibited by the MASTER's maximum arbitration time. If a conflict then occurs, the write to the SLAVE will be inhibited because of the MASTER's BUSY signal.

Semaphore Logic

The M67025E is an extremely fast dual-port 4 Kb × 16 CMOS static RAM with an additional location dedicated to binary semaphore flags. These flags allow either of the processors on the left or right side of the dual-port RAM to claim priority over the other for functions defined by the system software. For example, the semaphore flag can be used by one processor to inhibit the other from accessing a portion of the dual-port RAM or any other shared resource.

The dual-port RAM has a fast access time, and the two ports are completely independent of each another. This means that the activity on the left port cannot slow the access time of the right port. The ports are identical in function to standard CMOS static RAMs and can be read from, or written to, at the same time with the only possible conflict arising from simultaneous writing to, or a simultaneous READ/WRITE operation on, a non-semaphore location. Semaphores are protected against such ambiguous situations and may be used by the system program to prevent conflicts in the non-semaphore segment of the dual-port RAM. The devices have an automatic power-down feature controlled by CS, the dual-port RAM select and SEM, the semaphore enable. The CS and SEM pins control on-chip-power-down circuitry that permits the port concerned to go into stand-by mode when not selected. This condition is shown in Table 1 where CS and SEM are both high.

Systems best able to exploit the M67025E are based around multiple processors or controllers and are typically very high-speed, software controlled or software-intensive systems. These systems can benefit from the performance enhancement offered by the M67025 hardware semaphores, which provide a lock-out mechanism without the need for complex programming.

Software handshaking between processors offers the maximum level of system flexibility by permitting shared resources to be allocated in varying configurations. The M67025E does not use its semaphore flags to control any resources through hardware, thus allowing the system designer total flexibility in system architecture.

An advantage of using semaphores rather than the more usual methods of hardware arbitration is that neither processor ever incurs wait states. This can prove to be a considerable advantage in very high speed systems.

How The Semaphore Flags Work

The semaphore logic is a set of eight latches independent of the dual-port RAM. These latches can be used to pass a flag or token, from one port to the other to indicate that a shared resource is in use. The semaphore provides the hardware context for the "Token Passing Allocation" method of use assignment. This method uses the state of a semaphore latch as a token indicating that a shared resource is in use. If the left processor needs to use a resource, it requests the token by setting the latch. The processor then verifies that the latch has been set by reading it. If the latch has been set the processor assumes control over the shared resource. If the latch has not been set, the left processor has established that the right processor had set the latch first, has the token and is using the shared resource. The left processor may then either repeatedly query the status of the semaphore, or abandon its request for the token and perform another operation whilst occasionally attempting to gain control of the token through a set and test operation. Once the right side has relinquished the token the left side will be able to take control of the shared resource.

The semaphore flags are active low. A token is requested by writing a zero to a semaphore latch, and is relinquished again when the same side writes a one to the latch.

The eight semaphore flags are located in a separate memory space from the dual-port RAM in the M67025E. The address space is accessed by placing a low input on the SEM pin (which acts as a chip select for the semaphore flags) and using the other control pins (address, OE and R/W) as nor-

mally used in accessing a standard static RAM. Each of the flags has a unique address accessed by either side through address pins A0-A2. None of the other address pins has any effect when accessing the semaphores. Only data pin D₀ is used when writing to a semaphore. If a low level is written to an unused semaphore location, the flag will be set to zero on that side and to one on the other side (see Table 5). The semaphore can now only be modified by the side showing the zero. Once a one is written to this location from the same side, the flag will be set to one for both sides (unless a request is pending from the other side) and the semaphore can then be written to by either side.

The effect the side writing a zero to a semaphore location has of locking out the other side is the reason for the use of semaphore logic in interprocessor communication. (A thorough discussion of the use of this feature follows below). A zero written to the semaphore location from the locked-out side will be stored in the semaphore request latch for that side until the semaphore is relinquished by the side having control. When a semaphore flag is read its value is distributed to all data bits so that a flag set at one reads as one in all data bits and a flag set at zero reads as all zeros. The read value is latched into the output register of one side when its semaphore select ($\overline{\text{SEM}}$) and output enable ($\overline{\text{OE}}$) signals go active. This prevents the semaphore changing state in the middle of a read cycle as a result of a write issued by the other side. Because of this latch, a repeated read of a semaphore flag in a test loop must cause either signal ($\overline{\text{SEM}}$ or $\overline{\text{OE}}$) to go inactive, otherwise the output will never change.

The semaphore must use a WRITE/READ sequence in order to ensure that no system level conflict will occur. A processor requests access to shared resources by attempting to write a zero to a semaphore location. If the semaphore is already in use, the semaphore request latch will contain a zero, yet the semaphore flag will appear as a one, and the processor will detect this status in the subsequent read (see Table 5). For example, assume a processor writes a zero to the left port at a free semaphore location. On a subsequent read, the processor will verify that it has written successfully to that location and will assume control over the resource concerned. If a processor on the right side then attempts to write a zero to the same semaphore flag it will fail, as will be verified by a subsequent read returning a one from the semaphore location on the right side has a READ/WRITE sequence been used instead, system conflict problems could have occurred during the interval between the read and write cycles.

It must be noted that a failed semaphore request needs to be followed by either repeated reads or by writing a one to the same location. The simple logic diagram for the semaphore flag in Figure 2 illustrates the reason for this quite clearly. Two semaphore request latches feed into a semaphore flag. The first latch to send a zero to the semaphore flag will force its side of the semaphore flag low and other side high. This status will be maintained until a one is written to the same semaphore request latch. Should a zero be written to the other side's semaphore request latch in the meantime, the semaphore flag will flip over to this second side as soon as a one is written to the first side's request latch. The second side's flag will now stay low until its semaphore request latch is changed to a one. Thus, clearly, if a semaphore flag is requested and the processor requesting it no longer requires access to the resource, the entire system can hang up until a one is written to the semaphore request latch concerned.

Semaphore timing becomes critical when both sides request the same token by attempting to write a zero to it at the same time. Semaphore logic is specially conceived to resolve this problem. The logic ensures that only one side will receive the token if simultaneous requests are made. The first side to make a request will receive the token where request do not arrive at the same time. Where they do arrive at the same time, the logic will assign the token arbitrarily to one of the ports. It should be noted, however, that semaphores alone do not guarantee that access to a resource is secure. As with any powerful programming technique, errors can be introduced if semaphores are misused or misinterpreted. Code integrity is of the utmost performance when semaphores are being used instead of slower, more restrictive hardware-intensive systems.

Semaphore initialization is not automatic and must therefore be incorporated in the power up initialization procedures. Since any semaphore flag containing a zero must be reset to one, initialization should write a one to all request flags from both sides to ensure that they will be available when required.

Using Semaphores – Some Examples

Perhaps the simplest application of semaphores is their use as resource markers for the M67025E's dual-port RAM. If it is necessary to split the 8 Kb × 16 RAM into two 4 Kb × 16 blocks which are to be dedicated to serving either the left or right port at any one time. Semaphore 0 can be used to indicate which side is controlling the lower segment of memory and semaphore 1 can be defined as indicating the upper segment of memory.

To take control of a resource, in this case the lower 4 Kb of a dual-port RAM, the left port processor would then write a zero into semaphore flag 0 and then read it back. If successful in taking the token (reading back a zero rather than a one), the left processor could then take control of the lower 4 Kb of RAM. If the right processor attempts to perform the same function to take control of the resource after the left processor has already done so, it will read back a one in response to the attempted write of a zero into semaphore 0. At this point the software may choose to attempt to gain control of the second 4 Kb segment of RAM by writing and then reading a zero in semaphore 1. If successful, it will lock out the left processor.

Once the left side has completed its task it will write a one to semaphore 0 and may then attempt to access semaphore 1. If semaphore 1 is still occupied by the right side, the left side may abandon its semaphore request and perform other operations until it is able to write and then read a zero in semaphore 1. If the right processor performs the same operation with semaphore 0, this protocol would then allow the two processes to swap 4 Kb blocks of dual-port RAM between one another.

The blocks do not have to be any particular size, and may even be of variable size depending on the complexity of the software using the semaphore flags. All eight semaphores could be used to divide the dual-port RAM or other shared resources into eight parts. Semaphores can even be assigned different meanings on each side, rather than having a common meaning as is described in the above example.

Semaphores are a useful form of arbitration in systems such as disk interfaces where the CPU must be locked out of a segment of memory during a data transfer operation, and the I/O device cannot tolerate any wait states. If semaphores are used, both the CPU and the I/O device can access assigned memory segments, without the need for wait states, once the two devices have determined which memory area is barred to the CPU.

Semaphores are also useful in applications where no memory WAIT state is available on one or both sides. On a semaphore handshake has been performed, both processors can access their assigned RAM segments at full speed.

Another application is in complex data structures. Block arbitration is very important in this case, since one processor may be responsible for building and updating a data structure whilst the other processor reads and interprets it. A major error condition may be created if the interpreting processor reads an incomplete data structure. Some sort of arbitration between the two different processors is therefore necessary. The building processor requests access to the block, locks it and is then able to enter the block to update the data structure. Once the update is completed the data structure may be released.

This allows the interpreting processor, to return to read the complete data structure, thus ensuring a consistent data structure.

Truth Table

Table 1. Non Contention Read/Write Control

Note: Inputs ⁽¹⁾						Outputs		Mode
$\overline{\text{CS}}$	$\overline{\text{R/W}}$	$\overline{\text{OE}}$	$\overline{\text{UB}}$	$\overline{\text{LB}}$	$\overline{\text{SEM}}$	$\text{IO}_8 - \text{IO}_{15}$	$\text{I/O}_0 - \text{I/O}_7$	
H	X	X	X	X	H	Hi-Z	Hi-Z	Deselected: Power Down
X	X	X	H	H	H	Hi-Z	Hi-Z	Deselected: Power Down
L	L	X	L	H	H	DATA_{IN}	Hi-Z	Write to Upper Byte Only
L	L	X	H	L	H	Hi-Z	DATA_{IN}	Write to Lower Byte Only
L	L	X	L	L	H	DATA_{IN}	DATA_{IN}	Write to Both Bytes
L	H	L	L	H	H	DATA_{OUT}	Hi-Z	Read Upper Byte Only
L	H	L	H	L	H	Hi-Z	DATA_{OUT}	Read Lower Byte Only
L	H	L	L	L	H	DATA_{OUT}	DATA_{OUT}	Read Both Bytes
X	X	H	X	X	X	Hi-Z	Hi-Z	Outputs Disabled
H	H	L	X	X	L	DATA_{OUT}	DATA_{OUT}	Read Data in Sema. Flag
X	H	L	H	H	L	DATA_{OUT}	DATA_{OUT}	Read Data in Sema. Flag
H		X	X	X	L	DATA_{IN}	DATA_{IN}	Write $\text{D}_{\text{IN}0}$ into Sema. Flag
X		X	H	H	L	DATA_{IN}	DATA_{IN}	Write $\text{D}_{\text{IN}0}$ into Sema. Flag
L	X	X	L	X	L	–	–	Not Allowed
L	X	X	X	L	L	–	–	Not Allowed

Note: 1. $\text{A}_{\text{OL}} - \text{A}_{12} \neq \text{A}_{\text{OR}} \cap \text{A}_{12\text{R}}$

Table 2. Arbitration Options

Options	Inputs					Outputs	
	$\overline{\text{CS}}$	$\overline{\text{UB}}$	$\overline{\text{LB}}$	$\overline{\text{M/S}}$	$\overline{\text{SEM}}$	$\overline{\text{BUSY}}$	$\overline{\text{INT}}$
Busy Logic Master	L	X	L	H	H	Output	–
	L	L	X	H	H	Signal	
Busy Logic Slave	L	X	L	L	H	Input	–
	L	L	X	L	H	Signal	–
Interrupt Logic	L	X	L	X	H	–	Output
	L	L	X	X	H		Signal
Semaphore Logic ⁽¹⁾	H	X	X	H	L	H	–
	H	X	X	L	L	Hi-Z	

Note: 1. Inputs Signals are for Semaphore Flags set and test (Write and Read) operations.

Table 3. Interrupt Flag^{(1) (4)}

Left Port					Right Port					Function
R/W _L	CS _L	OE _L	A _{0L} -A _{12L}	INT _L	R/W _R	CS _R	OE _R	A _{0R} -A _{12R}	INT _R	
L	L	X	1FFF	X	X	X	X	X	L ⁽²⁾	Set Right INT _R Flag
X	X	X	X	X	X	L	L	1FFF	H ⁽³⁾	Reset Right INT _R Flag
X	X	X	X	L ⁽³⁾	L	L	X	1FFE	X	Set Left INT _L Flag
X	L	L	1FFE	H ⁽²⁾	X	X	X	X	X	Reset Left INT _L Flag

- Notes: 1. Assumes $\overline{\text{BUSY}}_L = \overline{\text{BUSY}}_R = \text{H}$.
 2. If $\overline{\text{BUSY}}_L = \text{L}$, then NC.
 3. If $\overline{\text{BUSY}}_R = \text{L}$, then NC.
 4. H = HIGH, L = LOW, X = DON'T CARE, NC = NO CHANGE.

Table 4. Arbitration⁽²⁾

Left Port		Right Port		Flags ⁽¹⁾		Function
CS _L	A _{0L} - A _{12L}	CS _R	A _{0R} - A _{12R}	BUSY _L	BUSY _R	
H	X	H	X	H	H	No Contention
L	Any	H	X	H	H	No Contention
H	X	L	Any	H	H	No Contention
L	≠ A _{0R} - A _{12R}	L	≠ A _{0L} - A _{12L}	H	H	No Contention
Address Arbitration With CS Low Before Address Match						
L	LV5R	L	LV5R	H	L	L-Port Wins
L	RV5L	L	RV5L	L	H	R-Port Wins
L	Same	L	Same	H	L	Arbitration Resolved
L	Same	L	Same	L	H	Arbitration Resolved
CS Arbitration With Address Match Before CS						
LL5R	= A _{0R} - A _{12R}	LL5R	= A _{0L} - A _{12L}	H	L	L-Port Wins
RL5L	= A _{0R} - A _{12R}	RL5L	= A _{0L} - A _{12L}	L	H	R-Port Wins
LW5R	= A _{0R} - A _{12R}	LW5R	= A _{0L} - A _{12L}	H	L	Arbitration Resolved
LW5R	= A _{0R} - A _{12R}	LW5R	= A _{0L} - A _{12L}	L	H	Arbitration Resolved

- Notes: 1. INT Flags Don't Care.
 2. X = DON'T CARE, L = LOW, H = HIGH.
 LV5R = Left Address Valid ≥ 5 ns before right address.
 RV5L = Right Address Valid ≥ 5 ns before left address
 Same = Left and Right Addresses match within 5 ns of each other.
 LL5R = Left CS = LOW ≥ 5 ns before Right CS.
 RL5L = Right CS = LOW ≥ 5 ns before left CS.
 LW5R = Left and Right CS = LOW within 5 ns of each other.

Table 5. Example Semaphore Procurement Sequence

Function	D ₀ - D ₁₅ Left	D ₀ - D ₁₅ Right	Status
No Action	1	1	Semaphore free
Left Port Writes '0' to Semaphore	0	1	Left Port has semaphore token
Right Port Writes '0' to Semaphore	0	1	No change. Right side has no write access to semaphore
Left Port Writes '1' to Semaphore	1	0	Right port obtains semaphore token
Left Port Writes '0' to Semaphore	1	0	No change. Left port has no write access to semaphore
Right Port Writes '1' to Semaphore	0	1	Left port obtains semaphore token
Left Port Writes '1' to Semaphore	1	1	Semaphore free
Right Port Writes '0' to Semaphore	1	0	Right port has semaphore token
Right Port Writes '1' to Semaphore	1	1	Semaphore free
Left Port Writes '0' to Semaphore	0	1	Left Port has semaphore token
Left Port Writes '1' to Semaphore	1	1	Semaphore free

Note: 1. This table denotes a sequence of events for only one of the 8 semaphores on the M67025E.

Figure 1. Semaphore Logic

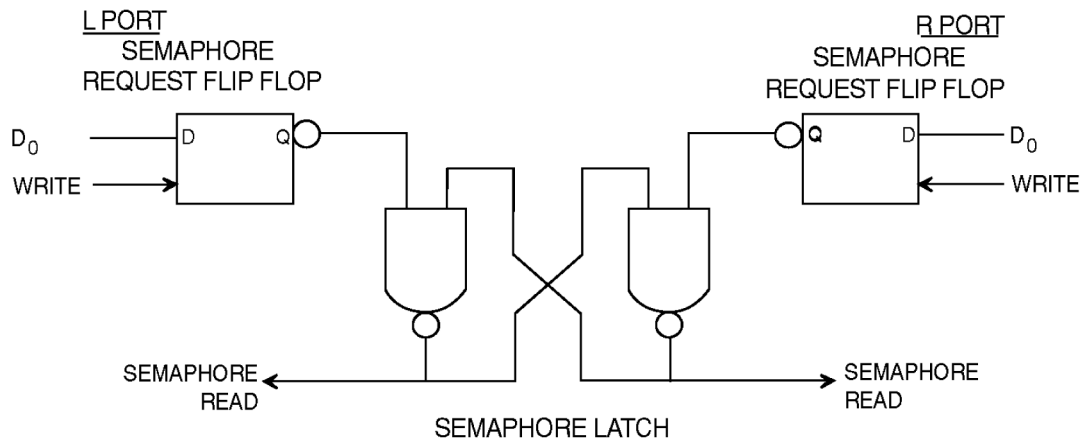

Electrical Characteristics

Absolute Maximum Ratings

Supply voltage (VCC-GND):..... -0.5V to 7.0V
 Input or output voltage applied: (GND - 0.5V) to (VCC + 0.5V)
 Storage temperature:..... -65°C to +150°C

*NOTE: Stresses greater than those listed under Absolute Maximum Ratings may cause permanent damage to the device. This is a stress rating only and functional operation of the device at these or any other conditions above those indicated in the operational sections of this specification is not implied. Exposure to absolute maximum rating conditions for extended periods may affect reliability.

DC Parameters

Table 6. DC Test Conditions

TA = -55°C to + 125°C; Vss = 0V; Vcc = 4.5V to 5.5V

Parameter	Description	67025-30	67025-45	Unit	Value
I _{CCSB} ⁽¹⁾	Standby supply current (Both ports TTL level inputs)	10	10	mA	Max
I _{CCSB1} ⁽²⁾	Standby supply current (Both ports CMOS level inputs)	500	500	µA	Max
I _{CCOP} ⁽³⁾	Operating supply current (Both ports active)	320	260	mA	Max
I _{CCOP1} ⁽⁴⁾	Operating supply current (One port active - One port standby)	200	180	mA	Max

- Notes: 1. $\overline{CS}_L = \overline{CS}_R \geq 2.2V$.
 2. $\overline{CS}_L = \overline{CS}_R \geq VCC - 0.2V$.
 3. Both ports active - Maximum frequency - Outputs open - $\overline{OE} = VIH$.
 4. One port active (f = fMAX) - Output open - One port stand-by TTL or CMOS Level Inputs - $\overline{CS}_L = \overline{CS}_R = VIH$

Parameter	Description	67025E	Unit	Value
IL I/O ⁽¹⁾	Input/Output leakage current	± 5	µA	Max
VIL ⁽²⁾	Input low voltage	0.8	V	Max
VIH ⁽²⁾	Input high voltage	2.2	V	Min.
VOL ⁽³⁾	Output low voltage (I/O ₀ - I/O ₁₅)	0.4	V	Max
VOH ⁽³⁾	Output high voltage	2.4	V	Min.
C IN	Input capacitance	5	pF	Max
C OUT	Output capacitance	7	pF	Max

1. Vcc = 5.5V, Vin = Gnd to Vcc, $\overline{CS} = VIH$, Vout = 0 to Vcc.
 2. VIH max = Vcc + 0.5V, VIL min = -0.5V or -1V pulse width 50 ns.
 3. Vcc Min., IOL = 4 mA, IOH = -4 mA.

Data-retention Mode

Atmel CMOS RAMs are designed with battery backup in mind. Data retention voltage and supply current are guaranteed over temperature. The following rules ensure data retention:

1. Chip select (\overline{CS}_L , \overline{CS}_R) must be held high during data retention; within V_{CC} to $V_{CC} - 0.2V$.
2. \overline{CS}_L , \overline{CS}_R must be kept between $V_{CC} - 0.2V$ and 70% of V_{CC} during the power up and power down transitions.
3. The RAM can begin operation $> t_{RC}$ after V_{CC} reaches the minimum operating voltage (4.5 volts).

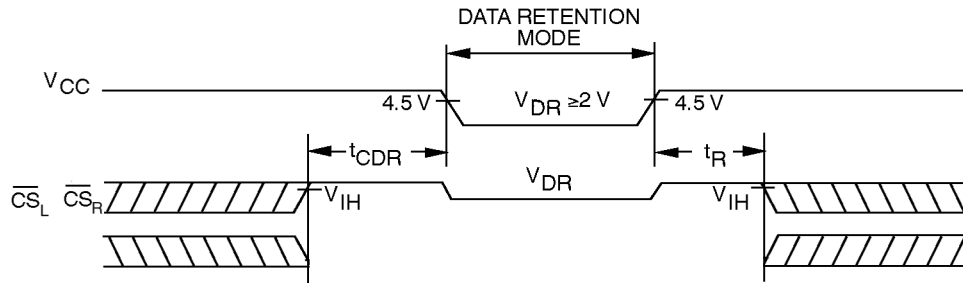

Timing

Parameter	Description	Minimum	Maximum	Unit
VDR	Data Retention Voltage	2.0	–	V
T_{CDR}	Chip deselect to data retention time	0	–	ns
T_R	Operation recovery time	$T_{AVAV}^{(1)}$	–	ns
ICCDR1 ⁽²⁾	Data retention current	–	400	μA

1. T_{AVAV} = Read cycle time.
2. $V_{IN}(\overline{CS}_{L/R}) = V_{CC}$
 $V_{CC} = 2V$
 $V_{IL} = 0V$
 $V_{IH} = V_{CC}$

AC Parameters

AC Test Conditions

Input Pulse Levels: GND to 3.0V

Input Rise/Fall Times: 5 ns

Input Timing Reference Levels: 1.5V

Output Reference Levels: 1.5V

Output Load: See Figures 2, 3

Figure 2. Output Load

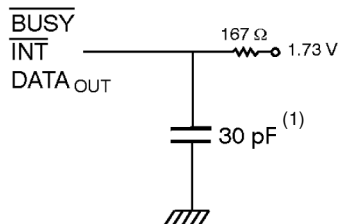
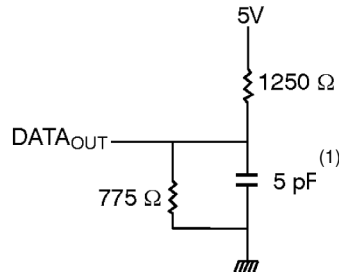

Figure 3. Output Load (for t_{HZ} , t_{LZ} , t_{WZ} , and t_{OW})



Note: 1. Including scope and jig.

AC Read Characteristics

Table 7. Over the Full Operating Temperature and Supply Voltage Range

Read Cycle		Parameter	M 67025-30		M 67025-45		Unit
Symbol ⁽⁴⁾	Symbol ⁽⁵⁾		Min.	Max.	Min.	Max.	
TAVAVR	t_{RC}	Read cycle time	30	–	45	–	ns
TAVQV	t_{AA}	Address access time	–	30	–	45	ns
TELQV	t_{ACS}	Chip Select access time ⁽³⁾	–	30	–	45	ns
TBLQV	t_{ABE}	Byte enable access time ⁽³⁾	–	30	–	45	ns
TGLQV	t_{AOE}	Output enable access time	–	15	–	25	ns
TAVQX	t_{OH}	Output hold from address change	3	–	3	–	ns
TELQX	t_{LZ}	Output low Z time ^{(1) (2)}	3	–	5	–	ns
TEHQZ	t_{HZ}	Output high Z time ^{(1) (2)}	–	15	–	20	ns
TPU	t_{PU}	Chip Select to power up time ⁽²⁾	0	–	0	–	ns
TPD	t_{PD}	Chip disable to power down time ⁽²⁾	–	50	–	50	ns
TSOP	t_{SOP}	SEM flag update pulse (OE or SEM)	15	–	15	–	ns
TSLQV	t_{ACS}	Semaphore Access time ⁽³⁾	–	30	–	45	ns

- Notes:
1. Transition is measured +500 mV from low or high impedance voltage with load (Figure 2 and Figure 3).
 2. This parameter is guaranteed but not tested.
 3. To access RAM CS = VIL, UB or LB = VIL, SEM = VIH. To access semaphore CS = VIH, SEM = VIL. Refer to Table 1.
 4. STD symbol.
 5. ALT symbol.

Timing Waveform of Read Cycle number 1, Either Side ⁽¹⁾₍₂₎⁽⁴⁾

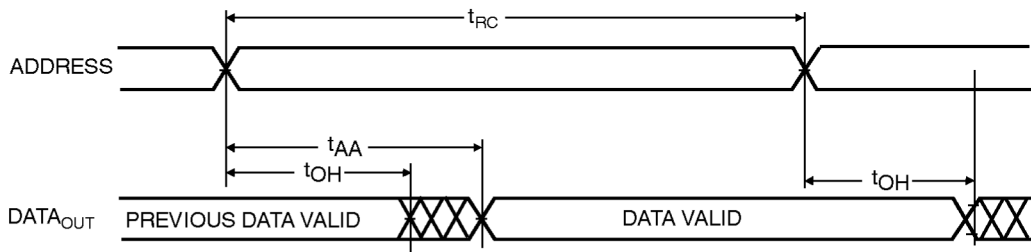

Timing Waveform of Read Cycle number 2, Either Side ⁽¹⁾₍₃₎⁽⁴⁾₍₅₎

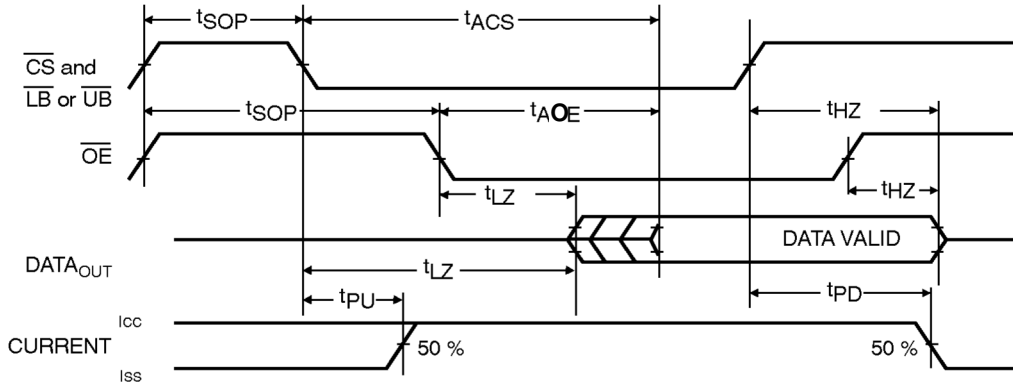

Timing Waveform of Read Cycle number 3, Either Side ⁽¹⁾₍₃₎⁽⁴⁾₍₅₎

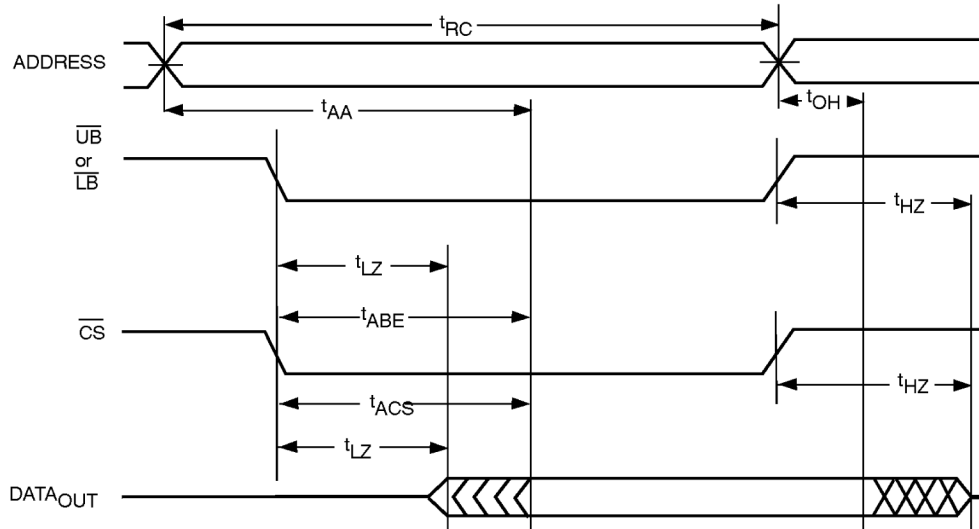

1. $\overline{R/\overline{W}}$ is high for read cycles.
2. Device is continuously enabled, $\overline{CS}=V_{IL}$, \overline{UB} or $\overline{LB}=V_{IL}$. This waveform cannot be used for semaphore reads.
3. Addresses valid prior to or coincident with \overline{CS} transition low.
4. $\overline{OE}=V_{IL}$
5. To access RAM, $\overline{CS}=V_{IL}$, \overline{UB} or $\overline{LB}=V_{IL}$, $\overline{SEM}=V_{IH}$. To access semaphore, $\overline{CS}=V_{IH}$, $\overline{SEM}=V_{IL}$. Refer to Table 1.

AC Write Characteristics

Table 8. AC Electrical Characteristics
Over the Full Operating Temperature and Supply Voltage Range

Write Cycle		Parameter	M 67025-30		M 67025-45		Unit
Symbol ⁽¹⁾	Symbol ⁽²⁾		Min.	Max.	Min.	Max.	
TAVAVW	t_{WC}	Write cycle time	30	–	45	–	ns
TELWH	t_{SW}	Chip select to end of write ⁽³⁾	25	–	40	–	ns
TAVWH	t_{AW}	Address valid to end of write	25	–	40	–	ns
TAVWL	t_{AS}	Address Set-up Time	0	–	0	–	ns
TWLWH	t_{WP}	Write Pulse Width	25	–	35	–	ns
TWHAX	t_{WR}	Write Recovery Time	0	–	0	–	ns
TDVWH	t_{DW}	Data Valid to end of write	20	–	25	–	ns
TGHQZ	t_{HZ}	Output high Z time ^{(4) (5)}	–	15	–	20	ns
TWHDX	t_{DH}	Data hold time ⁽⁶⁾	0	–	0	–	ns
TWLQZ	t_{WZ}	Write enable to output in high Z ^{(4) (5)}	–	15	–	20	ns
TWHQX	t_{OW}	Output active from end of write ^{(4) (5) (6)}	0	–	0	–	ns
TSWRD	t_{SWRD}	SEM flag write to read time	10	–	10	–	ns
TSPS	t_{SPS}	SEM flag contention window	10	–	10	–	ns

1. STD symbol.
2. ALT symbol.
3. To access RAM $\overline{CS} = V_{IL}$, \overline{UB} or $\overline{LB} = V_{IL}$, $\overline{SEM} = V_{IH}$. To access semaphore $\overline{CS} = V_{IH}$, $\overline{SEM} = V_{IL}$. This condition must be valid for entire t_{SW} time.
4. Transition is measured ± 500 mV from low or high impedance voltage with load (Figure 2 and Figure 3).
5. The parameters is guaranteed but not tested.
6. The specification for t_{DH} must be met by the device supplying write data to the RAM under all operating conditions. Although t_{DH} and t_{OW} values will vary over voltage and temperature, the actual t_{DH} will always be smaller than the actual t_{OW} .

Timing Waveform of Write Cycle number 1, R/W Controlled Timing^{(1) (3) (5) (8)}

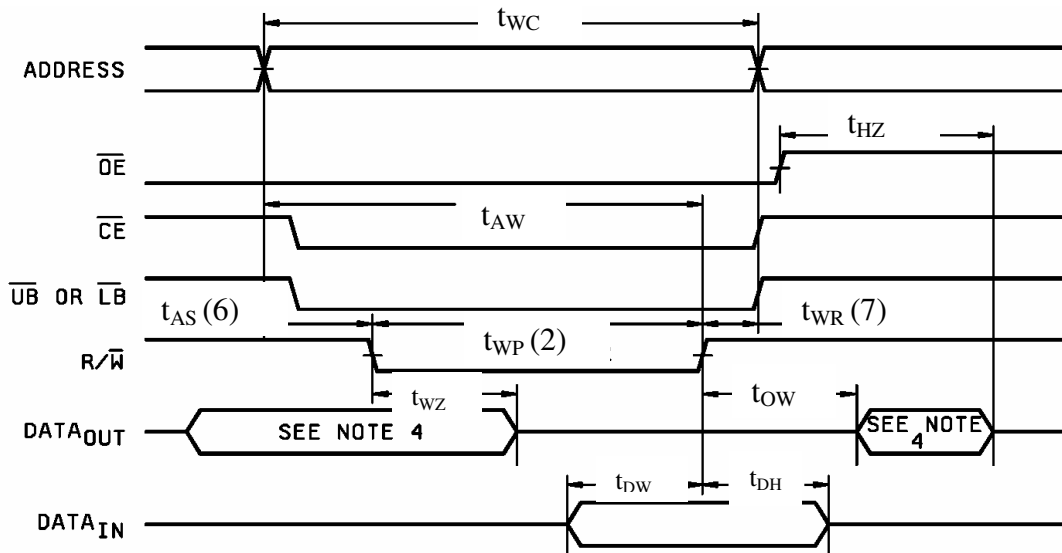

Timing Waveform of Write Cycle number 2, CS Controlled Timing^{(1) (3) (5) (8)}

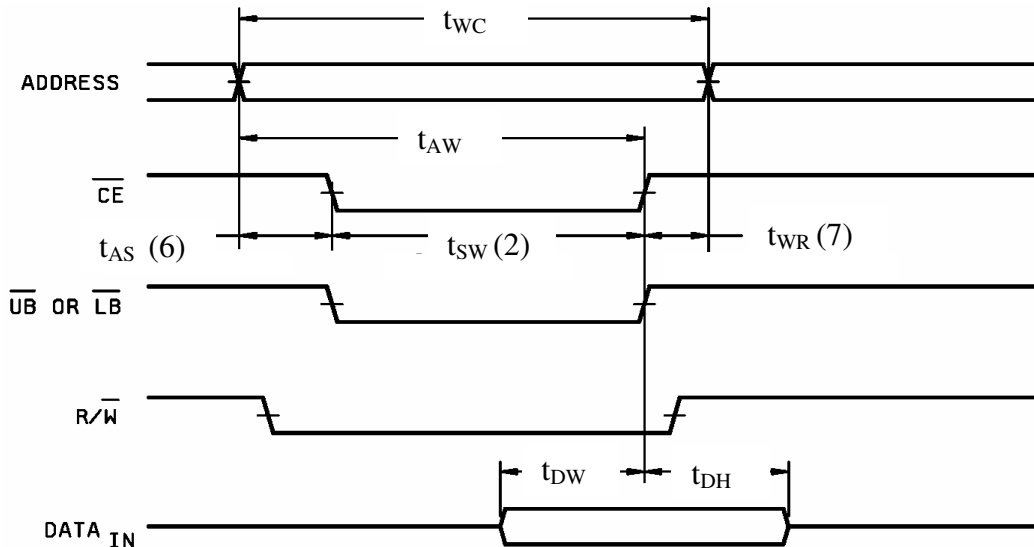

- Notes:
1. $\overline{R/\overline{W}}$ or \overline{CS} must be high during all address transitions.
 2. A write occurs during the overlap (t_{SW} or t_{WP}) of a low \overline{CS} or \overline{SEM} and a low $\overline{R/\overline{W}}$.
 3. t_{WR} is measured from the earlier of \overline{CS} or $\overline{R/\overline{W}}$ (or \overline{SEM} or $\overline{R/\overline{W}}$) going high to the end of write cycle.
 4. During this period, the I/O pins are in the output state, and input signals must not be applied.
 5. If the \overline{CS} or \overline{SEM} low transition occurs simultaneously with or after the $\overline{R/\overline{W}}$ low transition, the outputs remain in the high impedance state.
 6. Timing depends on which enable signal is asserted last.
 7. Timing depends on which enable signal is de-asserted first.
 8. If \overline{OE} is low during a $\overline{R/\overline{W}}$ controlled write cycle, the write pulse width must be the larger of t_{WP} or ($t_{WZ} + t_{DW}$) to allow the I/O drivers to turn off and data to be placed on the bus for the required t_{DW} . If \overline{OE} is high during a $\overline{R/\overline{W}}$ controlled write cycle, this requirement does not apply and the write pulse can be as short as the specified t_{WP} .

AC Busy Characteristics

Table 9. AC Electrical Characteristics
Over the Full Operating Temperature and Supply Voltage Range

Write Cycle	Parameter	M 67025-30		M 67025-45		Unit
		Min.	Max.	Min.	Max.	
Busy Timing (For Master 67025 only)						
t_{BAA}	\overline{BUSY} Access time from address matched	–	30	–	35	ns
t_{BDA}	\overline{BUSY} Disable time from address not matched	–	25	–	30	ns
t_{BAC}	\overline{BUSY} Access time to Chip Select	–	25	–	30	ns
t_{BDC}	\overline{BUSY} Disable time to Chip Select	–	20	–	25	ns
t_{WDD}	Write Pulse to data Delay ⁽¹⁾	–	55	–	70	ns
t_{DDD}	Write data valid to read data delay ⁽¹⁾	–	40	–	55	ns
t_{APS}	Arbitration priority set-up time ⁽²⁾	5	–	5	–	ns
t_{BDD}	\overline{BUSY} disable to valid data	–	⁽³⁾	–	⁽³⁾	ns
t_{WB}	Write to \overline{BUSY} input ⁽⁴⁾	0	–	0	–	ns
t_{WH}	Write hold after \overline{BUSY} ⁽⁵⁾	20	–	25	–	ns
t_{WDD}	Write pulse to data delay ⁽⁶⁾	–	55	–	70	ns
t_{DDD}	Write data valid to read data delay ⁽⁶⁾	–	40	–	55	ns

1. Port-to-port delay through RAM cells from writing port to reading port, refer to "Timing Waveform of Read with \overline{BUSY} (For Master 67025 only)'.
2. To ensure that the earlier of the two ports wins.
3. t_{BDD} is a calculated parameter and is the greater of 0, $t_{WDD} - t_{WP}$ (actual) to $t_{DDD} - t_{DW}$ (actual).
4. To ensure that the write cycle is inhibited during contention.
5. To ensure that a write cycle is completed after contention.
6. Port-to-port delay through RAM cells from writing port to reading port, refer to "Timing Waveforms of Read with Port-to-port delay (For Slave, 67025 only)'.

Timing Waveform of Read with $\overline{\text{BUSY}}$ (2) (3) (4) (For Master 67025)

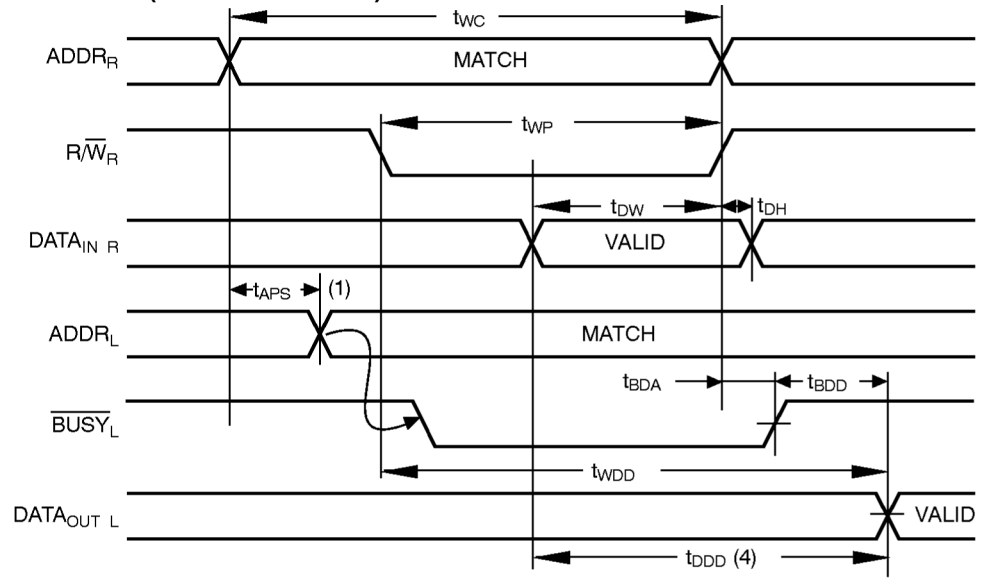

- Notes:
1. To ensure that the earlier of the two port wins.
 2. Write cycle parameters should be adhered to, to ensure proper writing.
 3. Device is continuously enabled for both ports.
 4. $\overline{\text{OE}} = \text{L}$ for the reading port.

Timing Waveform of Write with Port-to-Port (1) (2) (3) (For Slave 67025 Only)

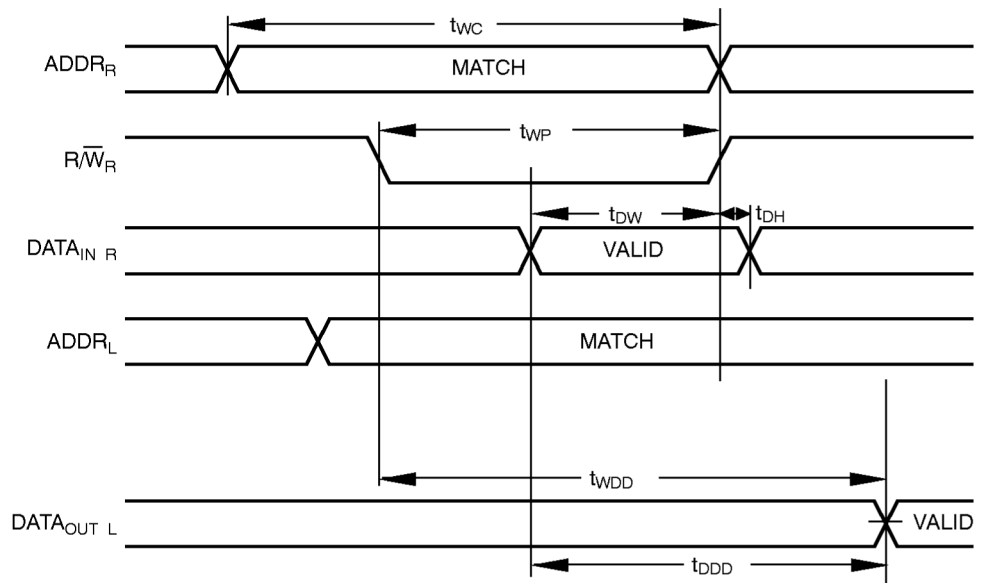

- Notes:
1. Assume $\overline{\text{BUSY}} = \text{H}$ for the writing port, and $\overline{\text{OE}} = \text{L}$ for the reading port.
 2. Write cycle parameters should be adhered to, to ensure proper writing.
 3. Device is continuously enabled for both ports.

Timing Waveform of Write with $\overline{\text{BUSY}}$ (For Slave 67025)



Timing Waveform of Contention Cycle number 1, CS Arbitration (For Master 67025 only)

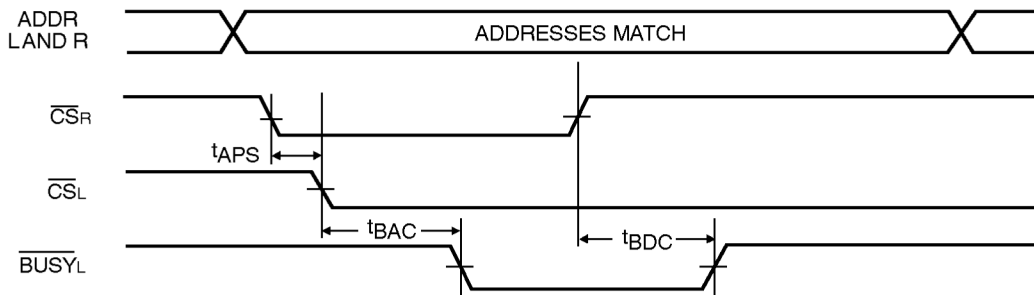
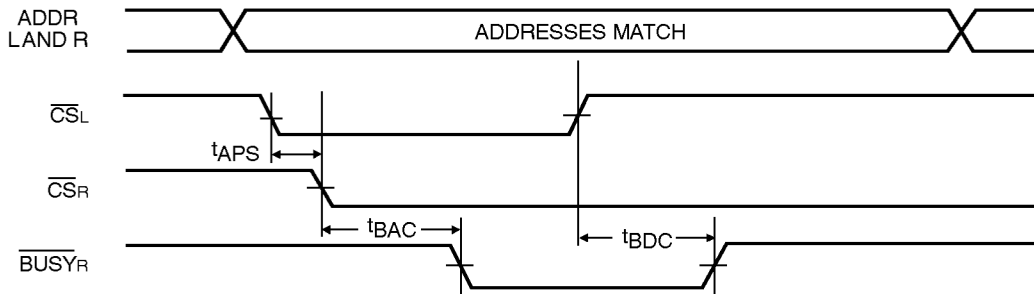

Timing Waveform of Contention Cycle number 2, Address Valid Arbitration (For Master 67025 only)⁽¹⁾

Left Address Valid First:

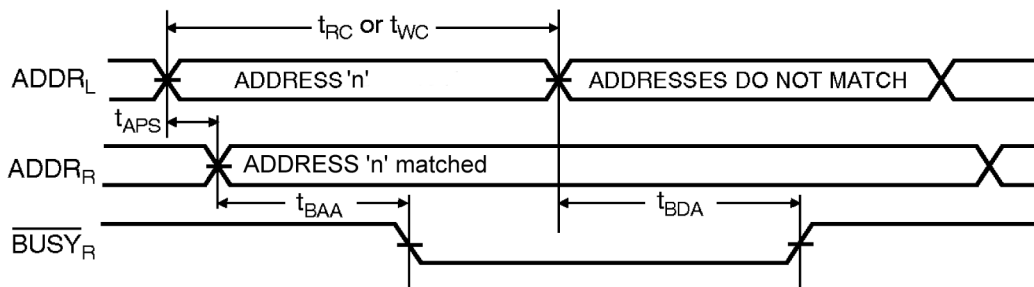

Right Address Valid First:

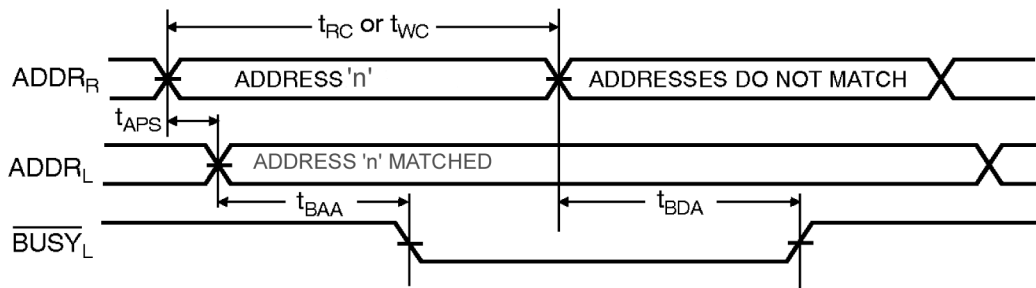

Note: 1. $\overline{CS}_L = \overline{CS}_R = V_{IL}$

AC Interrupt Characteristics

Interrupt Timing	Parameter	67025-30		67025-45		Unit
		Min.	Max.	Min.	Max.	
t_{AS}	Address set-up time	0	–	0	–	ns
t_{WR}	Write recovery time	0	–	0	–	ns
t_{INS}	Interrupt set time	–	25	–	35	ns
t_{INR}	Interrupt reset time	–	25	–	35	ns

Waveform of Interrupt Timing ⁽¹⁾

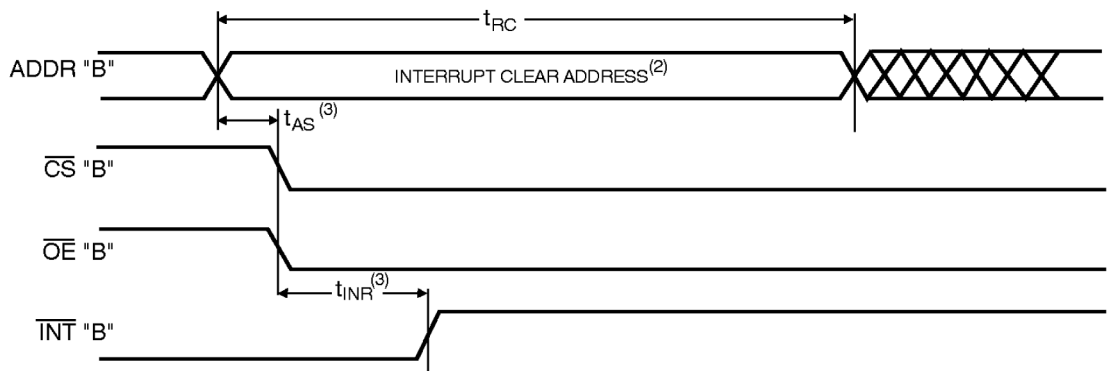
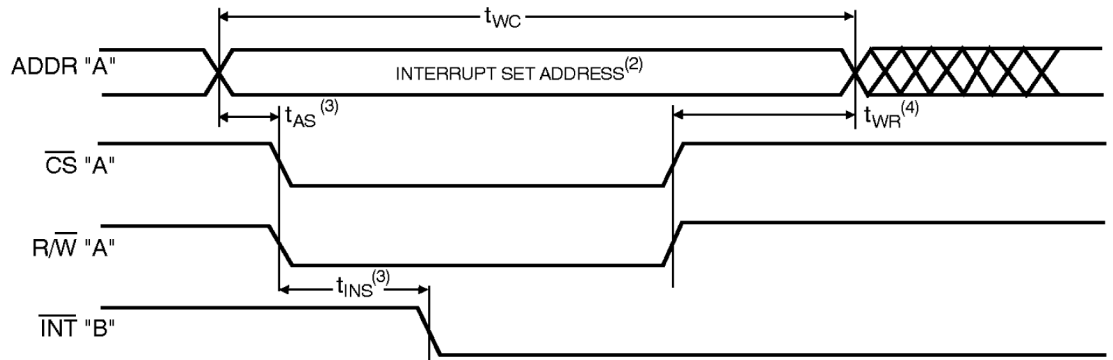

- Notes:
1. All timing is the same for left and right ports. Port 'A' may be either the left or right port. Port 'B' is the port opposite from 'A'.
 2. See interrupt truth table.
 3. Timing depends on which enable signal is asserted last.
 4. Timing depends on which enable signal is de-asserted first.

32-bit Master/Slave Dual-port Memory Systems

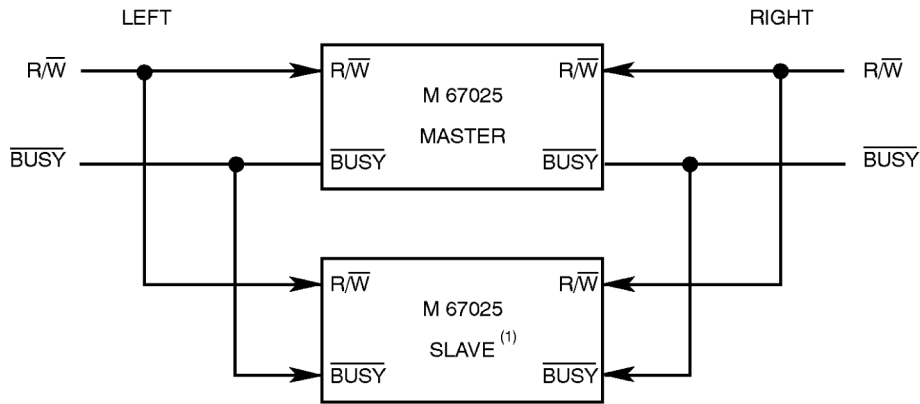

Note: 1. No arbitration in M67025E (SLAVE). $\overline{\text{BUSY-IN}}$ inhibits write in M67025E SLAVE.

Timing Waveform of Semaphore Read after Write Timing, Either Side⁽¹⁾

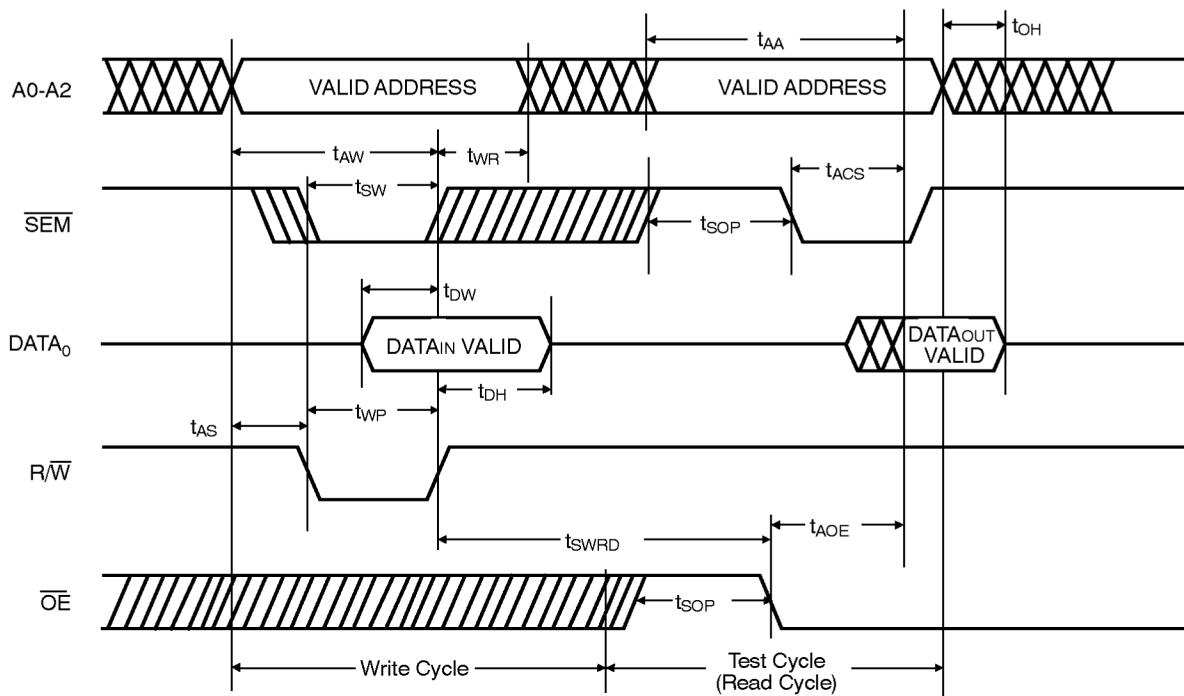

Note: 1. $\overline{\text{CS}} = V_{IH}$ for the duration of the above timing (both write and read cycle).

Timing Waveform of Semaphore Contention ^{(1) (3) (4)}

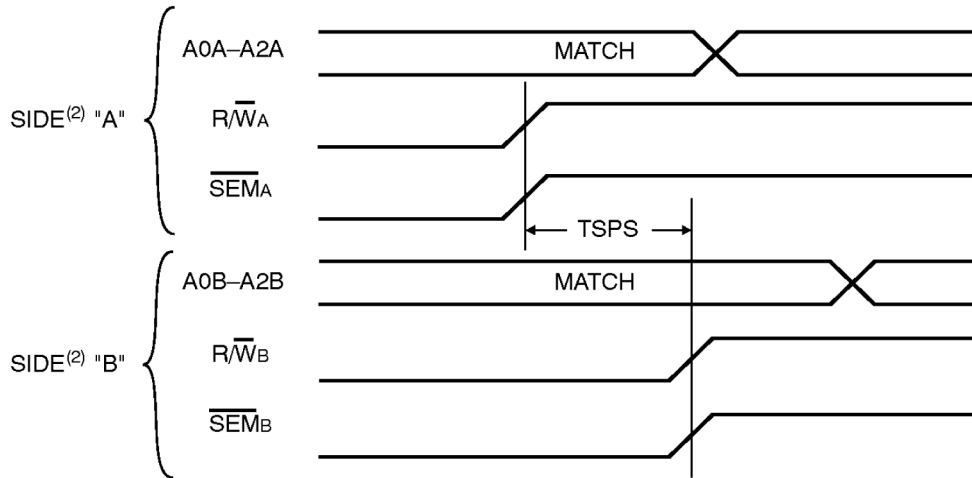

- Notes:
1. $D_{OR} = D_{OL}$, V_{IL} , $\overline{CS}_R = \overline{CS}_L = V_{IH}$, semaphore Flag is released from both sides (reads as ones from both sides) at cycle start.
 2. Either side 'A' = left and side 'B' = right, or side 'A' = right and side 'B' = left.
 3. This parameter is measured from the point where $\overline{R/W}_A$ or \overline{SEM}_A goes high until $\overline{R/W}_B$ or \overline{SEM}_B goes high.
 4. IF t_{SPS} is violated, the semaphore will fall positively to one side or the other, but there is no guarantee which side will obtain the flag.



Ordering Information

Part Number	Temperature Range	Speed	Package	Quality Flow
MMK2-67025EV-30-E	25°C	30 ns	MQFPF84	Engineering Samples
930105001	-55 to +125°C	30 ns	MQFPF84	ESCC
930105002	-55 to +125°C	45 ns	MQFPF84	ESCC
5962-9161709QZC	-55 to +125°C	30 ns	MQFPF84	QML Q
5962-9161706QZC	-55 to +125°C	45 ns	MQFPF84	QML Q
5962-9161709VZC	-55 to +125°C	30 ns	MQFPF84	QML V
5962-9161706VZC	-55 to +125°C	45 ns	MQFPF84	QML V
MM0-67025EV-30-E ⁽¹⁾	25°C	30 ns	Die	Engineering Samples
5962-9161709V9A ⁽¹⁾	-55 to +125°C	30 ns	Die	QML V

Note: 1. Contact Atmel for availability.

Package Drawings

84 lead MQFPF (1.15 inch square)

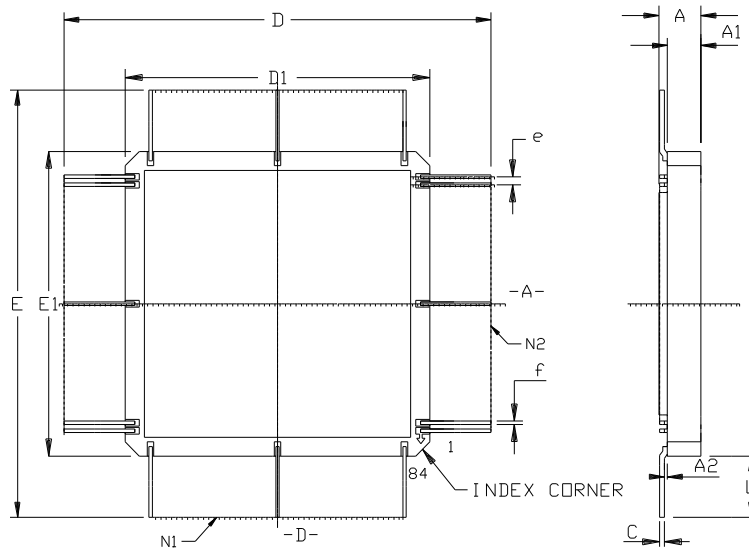

	mm		INCH	
	Min	Max	Min	Max
A	2.05	2.89	.081	.114
C	0.22	0.31	.009	.012
D	44.16	45.86	1.738	1.806
D1	28.96	29.46	1.140	1.160
E	44.16	45.86	1.738	1.806
E1	28.96	29.46	1.140	1.160
e	1.270 BSC		.050 BSC	
f	0.457 REF		.018 REF	
A1	1.82	2.67	.072	.105
A2	0.356 MAX		.014 MAX	
L	7.60	8.20	.299	.323
N1	21		21	
N2	21		21	



Document Revision History

- Rev. M -12/06**
1. Correction to timing diagrams, page 16.
 2. Add Write to upper byte only, in Table 1.

- Rev. N-04/07**
1. Update ordering information



Atmel Corporation

2325 Orchard Parkway
San Jose, CA 95131, USA
Tel: 1(408) 441-0311
Fax: 1(408) 487-2600

Regional Headquarters

Europe

Atmel Sarl
Route des Arsenalux 41
Case Postale 80
CH-1705 Fribourg
Switzerland
Tel: (41) 26-426-5555
Fax: (41) 26-426-5500

Asia

Room 1219
Chinachem Golden Plaza
77 Mody Road Tsimshatsui
East Kowloon
Hong Kong
Tel: (852) 2721-9778
Fax: (852) 2722-1369

Japan

9F, Tonetsu Shinkawa Bldg.
1-24-8 Shinkawa
Chuo-ku, Tokyo 104-0033
Japan
Tel: (81) 3-3523-3551
Fax: (81) 3-3523-7581

Atmel Operations

Memory

2325 Orchard Parkway
San Jose, CA 95131, USA
Tel: 1(408) 441-0311
Fax: 1(408) 436-4314

Microcontrollers

2325 Orchard Parkway
San Jose, CA 95131, USA
Tel: 1(408) 441-0311
Fax: 1(408) 436-4314

La Chantrerie
BP 70602
44306 Nantes Cedex 3, France
Tel: (33) 2-40-18-18-18
Fax: (33) 2-40-18-19-60

ASIC/ASSP/Smart Cards

Zone Industrielle
13106 Rousset Cedex, France
Tel: (33) 4-42-53-60-00
Fax: (33) 4-42-53-60-01

1150 East Cheyenne Mtn. Blvd.
Colorado Springs, CO 80906, USA
Tel: 1(719) 576-3300
Fax: 1(719) 540-1759

Scottish Enterprise Technology Park
Maxwell Building
East Kilbride G75 0QR, Scotland
Tel: (44) 1355-803-000
Fax: (44) 1355-242-743

RF/Automotive

Theresienstrasse 2
Postfach 3535
74025 Heilbronn, Germany
Tel: (49) 71-31-67-0
Fax: (49) 71-31-67-2340

1150 East Cheyenne Mtn. Blvd.
Colorado Springs, CO 80906, USA
Tel: 1(719) 576-3300
Fax: 1(719) 540-1759

Biometrics/Imaging/Hi-Rel MPU/ High Speed Converters/RF Datacom

Avenue de Rochepleine
BP 123
38521 Saint-Egreve Cedex, France
Tel: (33) 4-76-58-30-00
Fax: (33) 4-76-58-34-80

Literature Requests

www.atmel.com/literature

Disclaimer: The information in this document is provided in connection with Atmel products. No license, express or implied, by estoppel or otherwise, to any intellectual property right is granted by this document or in connection with the sale of Atmel products. **EXCEPT AS SET FORTH IN ATMEL'S TERMS AND CONDITIONS OF SALE LOCATED ON ATMEL'S WEB SITE, ATMEL ASSUMES NO LIABILITY WHATSOEVER AND DISCLAIMS ANY EXPRESS, IMPLIED OR STATUTORY WARRANTY RELATING TO ITS PRODUCTS INCLUDING, BUT NOT LIMITED TO, THE IMPLIED WARRANTY OF MERCHANTABILITY, FITNESS FOR A PARTICULAR PURPOSE, OR NON-INFRINGEMENT. IN NO EVENT SHALL ATMEL BE LIABLE FOR ANY DIRECT, INDIRECT, CONSEQUENTIAL, PUNITIVE, SPECIAL OR INCIDENTAL DAMAGES (INCLUDING, WITHOUT LIMITATION, DAMAGES FOR LOSS OF PROFITS, BUSINESS INTERRUPTION, OR LOSS OF INFORMATION) ARISING OUT OF THE USE OR INABILITY TO USE THIS DOCUMENT, EVEN IF ATMEL HAS BEEN ADVISED OF THE POSSIBILITY OF SUCH DAMAGES.** Atmel makes no representations or warranties with respect to the accuracy or completeness of the contents of this document and reserves the right to make changes to specifications and product descriptions at any time without notice. Atmel does not make any commitment to update the information contained herein. Unless specifically provided otherwise, Atmel products are not suitable for, and shall not be used in, automotive applications. Atmel's Atmel's products are not intended, authorized, or warranted for use as components in applications intended to support or sustain life.

©2007 Atmel Corporation. All rights reserved. Atmel®, logo and combinations thereof, and Everywhere You Are® are the trademarks or registered trademarks, of Atmel Corporation or its subsidiaries. Other terms and product names may be trademarks of others.



Printed on recycled paper.

4146N-AERO-04/07